



# **PNEUMATIC SPEED GOVERNORS**

**FOR FUEL INJECTION PUMPS**

**INSTRUCTION BOOK**



**ACTON, LONDON, W.3**

Telephone: SHEPHERDS BUSH 3111

Telegrams: VANTERIA, TELEX, LONDON

# PNEUMATIC GOVERNORS

The C.A.V. pneumatic governor has been designed to provide sensitive speed control within the entire operating range of an engine.

It is therefore suitable for commercial vehicle, marine and industrial engines and since it is a small compact unit it is particularly suitable for engines of small capacity where space is limited and weight saving is of primary importance.

The pressure in the induction pipe of a given engine is dependent on the velocity of the airflow through it; the higher the air velocity the lower will be the pressure. If a venturi is fitted in the induction pipe, local acceleration of the airflow will occur as the air passes through the venturi and an enhanced depression will be created which will be greatest at the smallest throat diameter. Since the velocity of the airflow is dependent on the quantity of air drawn into the engine, the depression in the venturi will vary according to the engine speed.

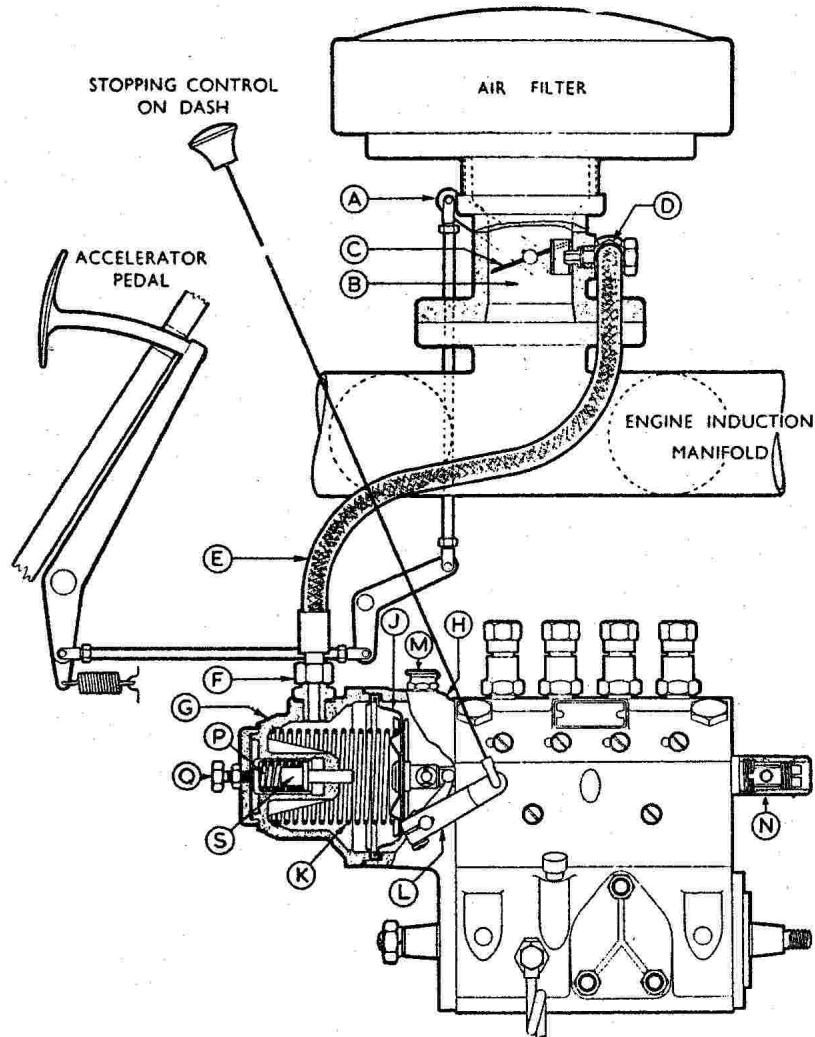

- |                                 |                                |
|---------------------------------|--------------------------------|
| A. Venturi valve control lever. | J. Diaphragm.                  |
| B. Venturi throat.              | K. Main diaphragm spring.      |
| C. Venturi butterfly valve.     | L. Stop lever.                 |
| D. Vacuum pipe union.           | M. Oil cap.                    |
| E. Vacuum pipe.                 | N. Control rod stop.           |
| F. Diaphragm housing union.     | P. Auxiliary idling spring.    |
| G. Diaphragm housing.           | Q. Auxiliary idling set-screw. |
| H. Main housing.                | S. Auxiliary idling plunger.   |

Fig. 1—Diagrammatic and sectional views of the pneumatic governor with single pitot venturi flow control unit.

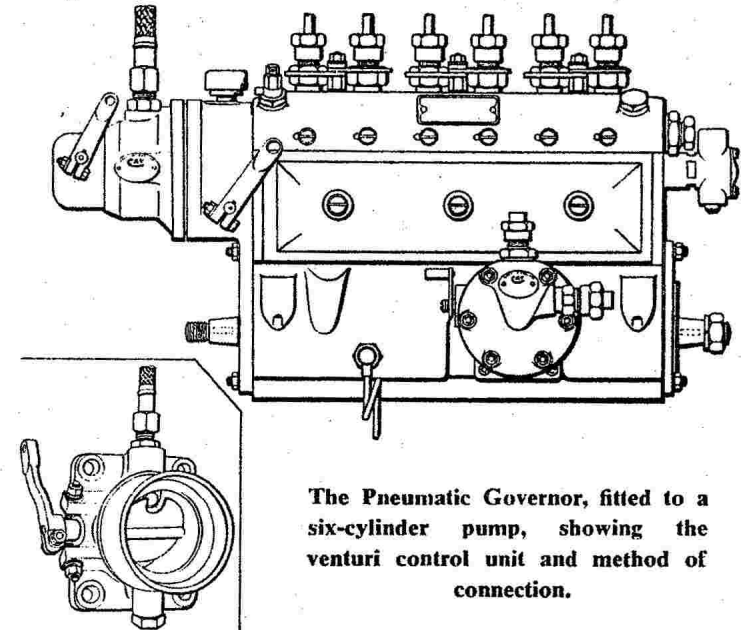

The Pneumatic Governor, fitted to a six-cylinder pump, showing the venturi control unit and method of connection.

A depression created in this way is used by the pneumatic governor to operate a diaphragm which is connected to the control rod of the fuel injection pump.

Changes in the value of the depression resulting from fluctuations of engine speed cause movement of the diaphragm and control rod. Compensating changes in the output of the fuel injection pump, which occur when the control rod is moved, maintain a selected engine speed within close limits.

## CONSTRUCTIONAL DETAILS

The C.A.V. pneumatic governor consists of a venturi flow control unit located between the induction pipe on the engine and the air filter, and a diaphragm unit mounted directly on the fuel injection pump.

Referring to Fig. 1 it will be seen that the body of the venturi unit is flanged at one end so that it can be secured to the induction pipe on the engine, and is spigoted at the other end to accommodate the air filter. The diameter of the throat will vary according to the capacity of the engine to which it is fitted.

Airflow through the throat of the venturi is regulated by a butterfly valve (C) which is mounted on a spindle carried in bushes pressed into the venturi body. The control lever (A) is secured to the butterfly valve spindle and is connected by suitable control linkage to the accelerator pedal. Maximum speed and idling stops (T and U Fig. 2) provide means of adjusting the limits of movement of the butterfly valve.

A small auxiliary venturi situated within the main venturi may be secured to, or cast integrally with the body of the venturi unit. Projecting into the auxiliary venturi at right angles to the airflow is a pitot tube which is connected to the diaphragm unit by the flexible pipe (E). Double pitot venturi flow control units incorporate a second auxiliary venturi and pitot tube (see Fig. 3). This pitot tube is connected by a flexible pipe to an air valve situated in the diaphragm unity.

The flexible leather diaphragm (J. Fig. 1) is clamped between the governor housing (H) and the governor cover (G). It is connected

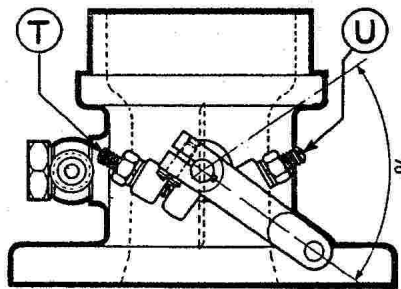

T—Adjustable screw for maximum speed.

U—Adjustable screw for idling.

Fig. 2—Control stops on venturi.

to the control rod of the fuel injection pump and is spring loaded by the governor spring (K). Pressure exerted on the diaphragm by the spring tends to move the diaphragm and control rod towards the maximum fuel stop (N).

Control rod movement is limited by adjustable stops. Auxiliary idling stops of the types shown in Figs. 1 and 4 may be fitted to

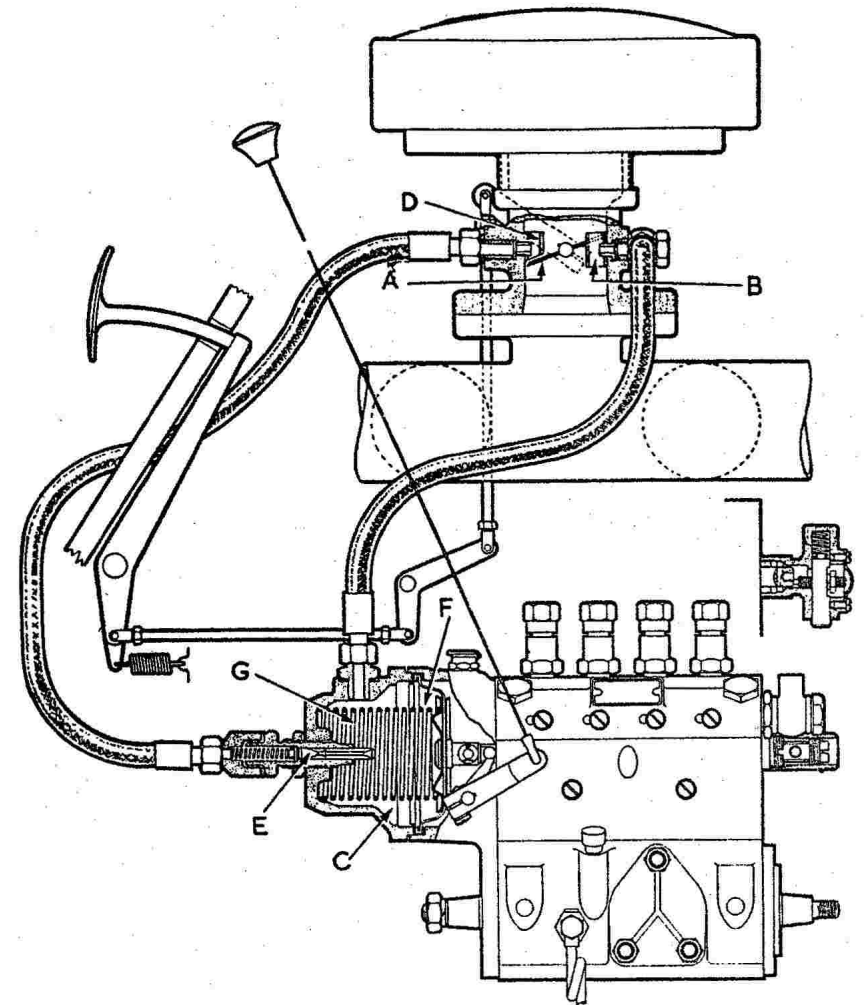

A. Butterfly valve.

B. Auxiliary venturi.

C. Diaphragm chamber.

D. Secondary auxiliary venturi

E. Air valve.

F. Diaphragm.

G. Governor spring.

Fig. 3—Diagrammatic and sectional views of the pneumatic governor with double pitot venturi flow control unit.

governors with single pitot venturi units. That illustrated in Fig. 1 consists of a plunger (S) which is spring loaded by the spring (P). The adjusting screw (Q) permits adjustment of the spring pressure acting on the plunger.

The cam operated auxiliary idling stop (Fig. 4) is recommended for use when difficulty is experienced in obtaining even running at idling, without exceeding the maximum idling speed or the maximum no load overrun. The cam (V) is rotated by movement of the control lever (W) which is connected by suitable control linkage to the accelerator pedal. The linkage is so arranged that the spring (P) is compressed when the accelerator pedal is released.

When double pitot venturi units are fitted, the auxiliary idling stop is replaced by a spring loaded air valve (E. Fig. 3). When the diaphragm moves beyond the normal idling position this valve is opened to permit relief of the depression in the diaphragm chamber.

Maximum fuel stops are normally fitted at the end of the pump housing remote from the governor. They provide means of adjusting the maximum fuelling and may be sealed after setting, to prevent unauthorized adjustment. Two types of stop are illustrated in Figs. 5 and 5a.

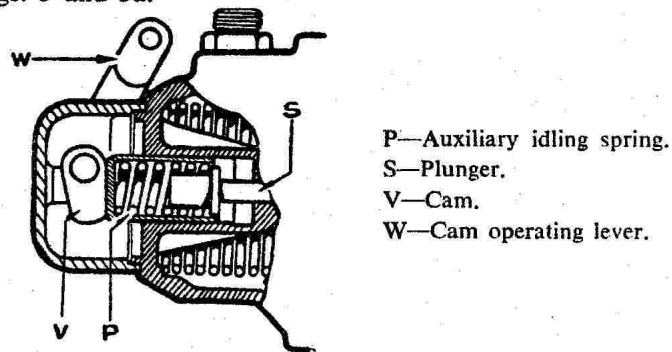

Fig. 4—Cam-operated idling spring

The lever (L. Fig. 1) is connected to the "stop" control in the driving cab. It is spring loaded, and remains inoperative when the engine is running. When the "stop" control is operated, the control rod is moved to the "no fuel" position.

An excess fuel device of the type illustrated in Fig. 6 may be fitted to permit overriding of the maximum fuel stop to provide excess fuel for starting. The maximum fuel stop (2) is carried on a spring loaded plunger (1). When the control rod is in the normal maximum fuel position the end of the control rod bears against the stop screw. Depression of the plunger (1) brings the stop screw into alignment with a hole drilled in the end of the control rod, and thus permits the control rod to move beyond the normal maximum fuel position. When the engine has started and the accelerator pedal has been released, the control rod moves towards the idling stop and the

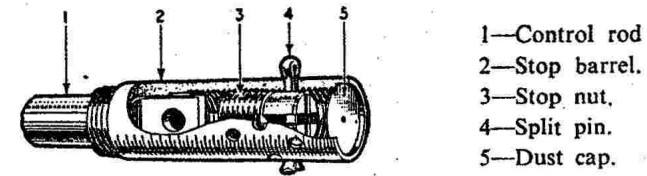

Fig. 5—Control rod stop.

plunger (1) and the maximum fuel stop (2) are returned automatically to the normal working position by the spring (3).

A combined excess fuel device and "shut off" control incorporated in some pneumatic governors, is illustrated in Figs. 7 and 7a.

The shaft is rotated to operate the fuel "shut off" mechanism, and moved axially when excess fuel is required to facilitate starting. After either operation the shaft (6) is returned to its normal operating position by the spring (1) which functions as a torsion spring when the shaft is turned, and as a compression spring when the shaft is moved axially.

The pawl (3) is secured to the shaft (6) and is held in contact with the adjusting screw (2) by torsional pressure exerted on the shaft by the spring (1). The edge of the pawl acts as a maximum fuel stop, which is adjusted by movement of the adjusting screw (2). A special guide block (5), which couples the control rod to the governor diaphragm butts against the pawl when the control rod is in the maximum fuel position. While the engine is stationary the control rod is held in the maximum fuel position by the governor spring (7). Axial movement of the shaft (6) aligns the pawl with a slot machined in the guide block, and the control rod then moves beyond the maximum fuel position to provide excess fuel to facilitate starting (see Fig 7a). After the engine has started, the governor moves the control rod towards the idling position. The guide block is then disengaged from the pawl, and the shaft (C) and pawl are returned by the spring (1) to their normal operating position, illustrated in Fig. 7.

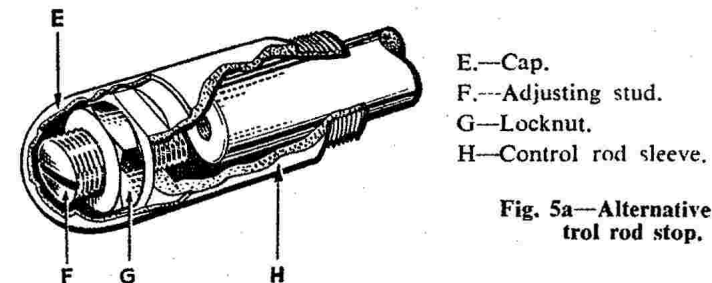

Fig. 5a—Alternative control rod stop.

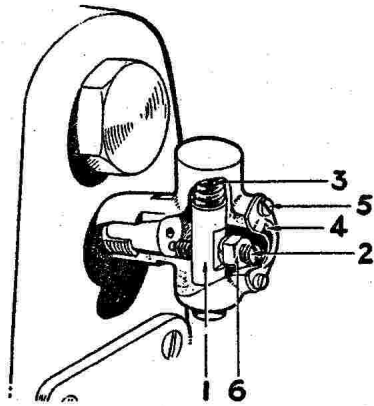

Fig. 6—Excess fuel device.

When the shaft is rotated for “shut off”, (as indicated by the arrow in Fig. 7) the pawl exerts pressure on the face of the guide block and moves the control rod to the “no fuel” position.

A baulking device can be incorporated in this type of control in order to prevent overriding of the maximum fuel stop during normal engine running by locking the control in the excess fuel position (see Figs. 8 and 8a).

A spring loaded latch (2) is mounted on a pivot secured to the face of the guide block (1). When the control is in the normal running position with the engine stationary, the control rod is in the maximum fuel position, and the face of the guide block is in contact with the edge of the pawl (3). The latch is held by spring pressure against a limiting stop, and covers the slot in the guide block. There is a small clearance between the edge of the latch and the cheek of the pawl.

When the control is moved to the excess fuel position the cheek of the pawl (3) contacts the edge of the latch, and the latch is moved away from the guide block slot to permit the control rod to move to the excess fuel position. The latch is then held in contact with the cheek of the pawl by the latch spring, Fig. 8.

After the engine has started, the control rod moves towards the idling position. The guide block is disengaged from the pawl, and the shaft (5) returns to the normal running position under influence of the spring (4). The spring loaded latch (2) then moves to its position covering the slot in the guide block. Depression of the accelerator will cause the control rod to move to the maximum fuel position, which is reached when the face of the guide block contacts the edge of the pawl (see Fig. 8a).

Should the excess fuel control be retained in the excess fuel position, the guide block slot and the pawl will remain in alignment, but since the slot is covered by the latch (2) the control rod will reach its limit of movement when the cheek of the latch contacts the edge of the

pawl (3). control rod movement is therefore reduced by an amount equal to the thickness of the latch. The resulting decreased maximum fuel delivery cannot be exceeded until the excess fuel control is released, and excess fuel for future starting will not be obtained unless the control is first returned to the normal running position.

## OPERATION

### Governors fitted with Single Pitot venturi flow control units (Fig. 1)

The pressure within the induction pipe of a given engine varies according to the velocity of the airflow through it; the higher the air velocity the lower will be the pressure. Since the air velocity is dependent on the quantity of air drawn into the engine, the pressure in the induction pipe will vary according to the engine speed.

When the venturi control unit is fitted a local acceleration of the airflow occurs as the air passes through the venturi and a depression is created which is greatest at the smallest throat diameter. The depression so created varies according to the engine speed since the venturi unit is mounted on the induction pipe of the engine.

A pitot tube which projects into an auxiliary venturi situated at the smallest throat diameter of the main venturi is connected to the flexible pipe (E). The depression existing in the main venturi is transmitted through the pitot tube and the flexible pipe to an airtight chamber in the diaphragm unit. It acts upon the flexible diaphragm (J) which is connected to the control rod of the fuel injection pump.

The governor spring (K) exerts pressure on the diaphragm in opposition to the force exerted by the depression and in consequence the diaphragm will assume a position where the two forces acting upon it are in equilibrium. It follows, therefore, that any change in the value of the depression will cause the diaphragm to move, and since the diaphragm is connected to the control rod of the fuel injection pump a change of fuelling will occur.

Force exerted on the diaphragm by the depression tends to move the control rod towards the auxiliary idling stop, while that exerted by the governor spring tends to move the control rod towards the maximum fuel stop (N). When the engine is running at a fixed throttle setting the control rod assumes a position where the forces acting on the diaphragm are in equilibrium. Fluctuations of engine speed resulting from changes of engine loading will result in corresponding changes of the depression. An increase of the depression which occurs when the engine exceeds the selected speed will cause the control rod to move towards the auxiliary idling stop. The output of the fuel injection pump will then be reduced and engine speed will fall until the selected engine speed is restored. Similarly, a fall in engine speed resulting from increased engine loading will cause the control rod to move towards the maximum fuel stop under influence of the spring (K), thus increasing the output of the fuel injection pump and increasing the engine speed until the selected running speed has been regained.

Any selected engine speed will therefore be maintained within close limits, since any speed change is accompanied by a compensating change in the output of the fuel injection pump.

When the engine is stationary, the control rod is held against the maximum fuel stop by the force exerted on the diaphragm by the governor spring. Although the control rod is in the correct position for starting the engine, the accelerator pedal is usually depressed during this operation. After the engine has started, it may be idled by releasing the accelerator and thus closing the butterfly valve in the flow control unit. Restriction of the main venturi will cause an immediate increase in the velocity of the airflow and the resulting increase of the depression will move the control rod to the idling position. Speed control is maintained at idling in the same manner as at intermediate throttle settings. Violent movement of the control rod is prevented however, by the spring loaded auxiliary idling stop. An increased depression caused by any increase in engine speed will move the diaphragm against the stop and overcome the pressure exerted on the plunger by the spring (P).

#### Governors fitted with double pitot venturi units (Fig. 3).

Governor operation is basically unchanged, movement of the diaphragm and control rod being governed by the velocity of the airflow through the auxiliary venturi (B).

A pitot tube projecting into the second auxiliary venturi (D) is connected by a flexible pipe to an air valve (E) which is fitted in place of an auxiliary idling stop. The butterfly valve is not cut away to permit passage of air through the auxiliary venturi (D) when the valve is closed, so that at idling speeds there is no airflow through the second auxiliary venturi and the air valve (E) opens to atmospheric pressure. When the butterfly valve is open the velocity of the airflow through each auxiliary venturi is the same, and the air valve (E) opens to a depression equal to that in the diaphragm chamber (C).

When the engine is idling, the metal centre of the diaphragm is in contact with the air valve (E). An increase in engine speed will cause an increase of the depression in the diaphragm chamber (C) and the diaphragm and control rod will move towards the "no fuel" position. Movement in this direction beyond the normal idling position will reduce the output of the fuel injection pump and at the same time open the air valve (E). Since the air valve opens to atmospheric pressure when the butterfly valve is closed, the depression in the diaphragm chamber (C) will be relieved and the diaphragm and control rod will move towards the maximum fuel position. This movement will be arrested, however, when the diaphragm reaches the normal idling position, at which point the air valve will be closed and the depression in the diaphragm chamber restored. This interference with normal governor action serves to prevent violent movement of the control rod at idling speeds, but does not interfere at high speeds when the velocity of the airflow through each auxiliary venturi is equal.

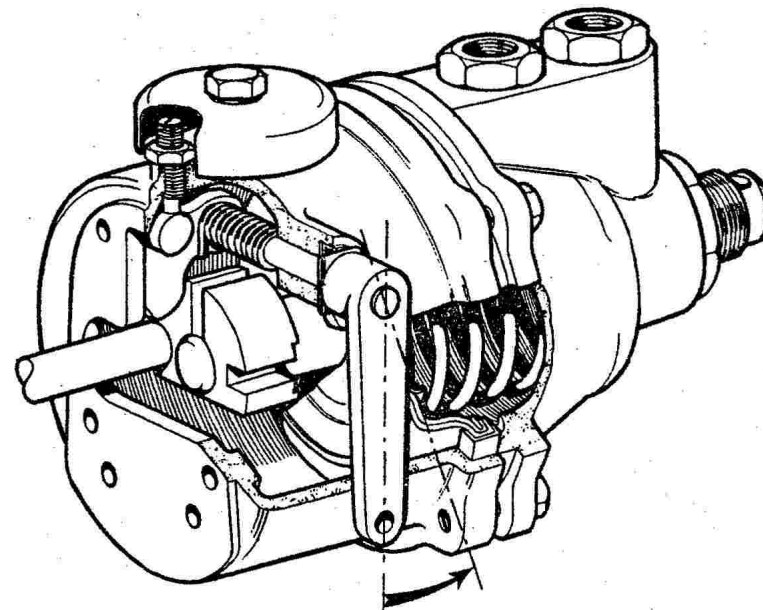

Fig. 7—Control in normal maximum fuel position.

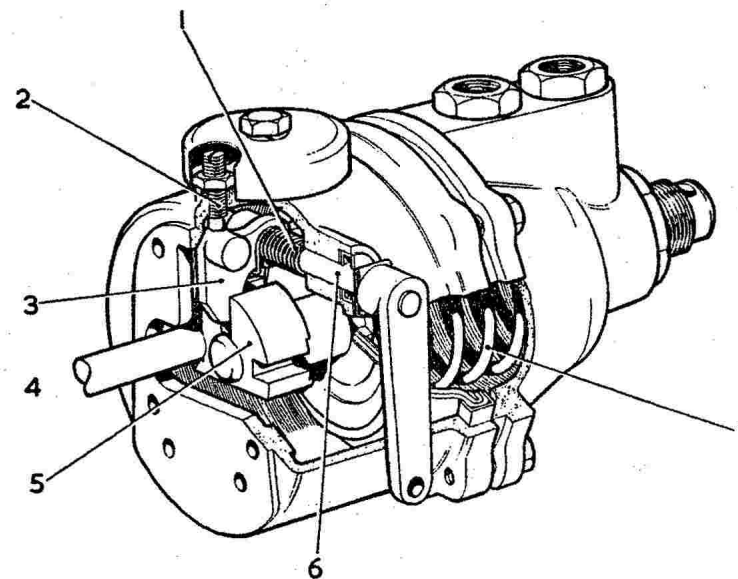

Fig. 7a—Control in excess fuel position.

## FITTING

Care must be taken to ensure that there are no air leaks in the induction system of the engine, or at any of the pipe unions or jointing faces in the diaphragm and venturi flow control units. Leakage of air can impair the efficiency of the governor and in extreme cases can render it inoperative. The control rod will be held in the maximum fuel position if no depression is transmitted to the diaphragm chamber and serious damage to the engine will result from excessive engine speed if the "shut off" control is not operated immediately.

The butterfly valve must have the complete range of movement between the maximum speed and idling stops (T and U. Fig. 2) when the accelerator pedal is operated. Pedal stops should be adjusted so that the load applied to the pedal is not transmitted to the butterfly valve stops. When adjustments are made to the idling or maximum fuel stops a compensating adjustment must be made to the pedal stops.

The lever (L. Fig. 1) is connected by a cable or other suitable linkage to the "stop" control in the driving cab. The control must be conveniently situated and perfectly free in operation, so that the engine can be stopped immediately in an emergency.

When a cam operated auxiliary idling stop is fitted, the linkage connecting the lever (V. Fig. 4) to the accelerator pedal must be adjusted so that the spring is compressed when the pedal is released.

## ADJUSTMENT

### Maximum Fuel

The maximum fuel stop (N. Fig 1) is normally adjusted by the engine manufacturer until the required engine performance is obtained and then sealed to prevent unauthorised adjustment. Any adjustment that may be deemed necessary during service is effected in the following manner :—

1. Remove the dust cap (5. Fig. 5).
2. Remove the split pin (4).
3. Screw the stop (3) outwards to increase the maximum fuel setting and inwards to reduce it.
4. After adjustment has been made, replace the split pin and the dust cap.

The maximum fuel stop shown in Fig. 5a is fitted to dust-proofed pumps.

Adjustment is made in the following manner :—

1. Remove the dust cap (E).
2. Slacken the locknut (G).
3. Screw the stop (F) outwards to increase the maximum fuel setting and inwards to decrease it.
4. Tighten the locknut after the setting has been made and refit the dust cap.

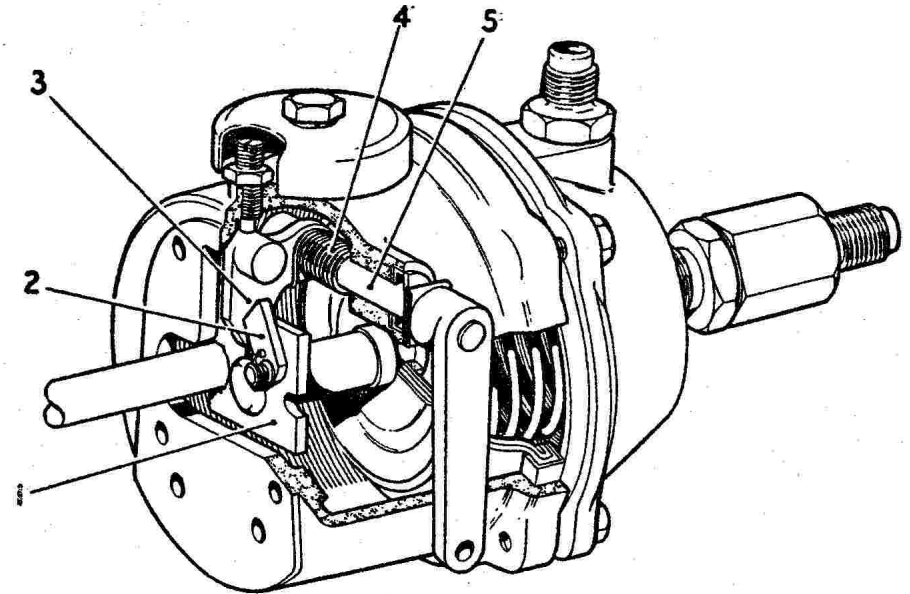

Fig. 8—Control in excess fuel position.

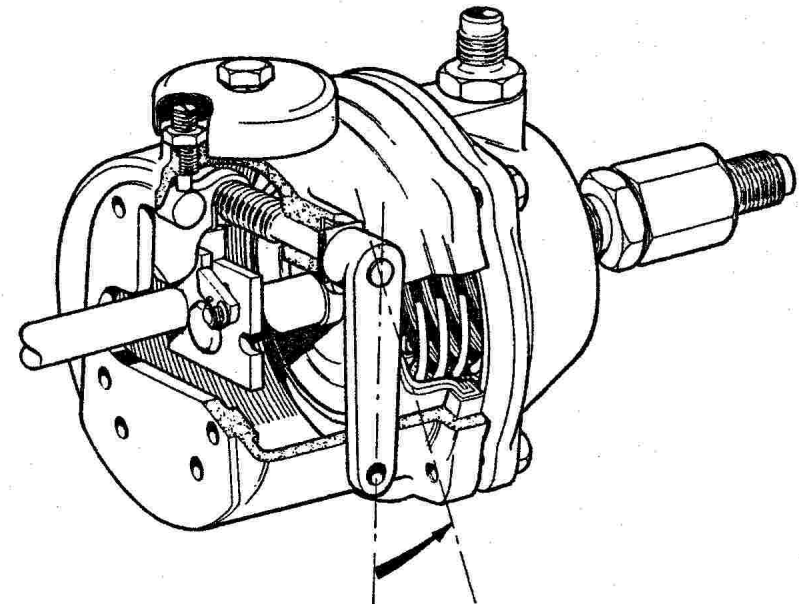

Fig. 8a—Control in normal maximum fuel position.

Alteration of the setting of the maximum fuel stop will change the power output of the engine and the fuel consumption. Excessive increase of maximum fuelling will result in smoky exhaust and increased fuel consumption. When adjustment is made a compromise should be sought between power output, exhaust colour, and fuel consumption.

When an excess fuel device of the type illustrated in Fig. 6 is fitted the maximum fuel stop is carried on the spring loaded plunger (1). Before adjustment can be made, the screws (5) and the cover (4) must be removed. The locknut (6) can then be slackened, and the stop screw (2) adjusted in the required direction. It is screwed outwards to increase the maximum fuel setting.

When the combined excess fuel device and "stop" control is fitted (Fig. 7a), alteration of the maximum fuel setting is made by adjustment of the stop screw (2) after the breather has been removed.

#### **Maximum Speed**

Absolute maximum speed is governed by the throat diameter of the venturi. The maximum speed of the engine can be adjusted to speeds below this figure by limiting the movement of the butterfly valve in the venturi control unit. Adjustment is made by movement of the stop screw (T. Fig. 2).

#### **Idling Speed**

When single pitot venturi units are fitted the idling speed is adjusted by movement of the idling stop (U. Fig. 2). Adjustment of the auxiliary idling stop should only be made when hunting occurs at the correct idling speed. If hunting does occur, ensure that it is not attributable to engine faults (such as faulty injectors) before making adjustments.

When double pitot venturi units are fitted, the positions of the idling stop on the venturi unit and of the air valve assembly in the diaphragm unit must be adjusted at the same time. Adjustment of either will affect the idling speed, and it is only by adjusting both settings simultaneously that a setting can be achieved where even running is obtained at the correct idling speed.

#### **MAINTENANCE**

The diaphragm is made of specially prepared leather and should give lasting service. It will be kept pliant by the addition of one tablespoonful of neat's-foot or castor oil through the oil cap (M. Fig. 1) at weekly intervals. Alternatively, a high grade non-detergent, mineral oil may be used.

Dustproofed pumps are not provided with the oil cap (M. Fig. 1), and the diaphragm is maintained in good condition by fuel oil mist.

When single pitot venturi units are fitted the diaphragm unit may be checked for leaks in the following manner :—

1. Disconnect the flexible pipe (E. Fig. 1) from the diaphragm unit.
2. Operate the stop control, thus moving the diaphragm and control rod to the "no fuel" position.

3. Seal off the pipe union on the diaphragm unit. A finger placed over the union will suffice.
4. Release the stop control.

After a small initial movement the control rod will remain stationary, providing there are no air leaks in the diaphragm unit. Should the control rod move when the "stop" control is released, check the joint between the governor housing and the governor cover, and the union on the governor cover. If these joints are air-tight, the diaphragm is at fault and must be renewed.

When double pitot venturi units are fitted both flexible pipes must be removed and the pipe unions blanked in similar fashion while the test is carried out.

Check the control linkage between the accelerator pedal and the butterfly valve in the venturi unit. Slackness in the linkage can cause uneven running which will be particularly noticeable at idling.

The air filter above the venturi unit must be cleaned at regular intervals which will depend on the conditions under which the engine is operating. Clogging of the air filter will result in reduced airflow through the venturi unit, and consequent reduction in the efficiency of the governor.

The "stop" control should be checked for freedom of movement at frequent intervals.

#### **CAUTION**

**After completion of an overhaul ensure that there are no air leaks between the venturi unit and the induction pipe on the engine, and that the flexible pipe (or pipes) is correctly fitted and the unions tightened. Check the diaphragm unit for leaks and ensure that the controls are connected and function correctly when the accelerator pedal is operated. The air filter must be fitted before the engine is started.**

**THE ENGINE MUST NOT BE STARTED BEFORE THE VENTURI UNIT, FLEXIBLE PIPE OR PIPES, OR THE AIR FILTER ARE FITTED, AND THE RECOMMENDED CHECKS FOR AIR TIGHTNESS ARE CARRIED OUT. Failure to observe this warning may result in serious damage to the engine caused by over-speeding.**