

Publ. No. 2492B  
March 1974



**AB VOLVO PENTA**  
BOX 392 S 401 26 GÖTEBORG 1 SWEDEN



Publ. No. 2492B  
March 1974

**instruction book**

**VOLVO PENTA**  
**marine diesel engine**

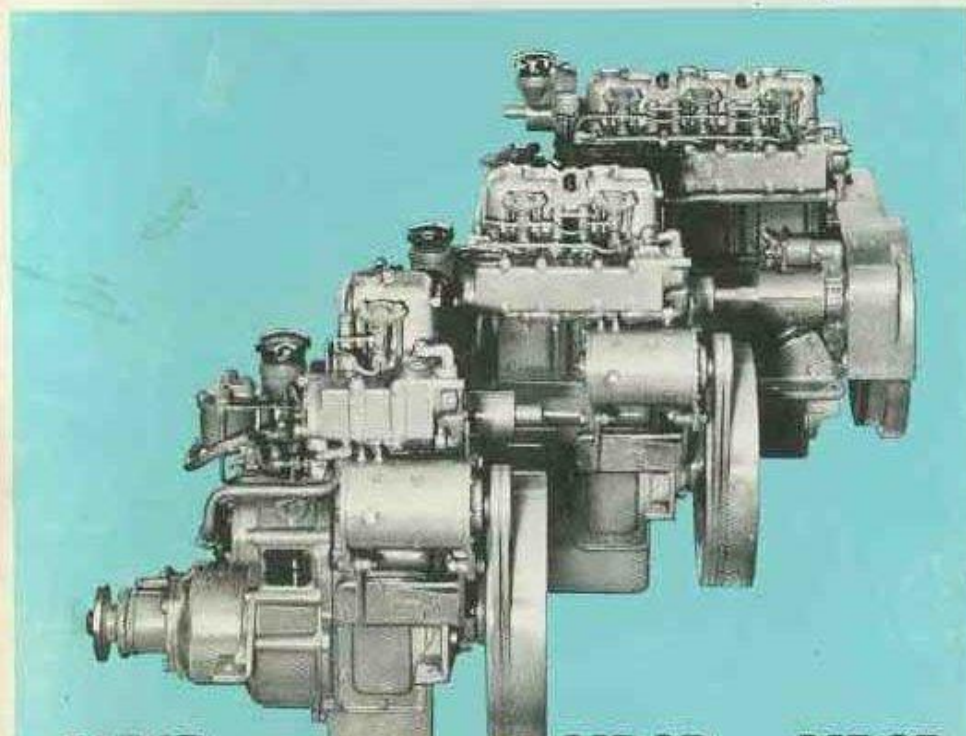

## FOREWORD

Before you start using your new Volvo Penta marine engine, we recommend you to read this instruction book carefully. It contains all the instructions you need to run and service your engine in the best possible way.

The dependability and the lifetime of your engine and equipment depend to a great extent on how these units are given service and maintenance. Always closely follow the instructions included in this book.

Volvo Penta has built up a world-wide service organization including service workshops with specially-trained personnel at your service.

Always contact your nearest Volvo Penta representative should you need advice and also when you require service or spare parts.

We are completely convinced that the demands concerning good running economy and outstanding performance you have every right to make on a high-quality product such as this, will be more than satisfied and that your Volvo Penta will provide you with a long period of faithful service.

## GUARANTEE

Every engine is accompanied by a warranty certificate which entitles the first purchaser to a guarantee concerning both material and labour. The extent of the guarantee is shown in the warranty card and we recommend you to read this carefully.

This certificate contains report forms which are filled in by the dealer and/or boatbuilder.

If our guarantee is to be valid, we make one absolute condition and that is that the checking procedures in the maintenance scheme are carried out and that your engine and its equipment are always looked after in accordance with the instructions in this book. When in doubt, please always contact a Volvo Penta authorized dealer.

In all correspondence with your dealer and also when ordering spare parts, always state the type designation and serial number of the engine and reverse gear (see starboard side of the engine).

## CONTENTS

<b>Presentation</b> .....	2-3
<b>Running the unit</b>	
Instrumentation and controls .....	4
<b>GENERAL INSTRUCTIONS</b>	
Fuel and lubricating oil recommendations .....	5
Running-in .....	5
Recommended engine speed .....	5
Precautions to be taken in case of frost .....	6
<b>RUNNING</b>	
Procedure before starting .....	6
Starting .....	6
Stopping .....	8
<b>Technical description</b>	
Engine unit .....	9
Fuel system .....	10
Lubricating system .....	10
Cooling system .....	10
Electrical system .....	10
Wiring diagrams .....	11-12
Reverse and reduction gear .....	13-14
<b>Servicing</b>	
Maintenance scheme .....	15
Periodical servicing .....	16-22
General servicing instructions .....	23-29
<b>Technical Data</b> .....	
<b>Tracing faults in case of running interruptions</b> .....	32

## PRESENTATION

MD3B type engine 3-cyl.—36 h.p.

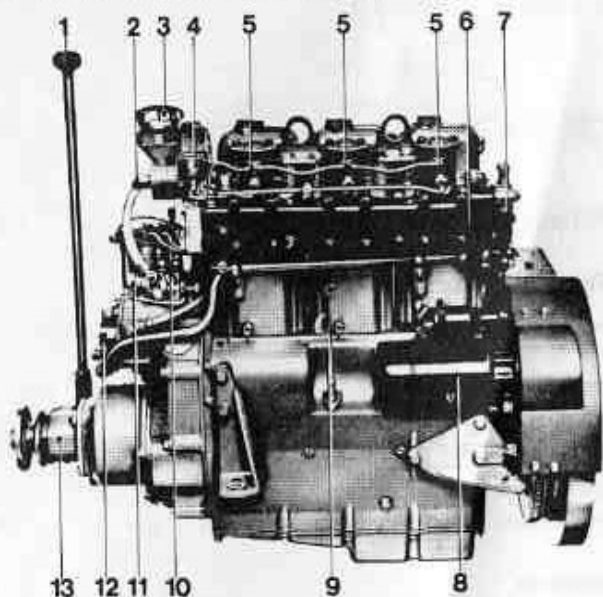

Fig. 1. MD3B, with RB reverse gear, starboard side (Reference numbers, see page 3)

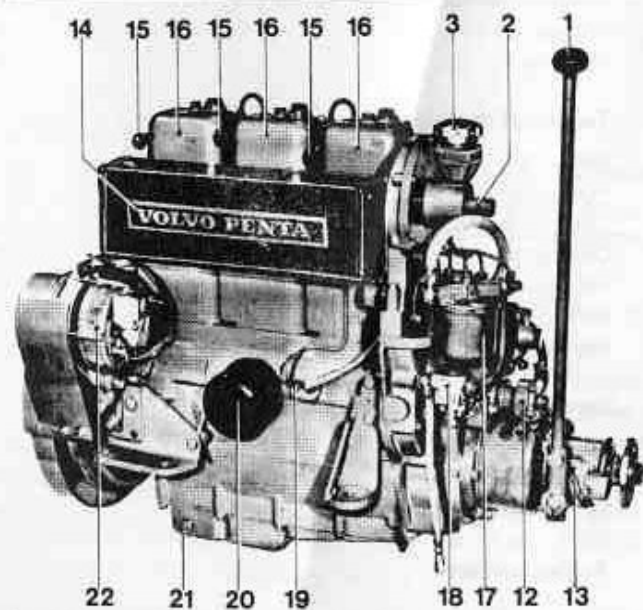

Fig. 2. MD3B, with RB reverse gear, port side (Reference numbers, see page 3)

## PRESENTATION

MD2B type engine 2-cyl.—25 h.p.

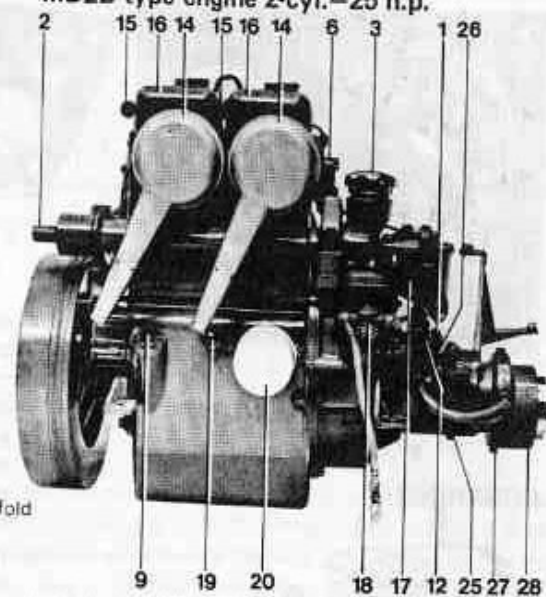

Fig. 3. MD2B, with MS reverse gear, port side

MD1B type engine 1-cyl.—10 h.p.

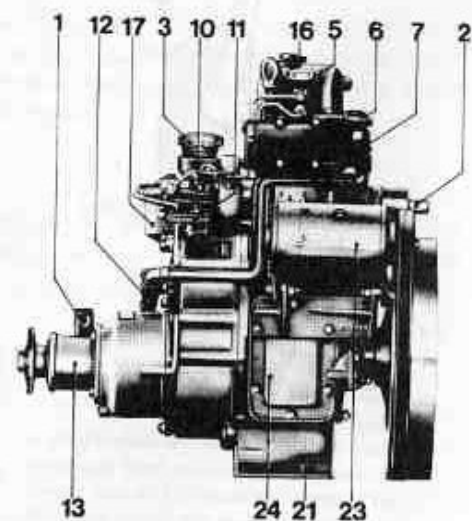

Fig. 4. MD1B, with RB reverse gear, starboard side

1. Shift control lever
2. Hand start shaft
3. Oil filler cap, engine
4. Oil pressure gauge
5. Injector
6. Water-cooled exhaust manifold
7. Thermostat housing (distributing housing)
8. Starter motor
9. Oil dipstick
10. Fuel injection pump
11. Control arm
12. Sea-water pump
13. Reduction/reverse gear RB 1.87:1
14. Air cleaner with silencer
15. Decompression lever
16. Rocker arm cover
17. Fuel filter
18. Fuel feed pump
19. Oil pressure sender
20. Oil filter
21. Oil drain plug, engine
22. Alternator
23. Starter-generator
24. Inspection covers
25. Oil drain plug, reverse gear
26. Oil filler plug, reverse gear
27. Water drain plug, reduction gear
28. Reduction/reverse gear MS 1.91:1

## RUNNING THE UNIT

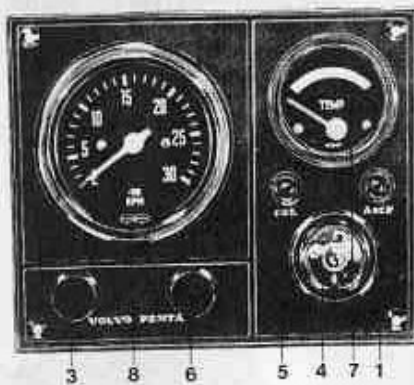

Fig. 5. Instrument panel, MD2B, MD3B

## CONTROLS

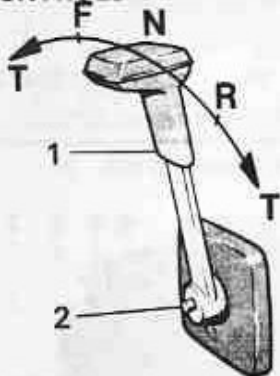

Fig. 7. Volvo Penta Single Control System

N = Neutral position  
F = Forward position  
R = Reverse position  
T = Throttle

1. Control lever
2. Neutral throttle knob  
Push the button when the control lever is in neutral and move the lever forward a bit. Release the button. The gear cannot be engaged. Push in the button again and pull back the lever for synchronized throttling and shifting.

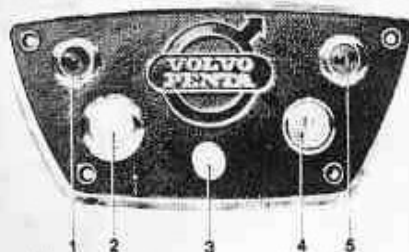

Fig. 6. Instrument panel, MD1B

1. Warning lamp for battery charging  
Red light — no charging
2. Starter button (MD1B)
3. Switch for extra electrical equipment
4. Key switch. For MD2B and MD3B with built-in starter
5. Warning lamp for oil pressure Red light — Stop engine, insufficient oil pressure.
6. Switch for instrument lighting
7. Temperature gauge for cooling water Green field — normal cooling water temperature
8. Revolution counter

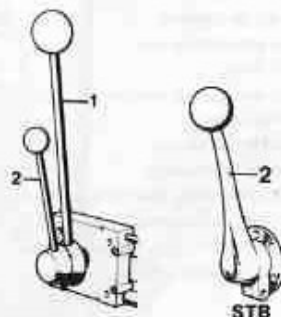

Fig. 8. D4, controls for RB mechanical reverse gear. STB, speed control

1. Gear shift lever
2. Engine speed control

## RUNNING THE UNIT

## GENERAL INSTRUCTIONS

### FUEL AND LUBRICATING OIL RECOMMENDATIONS

NOTE. Our guarantee only applies on condition that the following fuel and lubricating oil recommendations are followed.

#### Fuel quality

Only diesel fuel oils of quality "AUTO-DIESEL", specially intended for rapid diesel engines, may be used. Do not use fuel oils of lesser quality since these can easily cause damage to the fuel injection pump and injectors.

#### Lubricating oil quality

Modern, rapid marine diesel engines require high-class lubricating diesel oils. It is therefore absolutely essential that the right type of lubricating oil quality is used. For the engines, only lubricating diesel oil of quality "Service CD" according to the API-system, should be used. This oil contains additives which ensure maximum engine life under various conditions of operation.

### RUNNING-IN

When your marine engine is new, we recommend that you run it with a certain amount of care during the first 20 hours of operation. During this period, never subject the engine to full loading for more than brief periods, because it is during this time that the moving parts wear in together.

#### Oil changes

During the running-in period, the engine lubricating oil should be changed more frequently than usual. Change the engine oil and the oil filter after 20 hours of operation, see also under "Servicing", points 3 and 5.

### RECOMMENDED ENGINE SPEED

In order to obtain best running economy, the engine r.p.m. should be at 300 r.p.m. below the maximum speed reached when running for a longer period.

NOTE. When the boat has been in the water for some considerable time, maximum engine speed can decrease if there is marine growth on the bottom of the boat. Use

## RUNNING THE UNIT

Note! The speed control must always be moved to half throttle before the cold starting device is engaged. The cold starting device disengages automatically when the engine has started and reached the speed corresponding to the actual setting of the speed control lever. NEVER RACE A COLD ENGINE. Check after running the engine warm that the cold starting device on the MD1B and MD2B engines is disengaged by seeing whether the cold starting button has returned to its upper position.

To facilitate hand-starting during cold weather, crank the engine slowly a few revolutions with the decompression lever in vertical position. If an engine with electrical starting does not start at the first try, make a short pause before trying again in order to give the battery and starter motor a chance to recover.

## STOPPING

1. Move the control lever to neutral position and let the engine run some minutes at idling speed before stopping it.
2. Move the speed control past the idling position (spring idling stop). This shuts off the fuel injection and the engine stops. The engine should not be stopped by using the decompression handle.
3. For an engine with electrical equipment:

Turn the key switch to neutral position when the engine has stopped. **NOTE. The master switch must never be switched off before the engine has completely stopped.**

4. Switch off the master switch (if fitted) and close the fuel and cooling water cocks if the unit is to remain idle for some considerable time.
5. If the unit is to remain idle for more than two weeks, special inhibiting measures must be taken with the engine (see under "Procedure if unit is to remain idle").

If the engine has electrical equipment, this equipment should be sprayed regularly with fluid which protects against corrosion and moisture.

## TECHNICAL DESCRIPTION

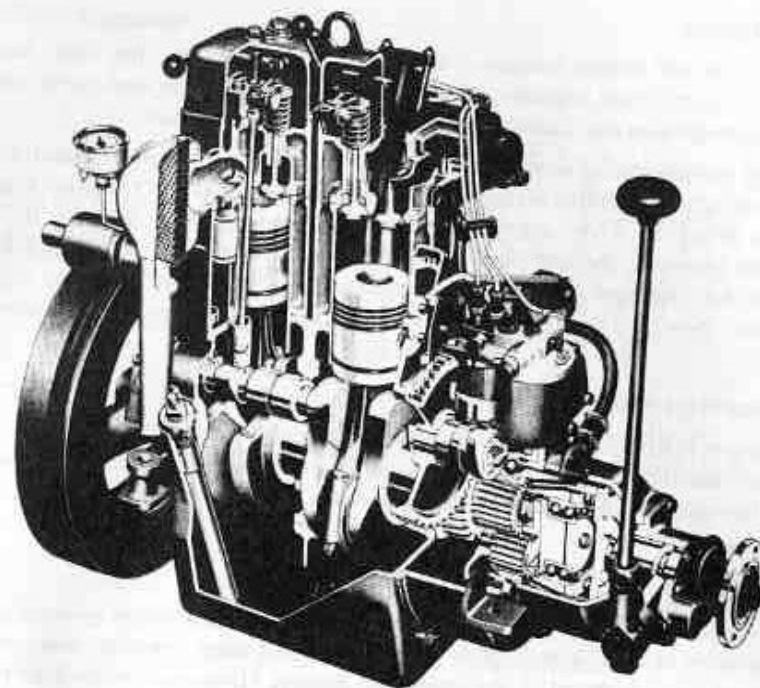

Fig. 10. MD2, cross-section

## TECHNICAL DESCRIPTION

### Engine unit

The MD3B, MD2B and MD1B are designed in accordance with the same principles and are specially constructed for marine use.

The crankcase, cylinders and cylinder head are made of special cast iron. The cylinder bores, which are surrounded by cooling jackets, are drilled directly in the cylinders.

On the MD3B the crankshaft is carried in 4 main bearings, on the MD2B in 3 and on the MD1B in 2 main bearings. The bearing shells are replaceable and are faced with indium-plated lead-bronze. The main and big-end bearing pins are surface-hardened.

## TECHNICAL DESCRIPTION

### Fuel system

The engine fuel system consists of a feed pump with pre-filter, fine filter, fuel injection pump, speed regulator, injectors and fuel lines. The fuel feed pump is of the diaphragm type and is actuated by a cam on the engine camshaft.

A hand priming device on the feed pump makes it possible to pump forward the fuel even when the engine is stopped. The fuel injection pump is of the piston type and is driven by a cam on the camshaft. The speed regulator, which is built into the housing at the fuel injection pump, regulates the amount of fuel supplied to the fuel injection pump during operation. To facilitate starting during cold weather, there is a special cold starting device built together with the injection pump.

### Lubricating system

The engine is fitted with a complete pressure lubricating system. The oil filter is of the full-flow type and is replaceable as a unit. It is provided with an overflow valve. The lubricating system has a relief valve which prevents the oil pressure from reaching excessive values.

### Cooling system

The engine is sea-water cooled and fitted with a thermostat which controls the temperature of the engine. Cooling water circulation is taken care of by means of a sea-water pump mounted on the timing gear housing. The pump is driven from the camshaft through a flange.

When the cooling water has passed through the engine, it is led either overboard or through the exhaust line.

### Electrical system

The MD3B and MD2B with MS gear is equipped with a starter motor and alternator as standard. The voltage is 12 volts.

As alternative equipment, the MD2B and MD1B are equipped with dynastart, which means that the generator and starter motor are combined and are driven by vee-belts from the engine flywheel.

#### WARNING

Never break the circuit between the alternator and battery while the engine is running. To do this would be to ruin the charging regulator immediately.

Do not switch off the master switch until the engine has stopped. See also under "Servicing", point 15.

## TECHNICAL DESCRIPTION

### Wiring diagrams:

#### Cable marking

Mark	Colour	sq. mm	AWG
A''	Ivory	2.5	13
B	Black	1.5	15
C <sup>a</sup>	Red	25	3
C	Red	2.5	13
D	Green	1.5	15
D**	Green	2.5	13
G	Brown	1.5	15
H	Blue	1.5	15
H <sup>a</sup>	Blue	25	3

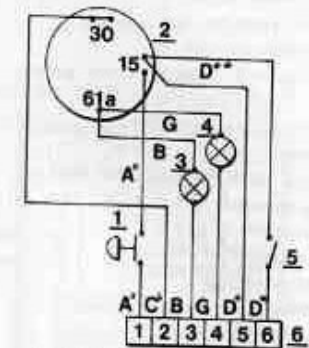

INSTRUMENT PANEL

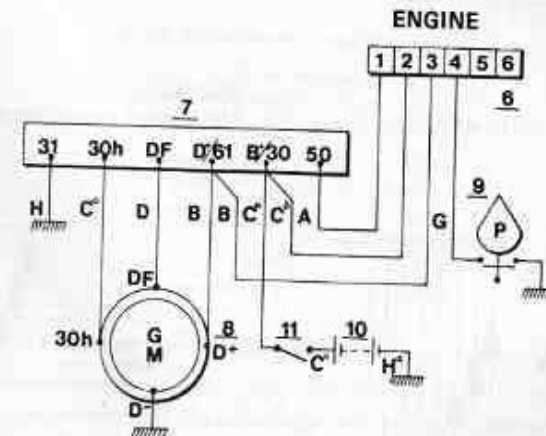
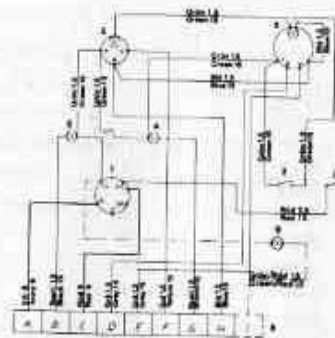

Fig. 11. Wiring diagram for MD1B

- |                                    |                              |
|------------------------------------|------------------------------|
| 1. Starter button                  | 7. Charging regulator        |
| 2. Key switch                      | 8. Starter-generator         |
| 3. Battery charging warning lamp   | 9. Oil pressure sensor       |
| 4. Oil pressure warning lamp       | 10. Battery 12 V, max. 60 Ah |
| 5. Switch                          | 11. Master switch            |
| 6. Connection terminal, instrument |                              |

WIRING DIAGRAMS

1. Key switch
2. Switch, inst. lighting
3. Temperature gauge
4. Warning lamp for "low pressure"
5. Revolution counter
6. Warning lamp, changing starter generator
7. Switch, extra equipment
8. Connector
9. Warning lamp, changing alternator (extra equipment)
10. Battery
11. Master switch
12. Starter generator
13. Alternator (extra equipment)
14. Charging regulator
15. Fuse
16. Temperature sender
17. Revolution sender
18. Oil-pressure sender
19. Other el. equipment
20. Starter motor
21. Alternator



INSTRUMENT PANEL, MD3B, MD2B

ENGINE  
MD3B, MD2B (with starter motor)

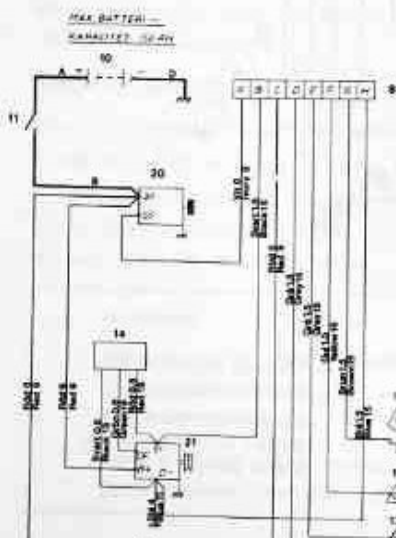

ENGINE  
MD2B (with starter generator)

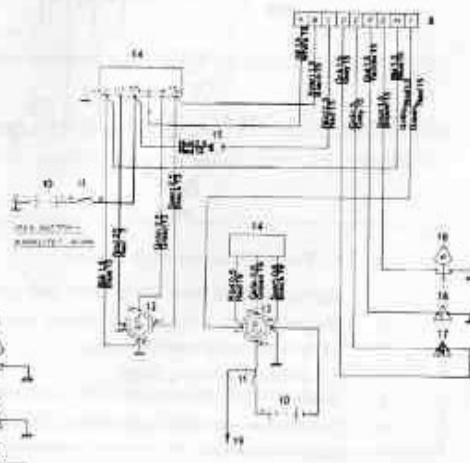

REVERSE AND REDUCTION GEAR

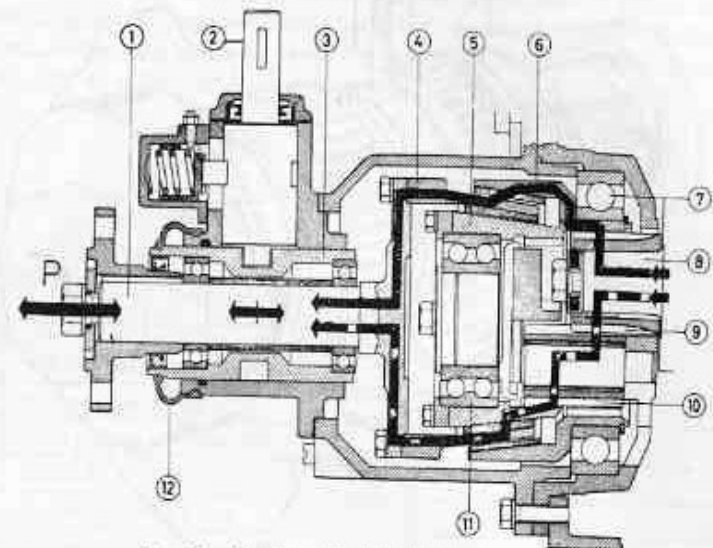

Fig. 13. Reverse and reduction gear

"Forward" = Thick unbroken line  
 "Reverse" = Thick broken line  
 P = Propeller thrust

- |                      |                     |
|----------------------|---------------------|
| 1. Output shaft      | 7. Ball bearing     |
| 2. Manoeuvring shaft | 8. Input shaft      |
| 3. Bearing sleeve    | 9. Input shaft gear |
| 4. Cone              | 10. Reverse gear    |
| 5. Gear with cone    | 11. Ball bearing    |
| 6. Gear with cone    | 12. Sealing         |

Reverse and reduction gear, type RB

Volvo Penta reverse and reduction gear type RB has a built-in reduction gear with ratio 1.87:1. As alternative, the RB-reverse gear has an auxiliary gear which gives a total reduction of 3.42:1.

"Forward" or "Reverse" is engaged through self-adjusting cones. These cones, which are axially displaceable, are held engaged for the most part (only RB-reverse gear) with the help of the propeller thrust, and for the most part by the axial force from the helical gears in the auxiliary gear (only RB-reverse gear with auxiliary gear). For the RB-reverse gear, the propeller shaft flange has axial movement when "Forward" or "Reverse", is engaged. For the RB-reverse gear with auxiliary gear, this movement is taken up inside the reverse gear.

## TECHNICAL DESCRIPTION

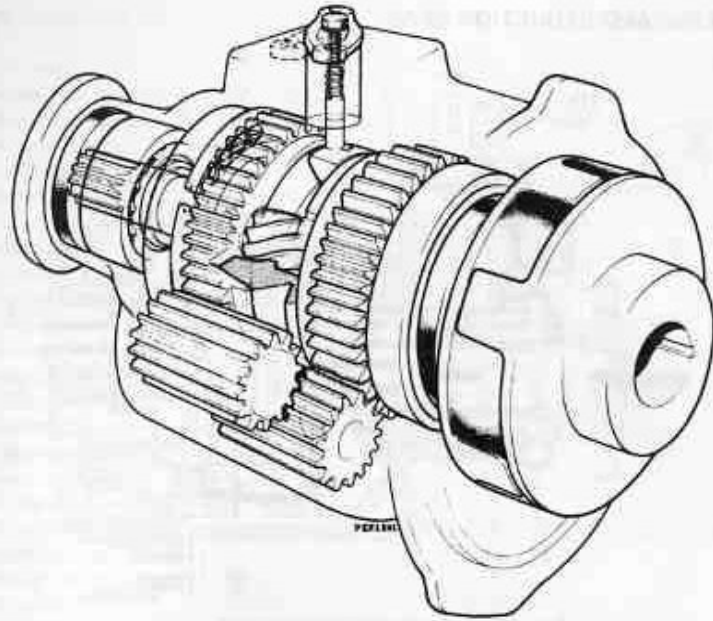

Fig. 14. Cross-section through MS-reverse gear

### Reverse gear, type Mono Shift (MS)

The Volvo Penta reverse gear, type Mono Shift, has a reduction gear with reduction ratio 1.91:1. The reduction gear is integrally built with the reverse gear.

Power is transmitted from the engine to reverse gear through a rubber flange.

For manoeuvring "Forward" and "Reverse", the Volvo Penta patented cone clutch is used. With this type of clutch, engagement is both smooth and quiet. Little force is required to operate the reverse gear.

The engaging power of the cone clutch is influenced by the size of the power transmission torque. The greater the torque, the stiffer will be the clutch engagement with increased throttling.

## PERIODICAL SERVICING

### MAINTENANCE SCHEME

The numbers of the servicing procedures below refer to the detailed descriptions on the following pages. Some of these operations require specialized mechanical knowledge and the use of special tools. For this reason, these operations should be carried out by an authorized service workshop.

See point	Operation	Daily before first start	After <sup>1)</sup> 50 hours running	After <sup>1)</sup> 100 hours running
<b>PERIODICAL SERVICING</b>				
1.	Check oil level in engine	•		
2.	Check oil level in reverse gear	•		
3.	Change oil in engine		•	
4.	Change oil in reverse gear		•	
5.	Change oil filter			•
6.	Clean air cleaner(s)			•
7.	Check vee belts		•	
8.	Check valve clearances			•
9.	Change fine filter and clean pre-filter			•
10.	Vent fuel system	• 2)		
11.	Check battery electrolyte level	• 3)		
<b>GENERAL SERVICING INSTRUCTIONS</b>				
12.	Check-tighten cylinder head nuts and cylinder head bolts	To be carried out according to the intervals given under respective points or when necessary		
13.	Check injectors			
14.	Cooling system			
15.	Electrical system			
16.	Check reverse gear			
17.	Procedure if unit is to remain idle and inhibiting			

1) Or once each season should this occur first

2) When necessary

3) Every fortnight



## PERIODICAL SERVICING

### 1. Checking oil level in engine

Check the oil level in the engine daily before starting for the first time. The dipstick is located on the port side of the engine (starboard side on MD3B) and has upper and lower markings. The oil level should be between both these markings (do not screw down the dipstick when measuring the level). It must never be allowed to go down below the lower mark and it should not be above the upper mark since this can result in abnormally high oil consumption. When necessary, fill up with oil through the filler hole (2, Fig. 16) in the cover for manual starting. NOTE: Check that the dipstick sealing ring is not damaged and screw down dipstick (MD1B and MD2B).

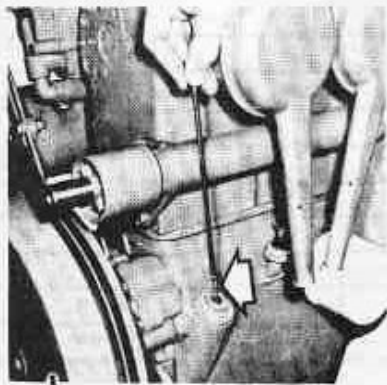

Fig. 15. Checking oil level



Fig. 16. Filling oil

1. Filling with oil after oil change
2. Topping up in connection with oil check

### 2. Checking oil level in reverse gear

The oil level in the RB-reverse gear does not need to be checked since the engine and reverse gear have one and the same oil compartment.

The MS-reverse gear has a separate oil compartment. Check the oil level daily before starting for the first time with the help of the dipstick which is located on the starboard side of the reverse gear. The oil level should be between the max. - min. area on the dipstick (which must not be screwed down when measuring). When necessary, top up with the same oil as used in the engine (see point 4).

## PERIODICAL SERVICING

### 3. Changing the engine oil

Change the lubricating oil after every 50 hours running or at least once each season. During the running-in period the oil should be changed after 20 hours of operation.

Run the engine warm before changing the oil. The oil is sucked up from the crankcase with the help of a crankcase pump, the tube of which is inserted through the dipstick hole (see Fig. 17). On the MD2B engine the oil strainer must be removed in order to be able to suck out the oil. Check to make sure that the oil strainer packing seals properly when the oil strainer is re-fitted. The crankcase pump is included in the tool kit and is supplied as accessory. If there is enough room, the oil can also be drained through the drain hole on the crankcase. Fill up with oil after oil change through the filler hole 1, Fig. 16.

Use only diesel lubricating oil, quality Service CD<sup>1)</sup>, see table.

QUALITY	VISCOSITY		OIL CAPACITY			incl. filter
	below +20°C (68°F)	above +20°C (68°F)	engine incl. RB-reverse gear litres (Imp. qts. = US qts.)			
Service CD <sup>1)</sup>	SAE 10W	SAE 20	MD1B - 1.7 (1.5 - 1.8)	MD2B - 3.0 (2.6 - 3.2)	MD3B - 5.5 (4.8 - 5.8)	+0.25 (0.25 qt.)



Fig. 17. Sucking up oil

### 4. Changing oil in reverse gear

Change the lubricating oil in the reverse gear after every 50 hours running or at least once each season.

#### Reverse gear typ RB

The reverse gear has the same oil compartment as the engine so that it has the same oil change as for the engine.

## PERIODICAL SERVICING

### Reverse gear typ MS

The oil is drained from the reverse and reduction gear through the reverse gear drain hole or is sucked up with the help of an oil scavenging pump through the hole for the dipstick. When adding oil to the reverse and reduction gear, fill up to the upper mark on the oil dipstick, see table below.

REVERSE GEAR TYPE	OIL QUALITY	VISCOSITY		OIL CAPACITY	
		below +20°C (68°F)	above +20°C (68°F)	litres (Imp. qts. = US qts.) incl. red. gear min.	max.
MS	Service CD 1)	SAE 10W	SAE 20	0,50 (0,44 = 0,53)	0,60 (0,53 = 0,64)

### 5. Changing the oil filter

Change the oil filter after every 100 hours running at the same time as the oil is changed. In the case of a new or reconditioned engine, the oil filter should also be changed for the first time after 20 hours running (see "Running-in the engine").

The oil filter is changed as follows:

Unscrew the old filter (see Fig. 18). If it remains firmly in position and cannot be loosened, use a special tensioning tool or pierce the outer part of the filter with a screwdriver that can then be used as a lever. Remember that oil can spill out.

Smear the new filter rubber gasket with oil and make sure that the contact surface against the oil cooler is clean. Screw on the filter by hand until it just comes into contact with the contact face on the oil cooler.

Tighten the filter a further half turn but no more. Start the engine and run it at idling speed while you check that there is no leakage at the filter.

Always check the oil level after changing the oil filter or changing the engine oil.



Fig. 18. Changing oil filter

1) Earlier "Service DS".

## PERIODICAL SERVICING

### 6. Cleaning the air cleaner(s)

The air cleaner should be removed and cleaned after every 100 hours running, or once each season.

1. Release the clamps with a screwdriver and remove the cleaners.
2. Clean the air cleaners in fuel oil. Soak them in engine oil.
3. Allow the engine oil to run off and re-fit the cleaners.

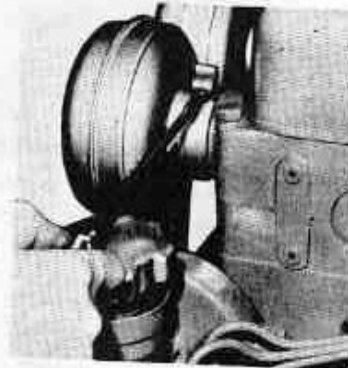

Fig. 19. Cleaning air cleaner

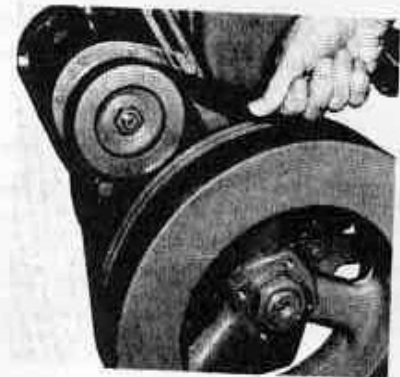

Fig. 20. Checking belt tension

### 7. Checking the vee-belts

Check the vee-belt tension after every 50 hours running. The belts can start slipping due to wear or grease.

Test the belt tensioning by pressing in the belts midway between the starter-generator and flywheel. It should be possible to press them in about 3-4 mm (1/8") under normal thumb pressure, see Fig. 20.

If an alternator is fitted, the vee-belt tension should be so hard that it is just possible to get the pulley to slip by turning with one finger a wing on the alternator fan.

If the belt is insufficiently tensioned, loosen the tensioner arm as well as the bolts at the alternator attaching points. Tension the belt by moving the alternator outwards and re-tighten the screws.

## PERIODICAL SERVICING

### 8. Checking valve clearances

**Check the engine valve clearances after every 100 hours running or at least once each season.** This check should be carried out by an authorized service workshop. **Adjustment must be made with the engine stopped.**

Observe the valves while cranking the crankshaft with the help of a starting handle. When both the valves in a cylinder "rock", which means that both valves are partly open, crank the crankshaft one turn further. Then check and if necessary adjust the valve clearance for this cylinder. Repeat this procedure for the second and third cylinder.

With the engine warm, the clearance should be 0.30 mm (0.012") for the inlet valve and 0.35 mm (0.014") for the exhaust valve.

### 9. Changing fine filter and cleaning pre-filter

**Change the fine filter after every 100 hours running, or at least once each season.** Thoroughly clean the whole of the outside of the filter body (see Fig. 23). Remove the centre bolt on the cover and take down the container and filter. Clean the inside of the container thoroughly. Check to make sure that the packings are not damaged. Fit a new filter. Vent the fuel system (see point 10).



Fig. 21. Feed pump with pre-filter.

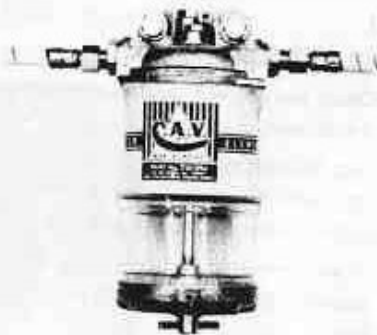

Fig. 22. Extra fuel filter with water separator

## PERIODICAL SERVICING

**Clean the pre-filter after every 100 hours running, or at least once each season.**

Wash the outside of the feed pump clean and remove the pre-filter, see Fig. 21. Clean the pre-filter in fuel oil and re-fit it with the pins facing upwards. Check the packing and tighten the plug. Vent the fuel system (see point 10).

If an extra fuel filter with separator is fitted (see Fig. 22), check the transparent container to see if any water has mixed with the fuel. If necessary, drain through the drain cock in the bottom of the filter container. Remember that fuel can spill out. The fine-filter element should be replaced at least once each season.

### 10. Venting the fuel system

1. Open the vent screw on the fine filter, Fig. 23.
2. Pump forward fuel with the help of the hand primer until about 0.5 litre (1 pint) has run out. Close the vent screw.
3. Open the vent screw on the fuel injection pump and pump forward fuel until fuel free from air bubbles flows out. Close the vent screw.

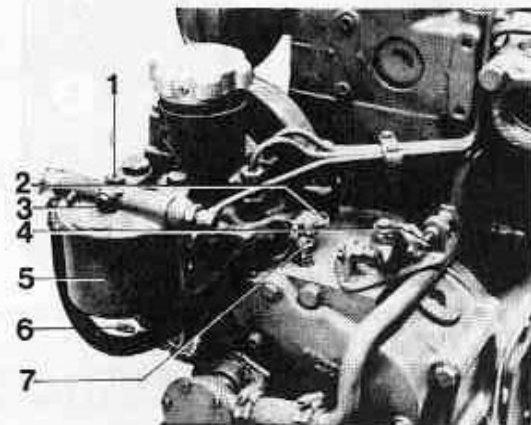

Fig. 23

1. Centre bolt
2. Vent screw, injection pump
3. Vent screw, fine filter
4. Idling position, adjustable  
Spring-loaded stop position
5. Fine filter
6. Hand primer
7. Cold start button

## GENERAL SERVICING INSTRUCTIONS

### 11. Checking electrolyte level in battery

Check the battery electrolyte level at least every 14 days.

The level should be between 5 and 10 mm (1/4 and 1/2") over the cell plates. Add distilled water whenever necessary. Never add too much since the electrolyte can then splash out and cause corrosion damage. Never check the electrolyte level by using a lighted match since gas formed in the battery cells is highly explosive.

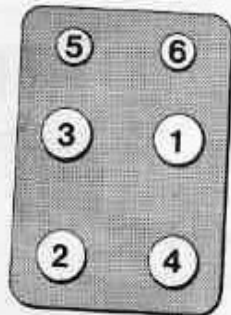

Fig. 24. Tightening sequence for cylinder head bolts and cylinder head nuts

Tightening torques:

Nos. 1, 2, 3 and 4 to be tightened to 11 kpm (80 lb.ft.)

Nos. 5 and 6 to be tightened to 4.5 kpm (33 lb.ft.)

### 12. Check-tightening cylinder head nuts and cylinder head bolts

With a new engine or when the cylinder head has been removed, the cylinder head nuts and cylinder head bolts should be re-tightened after 20 hours running and when the engine is warm. Check-tightening should also be carried out once each season. Use a torque wrench for all tightening of the cylinder head. Concerning tightening torques, see text Fig. 24. Valve clearance should always be adjusted after the cylinder head nuts and cylinder head bolts have been tightened. Concerning tightening sequence, see Fig. 24 (page 22).

### 13. Checking the injectors

At regular intervals all the injectors should be removed and handed in to a diesel workshop for cleaning and a check on opening pressure, leakage and spray pattern. We recommend an interval of max. 100 hours of operation between these inspections.

#### REMOVING

1. Clean the injector, delivery pipe and cylinder head around the injector.
2. Unscrew the clamp, delivery pipe and leak-oil line from the injector. Fit protective caps.
3. Unscrew both the nuts over the yoke holding the injector to the cylinder head and lift up the injector. If carbonizing has stuck the injector, turn the injector forwards and backwards carefully with, for example, general purpose pliers and at the same time lever upwards (e.g. with a screwdriver under the lug).

#### FITTING

1. Check that the contact surface on the injector and copper sleeve is clean.
2. Push the injector down into position and fit the yoke but do not tighten the nuts.
3. Connect the delivery pipe and return line. Make sure that the cones are in correct position. Do not forget to fit the clamp in position, otherwise the life of the pipes will be shortened.
4. Tighten the retaining nuts on the yoke. Concerning tightening torque, see under "Technical Data".

## SERVICING INSTRUCTIONS

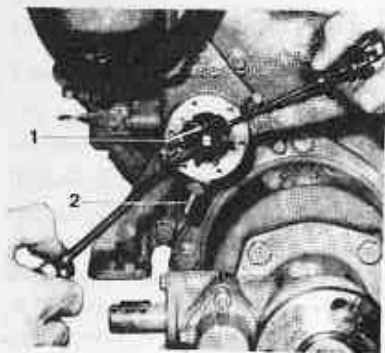

Fig. 25. Removing impeller

1. Lock bolt
2. Suction side

### 14. Cooling system

The cooling system should be checked after 100 hours running, or at least once each season, for leakage, deposits, etc.

The thermostat can be taken out after the water distributor housing on the front end of the exhaust manifold has been removed. Concerning functional temperature, see under "Technical Data".

### REPLACING THE SEA-WATER PUMP IMPELLER

The pump impeller is made of neoprene rubber and this can be damaged in the case of water deficiency, for example, if the sea water intake should be blocked. The pump impeller is changed as follows:

1. Remove the cover from the sea-water pump. **Note the risk of water getting into the boat.** With the help of two screwdrivers pull the shaft with the pump impeller out of the housing as far as necessary to reach the bolt retaining the impeller. See Fig. 25. **NOTE:** Place some kind of protection under the screwdrivers in order not to damage the impeller housing.
2. Pull the impeller off the shaft. Clean the inside of the pump housing and fit the new impeller. Always have a spare impeller on board.
3. Check that the pump coupling is not damaged by trying to turn the pump impeller. Fit the cover with the original gasket which has the right thickness.

## SERVICING INSTRUCTIONS

### 15. Electrical system

#### CHECKING THE STATE OF CHARGE OF THE BATTERY

The state of charge of the battery should be checked at least once each season. This is done by using a hydrometer which shows the specific gravity of the electrolyte, this varying with the state of charge. (See under "Technical Data".)

#### CABLES AND CABLE TERMINALS

At regular intervals check that all cable terminals are properly tightened and that there is no damage on any of the cables.

**NOTE.** This is particularly important when the engine is fitted with an alternator.

The battery poles and cable clamps should be well tightened and smeared with grease or vaseline.

#### STARTER-GENERATOR, STARTER MOTOR AND ALTERNATOR

All work on the starter-generator, starter motor and alternator should be carried out by an authorized service workshop. Inspection and control should be done when the engine is given a general overhaul.

#### WARNING!

**If the alternator and its regulator are to function perfectly, it is extremely important that the following instructions are carried out:**

1. Never break the circuit between the alternator and the battery while the engine is running. The result will be a short-circuit in the regulator which is immediately ruined.

**The master switch must never be switched off before the engine has completely stopped.**

2. Never confuse the battery poles with one another. The poles are generally stamped with a plus and a minus sign respectively. The minus pole must always be connected to the engine block.
3. Use only Volvo Penta double-diode kits when charging two batteries from one generator.
4. In the case of starting by using a spare battery, this should be done as follows:  
Let the ordinary battery remain connected in circuit. Connect the spare battery to the ordinary battery, plus to plus and minus to minus. When the engine starts disconnect the spare battery but never break the circuit to the ordinary battery.

## SERVICING INSTRUCTIONS

- Never use a rapid charger while the alternator is connected to the battery.
- Always disconnect both battery cables before carrying out any work on the alternator equipment.
- If electric welding work is to be carried out on the engine or installation units, disconnect the charging regulator cables at the alternator and insulate.
- Check vee belt tension and cable connections at regular intervals.

16.

### Checking the reverse gear

#### REVERSE GEAR TYPES RB AND MS

The reverse gear should be checked regularly for oil leakage, abnormal noise level or excessive operating temperature.

If a remote control is connected, it must be so designed that there is no constant pressure on the control components of the reverse gear. When reverse gear is engaged for "Forward" or "Reverse", the remote control should be completely off-loaded so that the propeller thrust can keep the reverse gear cones in the engaged position.

17.

### Procedure if unit is to remain idle

#### IDLE PERIOD WITH BOAT AFLOAT

In the case of an idle period of **less than one month** with the boat afloat, the engine should be started and run warm **after at least every 14 days** to prevent corrosion damage to the internal parts of the engine.

If the engine is to remain idle for a **longer period than one month** then the engine should be inhibited, see under "Procedure before laying up".

Protect the engine and equipment from external corrosion damage by regularly spraying unpainted surfaces and electrical components with corrosion and moisture protection spray.

We also recommend that the cylinders are sprayed through the injection holes in the case of long intervals of idleness.

#### PROCEDURE BEFORE LAYING UP

Before the boat is taken up on land for laying up, it is advisable to let an authorized service workshop test the engine and reverse gear. It is also advisable to carry out a compression test on the engine.

## SERVICING INSTRUCTIONS

### PREPARE THE ENGINE FOR LAYING UP BEFORE THE BOAT IS LIFTED OUT OF THE WATER AS FOLLOWS:

- Run the engine warm, stop it and pump all the lubricating oil out of the engine and reverse gear with the help of the crankcase pump. NOTE: Since the oil compartment for the MS-reverse gear is separate from that for the engine, its oil must be separately pumped out with a scavenging pump or drained.
- Fill up the engine and reverse gear with inhibiting oil to the lowest mark on the dipstick. Suitable inhibiting oils are Esso Rust Ban 623, Shell Ensis Oil 20 or corresponding oils of another make. NOTE: The MS-reverse gear must be filled separately.
- Drain off the fuel oil in the fuel filter and loosen the flexible fuel line from the tank at the bottom. Place the hose in a can with inhibiting oil containing 1/3rd Esso Rust Ban 623 and 2/3rds fuel oil.
- Vent the fuel system and start the engine. Run it at rapid idling until about 1/4 litre (about 1/2 pint) has been used up from the can.
- Stop the engine.

### AFTER THE BOAT HAS BEEN LIFTED ASHORE, CARRY OUT THE FOLLOWING PROCEDURE:

- Inhibit the cooling system as follows:
  - Drain off all cooling water from the engine and exhaust manifold by opening all drain cocks (on the starboard side), one for each cylinder, and drain points. When MS reverse-reduction gear is fitted also drain off the reduction gear through the bottom plug, see 27 Fig. 3.

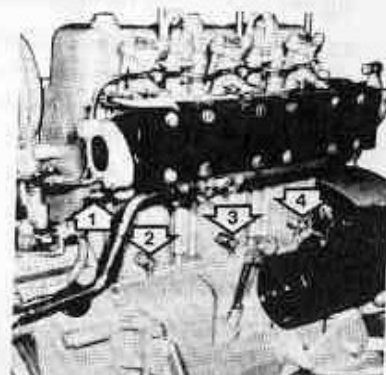

Fig. 26. Drain cocks for cooling water

MD1B cocks 1 and 2  
MD2B cocks 1, 2 and 3  
MD3B cocks 1, 2, 3 and 4

## SERVICING INSTRUCTIONS

- b. Mix rustproofing agent in a container filled with at least 20 litres (3 1/2 Imp. galls. = 4 1/2 US galls.) of fresh water. The rustproofing agent used should be of the emulsifying type, for example, Esso Cutwell 40, Shell Dorax C or similar. Add 20% rustproofing oil to the water and stir well. **NOTE.** Always add the oil to the water and never the other way round.
  - c. Disconnect the suction line between the cooling water pump and bottom intake from the pump. When MS-reverse-reduction gear is fitted the suction line between the reduction gear and bottom intake must be disconnected.
  - d. Instead connect a 1/2" (5/8" on MD3B) rubber hose, the length of which should be sufficient to reach down to the bottom of the container with rustproofing mixture.
  - e. Insert the connected suction hose into the container. Let the fuel line remain in the can with the mixture of inhibiting oil and fuel and start the engine. Let it run at idling until the water has been sucked out of the container, this forming a protective oil film in all the cooling channels. **NOTE. Never let the engine run dry since this can damage the cooling water impeller.** Then connect the cooling water hose to the bottom intake and the fuel hose to the feed pump.
  - f. Drain all cooling water from the engine by opening all the drain cocks, see Fig. 26. **The rustproofing mixture does not protect the engine from frost.**
  - g. Drain the cooling water pump by loosening the pump cover. Take out the impeller (see under "Servicing", point 14) for winter storage. Let the drive shaft remain in position and re-fit the cover. Drain the MS-reduction gear through the bottom plug, see 27 Fig. 3.
2. Remove the injectors and spray each cylinder with inhibiting oil. Then turn over the engine several turns before re-fitting the injectors. Concerning tightening torque for the injectors, see under "Technical Data".
  3. Clean the outside of the engine and reverse gear with white spirit or similar and touch up damaged paintwork. Protect all unpainted parts and the electrical system by spraying them with corrosion and moisture protective spray. Oil the ring gear (MD3B) on the flywheel and the starter motor pinion and its shaft with rustproofing oil.
  4. Remove the battery and put it into storage. It must be recharged at regular intervals if it is to be kept in good condition.

### PROCEDURE WHEN LAUNCHING:

1. Pump out all the rustproofing oil from the engine and reverse gear and replace the oil filter, see under "Servicing", points 3, 4 and 5. **NOTE.** The MS-reverse gear has a separate oil compartment.

## SERVICING INSTRUCTIONS

2. Fill the engine and reverse gear with lubricating oil, see under "Servicing", points 3 and 4.
3. Fit the pump impeller in the cooling water pump, see under "Servicing", point 14, and connect all hoses and check-tighten hose clamps.
4. Clean the outside of the engine and reverse gear of rustproofing oil.
5. Take a fully charged battery on board and connect up the battery cables. **NOTE. Be careful not to confuse the cables (see under "Servicing", point 15). The negative battery pole should be earthed to the engine.**  
  
Grease in the battery cable clamps with grease or vaseline after tightening.
6. Remove the injectors and turn over the engine several turns with the starter motor in order to blow out any rustproofing oil which may be on the piston tops. **NOTE.** Prevent oil splash. Re-fit the injectors, see under "Technical Data" for their tightening torque.
7. Close all drain cocks for the cooling system. Open the bottom cock for the cooling water intake.
8. Launch the boat and fill the fuel tank. Change the fine filter (see under "Servicing", point 9), pump forward fuel and vent the system (see point 10). Check thoroughly the tank, lines, connections and cocks to be absolutely sure that there is no leakage.
9. Start the engine and follow carefully the running instructions given on pages 6-8. Run the engine warm with the reverse gear engaged. Check to make sure there is no leakage of fuel, water, oil, air or exhaust gases. If there is, attend to it immediately. Check the bolts and nuts for tightness.
10. **Contact an authorized Volvo Penta service workshop and have servicing of the engine and reverse gear carried out as specified in the maintenance scheme.**

## TECHNICAL DATA

### General

Engine designation	MD3B	MD2B	MD1B
Number of cylinders	3	2	1
Output, h.p. (DIN) at 2500 r.p.m.	36	25	10
Max. operating speed, r.p.m.		2500	
Bore, mm (in.)		88.9 (3.50)	
Stroke, mm (in.)		90.0 (3.54)	
Displacement, litres (cu. in.)	1.68 (102.5)	1.12 (68.4)	0.56 (34.2)
Compression pressure, $\text{kp/cm}^2$ (p.s.i.), starter motor r.p.m.		20-24 (285-340)	
Idling speed, r.p.m.		550-650	
Direction of rotation, when facing flywheel		clockwise	
Max. inclination of engine in boat under way		15°	
Engine weight, incl. reverse gear, approx. kg (lb.)	290 (640)	220 (485)	165 (364)

### Valves

Valve clearances, warm engine:	
inlet, mm (in.)	0.30 (0.012)
exhaust, mm (in.)	0.35 (0.014)
Decompression device, max. depression of exhaust valve, mm (in.)	0.5 (0.020)

### Lubricating system

Engine incl. RB-reverse gear	
Oil capacity, engine, litres (Imp. qts. = US qts.), excl. filter	5.5 (4.8 = 5.8)
incl. filter	5.75 (5.0 = 6.0)
Oil quality	Diesel lubricating oil, Service CD <sup>1)</sup>
Viscosity	SAE 20
above +20°C (68°F)	
below +20°C (68°F)	SAE 10W
Oil pressure, warm engine:	
idling speed, $\text{kp/cm}^2$ (p.s.i.)	0.8-1.5 (14-21)
at full speed, $\text{kp/cm}^2$ (p.s.i.)	2.0-3.0 (28-43)
MS-reverse-reduction gear	
Oil capacity, litres (Imp. qts. = US qts.)	0.60 (0.53 = 0.64)
Oil quality	Diesel lubricating oil, Service CD <sup>1)</sup>
Viscosity	SAE 20
above +20°C (68°F)	
below +20°C (68°F)	SAE 10W

### Cooling system

Thermostat, starts opening at °C (°F)	57 (135)	60 (140)	75 (167)
is fully open at °C (°F)	72 (162)	75 (167)	90 (195)

1) Earlier "Service DS".

## TECHNICAL DATA

### Fuel system

Fuel injection pump, Bosch, MD1B	PFR 1K 75A/380/11
MD2B	PFR 2K 75A/381/11
MD3B	PFR 3K 75A/382/11
Feed pressure, $\text{kp/cm}^2$ (p.s.i.)	0.75 (11)
Injectors, Bosch, holder	KBL 87S78/4
spray nozzles	DLLA 150S720
opening pressure, $\text{kp/cm}^2$ (p.s.i.)	170-178 (2417-2531)
Pre-injection angle, crankshaft, degrees	23°-26°

### Reverse gear

Type	Volvo Penta RB
Reduction ratio "Forward"	1.87:1
Reduction ratio "Reverse"	1.7:1
Reduction ratio with auxiliary gear	3.42:1
Type	Volvo Penta MS
Reduction ratio with auxiliary gear	1.91:1

### Electrical system

Battery voltage	12
Battery capacity, max. Ah, MD3B	150
MD2B MD1B	60
Starter motor output, h.p., MD3B	2
Alternator output, max. W	450
Starter-generator MD2B, MD1B	
Generator output, max. W	135
continuous W	90
Starter motor output, h.p.	1
Battery electrolyte, specific gravity:	
Battery to be re-charged at $\text{g/cm}^3$	1.230
Fully charged battery, $\text{g/cm}^3$	1.275-1.285

### Tightening torques

Cylinder head bolts (width across flats, 19 mm = 3/4 in.) kpm (lb. ft.)	11.0 (80)
width across flats, 15 mm = 9/32 in.) kpm (lb. ft.)	4.5 (33)
Connecting rod bolts, kpm (lb. ft.)	6.5 (47)
Crankshaft main bearings (intermediate bearing), kpm (lb. ft.)	8.0 (58)
injector nuts, kpm (lb. ft.)	2.0 (14)



## TRACING FAULTS IN CASE OF RUNNING INTERRUPTIONS

The fault-tracing scheme below includes only the more usual reasons for faulty operation. With the help of the instructions given in this book it is usually possible to trace most of the causes mentioned below. In case of doubt always contact the nearest Volvo Penta service workshop.

Follow the instructions in the servicing scheme – this ensures the best running reliability.

### Fault-tracing scheme

Engine will not start	Engine stops	Engine does not reach top speed at full throttle	Engine runs roughly or vibrates abnormally	Engine overheats	FAULT TRACING	Remarks
x					Master switch not on; battery discharged, broken electric cable.	see points 11, 15
x	x				Fuel tank empty, fuel cock closed, fuel filter blocked	see points 9, 10
x	x		x		Water, air or impurities in fuel	see points 9, 10
x	x	x	x		Faulty injectors	see point 13
		x			Boat abnormally loaded, Marine growth on boat bottom	see page 5
		x	x		Propeller damaged	
				x	Blocked cooling water intake or cooling jackets, defective pump impeller or thermostat	see point 14

### Personal information

Name .....

Address .....

Phone .....

### Nearest Volvo Penta dealer

Name .....

Address .....

Phone .....

### Technical information

Engine type .....

Serial number, engine: .....

Reverse gear type: ..... Ratio: .....

Serial number, reverse gear: .....

Propeller size .....

.....

.....

.....

The specifications and constructional details given in this instruction book are not binding.

We reserve the right to make modifications without previous notice.

Technical Information Department  
AB VOLVO PENTA