

Workshop Manual

Fuel System

D
2(0)

**TAMD61A, TAMD62A, TAMD63L-A, TAMD63P-A
TAMD71A, TAMD71B, TAMD72A, TAMD72P-A, TAMD72WJ-A**

Group 23 Fuel System

Marine engines

**TAMD61A • TAMD62A • TAMD63P-A • TAMD63L-A
TAMD71A • TAMD71B • TAMD72A • TAMD72WJ-A
TAMD72P-A**

Contents

General instructions	2	Idle speed, adjustment	27
Special tools	9	Feed pump, replacement	28
Other special equipment	9	Feed pump, renovation	29
Design and function		Fuel supply pressure, checking	30
General	10	Fuel shut-off valve, trouble shooting	31
Injection pump	11	Fuel shut-off valve, renovation	31
Regulator	12	Seal in pump drive, replacement (TAMD61, -62, -71)	32
Pressure variable full load stop	15	Seal in pump drive, replacement (TAMD63, -72)	33
Feed pump	15	Injector, replacement	35
Overflow valve	16	Injector, renovation	36
Fuel injector	16	Copper sleeve, cleaning	36
Fuel shut-off valve (TAMD 63)	17	Recommendations for adjustment of opening pressure, adjustment pressure and replacement of fuel injectors	37
Fuel filter	17	Opening pressure, adjustment	38
Repair instructions	18	Fuel filter, replacement	39
Injection pump, removal	18	Fuel system, venting	39
Injection pump, installation and adjustment (TAMD61, -62*), -71, 72*)	20		
Injection pump, installation and adjustment (TAMD63**) and TAMD72P-A)	24		

* Not applicable for TAMD63P-A which is equipped with stroke position sensor, and TAMD72P-A.

** Not applicable for TAMD63P-A which lacks stroke position sensor.

Information on Safety

Introduction

The Workshop Manual contains technical data, descriptions and repair instructions for the products or product versions from Volvo Penta indicated in the contents. Make sure that the correct literature is used.

Read the following Information on Safety and the Workshop Manual's "General Information" and "Repair Instructions" carefully before service work is begun.

Important

The following special warning signs are used in the Workshop Manual and on the products.

 **WARNING!** Failure to follow the instructions can result in personal injury, extensive damage to the product or property, or serious malfunctioning.

 **IMPORTANT!** Used to attract attention to what can cause injury, malfunction, or damage to property.

NOTE! Used to attract attention to important information for the simplification of work processes or handling.

To provide a general understanding of the risks and precautions to which attention should always be given we have made the following list.

 Prevent starting the engine by switching off the power with the main switch(s) and locking it (them) before service work is begun. Attach a warning label on the instrument panel.

 All service work should as a rule be conducted with an idle engine. Some work, e.g. certain adjustments, require the engine to be running. Approaching an engine which is running is a safety risk. Remember that loose clothes or long hair can fasten in rotating parts and cause severe personal injuries.

If work is conducted in the vicinity of an engine which is running, an unintentional movement or dropped tool can lead to personal injury. Observe care with hot surfaces (exhaust pipe, turbo, air pressure pipe, starter element, etc.) and hot liquids in pipes and hoses on an engine which is running or has just been switched off. Refit all guards dismantled during service work before starting the engine.

 Make sure that the warning or information labels on the product are always clearly visible. Replace labels which have been damaged or painted over.

 Engines with turbo compressor: Never start the engine unless the air filter is fitted. The rotating compressor wheel in the turbo can result in serious personal injuries. Foreign objects in the intake can also result in damage to the engine.











 Never use start spray or the like to assist starting. This can cause explosion in the intake pipe. Risk of personal injury.



 Avoid opening the filler cap for coolant (fresh water cooled engines) when the engine is hot. Steam or hot coolant can spray out. Open the filler cap slowly and release the overpressure in the cooling system. Observe great care if the tap, plug or coolant pipe must be dismantled when the engine is hot. Steam or hot coolant can flow out unexpectedly.

 Hot oil can cause burn injuries. Avoid skin contact with hot oil. Make sure that the oil system is pressureless before starting work. Never start or run the engine with the oil fill cap removed in view of the risk of oil splash.

 Stop the engine and close the bottom valve before working on the cooling system.



 Only start the engine in a well ventilated area. When running the engine in enclosed areas the exhaust fumes and crankcase gases shall be led out of the engine compartment or workshop area.

-  Always use protective goggles when working where there is risk of splinters, sparks, splashing acid or other chemicals. The eyes are extremely sensitive, an injury can result is the loss of sight!
-  Avoid skin contact with oil! Prolonged or repeated skin contact with oil can lead to degreasing of the skin, resulting in irritation, drying out, eczema and other skin complaints. From the health aspect used oil is more dangerous than new. Use protective gloves and avoid oil drenched clothes and rags. Wash regularly, especially before meals. Use skin cream for this purpose to counteract drying out and to simplify cleaning of the skin.
-  The majority of chemicals intended for the product (e.g. engine and transmission oils, glycol, petrol and diesel) or chemicals for workshop use (e.g. degreasing agents, varnishes and solvents) are hazardous to health. Read the instructions on the pack carefully! Always follow prescribed safety instructions (e.g. the use of breathing protection, protective goggles and gloves, etc.) Ensure that other personnel are not unintentionally exposed to hazardous substances, e.g. via breathing the air. Ensure good ventilation. Handle consumed and excess chemicals in the prescribed manner.
-  Observe great care when looking for leaks in the fuel system and testing fuel injectors. Wear protective goggles. The jet from a fuel injector has a very high pressure and high penetration capacity; the fuel can penetrate deeply into body tissue and cause severe injuries. Risk of blood poisoning.
-  All fuel, in similarity with many chemicals, is inflammable. Make sure that naked flames or sparks cannot cause ignition. Petrol, certain thinners and hydrogen gas from batteries, are in the right proportions with air extremely inflammable and explosive. Smoking prohibited! Ventilate well and take the necessary safety precautions before welding or grinding work is begun in the vicinity. Always have a fire extinguisher easily accessible at the workplace.
-  Make sure that oil and fuel drenched rags, fuel and lubricant filters, are stored safely. Oil drenched rags can in certain circumstances self-ignite. Old fuel and oil filters are environmentally hazardous waste and should together with consumed lubricant, contaminated fuel, paint residue, solvent, degreasing agent and washing residue, be handed in to an environmental station for destruction.
-  Batteries must never be exposed to naked flames or electric sparks. Never smoke in the vicinity of batteries. Hydrogen gas develops during the charging of batteries, which in combination with air forms detonating gas. This gas is highly inflammable and very explosive. A spark, which can result from an incorrectly connected battery, is sufficient to cause the battery to explode and cause personal injury. Do not move the connection when starting (spark risk) and do not lean over the batteries.
-  Never confuse the plus and minus terminals when fitting the batteries. This can cause serious damage to the can cause serious damage to the wiring diagram.
-  Always use protective goggles during the charging and handling of batteries. The battery electrolyte contains strongly corrosive sulphuric acid. In the event of skin contact wash with soap and plenty of water. If battery acid has come in contact with the eyes, rinse immediately with water and contact a doctor without delay.
-  Stop the engine and switch of the power with the main switch(s) before working on the electrical system.
-  Adjustment of the clutch should be conducted on an idle engine.

-  Use the lifting hooks mounted on the engine/reversing gear when lifting the drive unit. Always check that all lifting tackle is in good condition and has the correct lifting capacity (weight of engine with reversing gear and extra equipment). For safe handling, and to avoid damaging components fitted on the top of the engine, the engine should be lifted with a lift-bar adjusted to the engine. All chains or wires should run parallel to each other and as far as possible at right-angles to the top of the engine. Special lifting tackle may be necessary if other equipment connected to the engine changes its centre of gravity, in order to achieve the correct balance and safe handling. Never work on an engine hanging in lifting tackle.
-  Never work alone when heavy components are to be dismantled, even when secure lifting tackle in the form of lockable pulleys are used. Two persons are normally required even when lifting tackle is used, one to manage the lifting

tackle and another to ensure that all components are unobstructed and not damaged during the lifting.

When working on board a boat always make sure in advance that there is sufficient space available to facilitate dismantling in situ, without risk of personal injury or damage to materials.

-  Components in the electrical system, in the ignition system (petrol engines), and in the fuel system on Volvo Penta products are designed and manufactured to minimise the risk of explosion and fire. The engine must not be run in environments containing explosive media.
-  Always use fuel recommended by Volvo Penta. See the Instruction Manual. The use of inferior fuel can damage the engine. On a diesel engine the use of inferior fuel can lead to jamming of the control rod and over-revving of the engine, with the risk of both damage to the machine and personal injury. Inferior fuel can also lead to high maintenance costs.

General information

About the Workshop Manual

This Workshop Manual contains technical data, descriptions and repair instructions for the standard version of engine units TAMD61A, TAMD62A, TAMD63P-A, TAMD63L-A, TAMD71A, TAMD71B, TAMD72A, TAMD72WJ-A, and TAMD72P-A. The Workshop Manual shows the work procedure conducted on an optional engine as per the above specification, and therefore the illustrations and photographs of certain details may not fully correspond with other engines. The repair methods, however, remain the same in all their critical parts. If this should not be the case important differences will be reported separately. The engine designation and number is indicated on the rating plate (see Workshop Manual Group 21 Engine page 15). The engine designation and number should be stated on all correspondence concerning an engine.

The Workshop Manual is primarily produced for Volvo Penta service workshops and their qualified personnel. It is therefore assumed that persons using this manual have basic competence on marine drive systems and can conduct work of a mechanical/electrical nature attendant to this profession.

Volvo Penta continuously develops its products, and therefore we reserve the right to change technical specifications without prior notice. All information in this manual is based on product data available prior to press. Any modifications of critical importance introduced on the product or service methods after this date are confirmed in the form of Service Bulletins.

Spare parts

Spare parts for the electrical and fuel systems are subject to different national safety regulations, e.g. US Coast Guard Safety Regulations. Volvo Penta Genuine Parts comply with these regulations. All types of damage occurring as a result of the use of non genuine Volvo Penta parts for the product in question will not be regulated by the warranty undertakings of Volvo Penta.

Certified engines

For engines which are certified for national and regional environmental legislation the manufacturer undertakes to ensure compliance with environmental regulations both for new engines and those in use. The product must comply with the approved example on certification. In order for Volvo Penta as manufacturer to ensure that engines in use comply with the set environmental regulations the following requirements for service and spare parts must be fulfilled:

- Service intervals and maintenance procedures recommended by Volvo Penta must be followed.
- Only Volvo Penta Genuine Parts, intended for the certified engine version, must be used.
- Service which includes the ignition system, ignition adjustment and fuel injection system (petrol) or injection pumps, pump adjustment and injectors (diesel) shall always be conducted by an authorised Volvo Penta workshop.
- The engine must not be rebuilt or modified in any way, with the exception of the accessories and service sets which Volvo Penta has developed for the engine.
- Installation modifications on exhaust pipes and air intake channels for engine chambers (ventilation channels) must not be made, since this can influence exhaust emissions.
- Seals must not be broken by unauthorised personnel.



IMPORTANT! When spare parts are required use only Volvo Penta Genuine Parts.

The use of non genuine parts implies that AB Volvo Penta no longer assumes responsibility for the compliance of the engine with the certified version.

All types of damage or costs occurring as a result of the use of non genuine Volvo Penta parts for the product in question will not be regulated by Volvo Penta.

Repair instructions

The work methods described in the Workshop Manual are applicable for a workshop environment. The engine is therefore removed from the boat and mounted in an engine block. Renovation work which does not require removal of the engine is conducted in situ with the same work methods, unless otherwise stated.

The warning symbols used in the Workshop Manual (see Information on Safety for implication)



WARNING!



IMPORTANT!

NOTE!

These are in no way comprehensive, since we obviously cannot foresee everything, in that service work is conducted under the most various conditions. We can therefore only point out the risks which we consider can arise as a result of incorrect handling during work in a well-equipped workshop with work methods and tools which are proven by us.

In the Workshop Manual all the work procedures for which there are special Volvo Penta tools are conducted with these. The special tools are specially produced to facilitate the most safe and rational work method possible. It is therefore the responsibility of persons using other tools or another work method than that which we recommend to ensure that no risk of personal injury, material damage or malfunction can occur.

In some cases there may be special safety instructions and user instructions for the tools and chemicals named in the Workshop Manual. These instructions shall always be followed and there are no special instructions for this in the Workshop Manual.

By means of taking certain elementary procedures and using a modicum of common sense, most risk factors can be prevented. A clean workplace and a clean engine eliminate many risks both of personal injury and malfunction.

Especially during work on the fuel system, lubrication system, induction system, turbo, bearing unions and sealing unions, it is of the greatest importance that dirt or foreign particles do not get in, since this can result in malfunctioning or shorten the repair service-life.

Our joint responsibility

Each engine consists of a large number of interactive systems and components. The deviation of a component from the technical specification can dramatically increase the environmental impact from an otherwise first-rate engine. It is therefore of extreme importance to maintain the given wear tolerances, that systems capable of adjustment receive the correct setting, and that Volvo Penta Genuine Parts are used for the engine. The time intervals in the engine's maintenance schedule must be followed.

Certain systems, e.g. components in the fuel system, may require special competence and special test equipment. Certain components are sealed at the factory for environmental reasons. Work on sealed components must not be conducted unless authorisation for such work is held.

Remember that most chemical products, incorrectly used, are hazardous to the environment. Volvo Penta recommends the use of biologically decomposing degreasing agents for all cleaning of engine components, unless otherwise stated in the Workshop Manual. When working on board a boat pay special attention to make sure that oils and washing residue are handled correctly for destruction, and do not unintentionally end up in the nature, e.g. in the bilge-water.

Tightening torque

Tightening torque for vital unions, which should be tightened with dynamometric wrenches, is listed in "Specifications: Tightening torque" and indicated in the manual's work descriptions. All torque indications are applicable for cleaned threads, screw heads and mating surfaces. The torque indications refer to lightly oiled or dry threads. If lubricants, locking liquids or sealants are required for the screw union, the type is indicated in the work description and in "Tightening torques". General tightening torque as per the table below is applicable for unions where special torque indications are not given. The torque indication is a standard value and the union does not require tightening with a dynamometric wrench.

Size	Tightening torque	
	Nm	ft.lb
M5	6	4.4
M6	10	7.4
M8	25	18.4
M10	50	36.9
M12	80	59.0
M14	140	103.3

Angular tightening torque

For angular tightening torque the screw union is tightened with a given torque, thereafter further tightening with a predetermined angle. Example: at 90° angular tightening the union is tightened and an additional 1/4 turn is made in a work procedure after the given tightening torque has been reached.

Lock nuts

Dismantled lock nuts shall not be reused but replaced with new items, since the locking properties diminish or are lost with repeated use. For lock nuts with plastic inserts, e.g. Nylock®, the tightening torque given in the table shall be reduced if the Nylock® nut has the same nut height as a standard full-metal hexagonal nut. The tightening torque is reduced by 25% for screw size 8 mm or larger. For Nylock® nuts with higher nut heights, where the full-metal thread is equally high as a standard hexagonal nut, the tightening torque as per the table are applicable.

Strength classes

Screws and nuts are divided into different strength classes; affiliation is indicated by the marking on the screw head. A higher number on the marking represents a stronger material, e.g. a screw marked 10–9 has a higher strength than a screw marked 8–8. It is therefore important when dismantling screw unions that the screws are refitted in their original places. For replacement of screws see the Parts Catalogue to ensure that the correct version is obtained.

Sealants

A number of different sealants and locking liquids are used on the engine. The properties of the mediums differ, and they are intended for different union strengths, temperature ranges, resistance to oils and other chemicals, and for the different materials and column sizes in the engine.

In order to conduct satisfactory service work it is therefore important that the correct type of sealant and locking liquids are used for the unions where such are required.

In the Workshop Manual we have indicated in respective chapters the agents which are used in our engine production.

During service work the same agent, or agent with similar properties but of other manufacture, shall be used.

When using sealants and locking liquids it is important that the surfaces are free from oil, grease, paint and anti-rust agent, and that they are dry.

Always follow the instructions of the manufacturer concerning application temperature, hardening time and other instructions for the product.

Two different basic types of agents are used on the engine, and these are characterised by:

RTV-agent (Room temperature vulcanising). Most often used with gaskets, e.g. sealing of gasket joints or applied on gaskets. RTV-agent is fully visible when the part has been dismantled: old RTV-agent must be removed before the union is sealed again.

The following RTV-agents are named in the Workshop Manual: Loctite® 574, Volvo Penta 840879-1, Permatex®.

No. 3, Volvo Penta 1161099-5, Permatex® No. 77.

Old sealant is removed in each case with denatured spirit.

Anaerobic agents. These agents harden on the absence of air. The agent is used when two solid parts, e.g. cast components, are fitted together without gasket. A common application is also to secure and seal plugs, threads on pin bolts, taps, oil pressure relays, etc. Hardened anaerobic agents are transparent and therefore they are coloured to make them visible.

Hardened anaerobic agents are very resistant to solvents and old agent cannot be removed. Careful degreasing is conducted prior to refitting, and new sealant is applied.

The following anaerobic agents are named in the Workshop Manual: Loctite® 572 (white), Loctite® 241 (blue).

NOTE! Loctite® is a registered trade-mark for Loctite Corporation, Permatex® is a registered trade-mark for Permatex Corporation.

Safety instructions for fluorocarbon rubber

Fluorocarbon rubber is a common material used in seals for shafts and O-rings.

When fluorocarbon rubber is exposed to high temperatures (over 300° C) **hydrofluoric acid** can be formed, which is strongly corrosive. Contact with the skin can result in serious burn injuries. Contact with the eyes can result in malignant ulcers. Inhalation of fumes can injure the respiratory passages.



WARNING! Observe great care during work on engines which can have been exposed to high temperatures, e.g. overheating during seizing or fire. Seals must never be burned loose during dismantling or subsequently burned in an uncontrolled manner.

- Always wear gloves of chloroprene rubber (gloves for handling chemicals) and protective goggles.
- Handle the removed seal in the same way as corrosive acid. All residue, including ash, can be strongly corrosive. Never use compressed air to blow clean.
- Place the residue in a sealed plastic tin provided with a label. Gloves are washed under running water before taking them off.

The following seals are in all probability manufactured of fluorocarbon rubber:

Seals for crankshafts, camshafts, intermediate shafts.

O-rings irrespective of where they are fitted. O-rings for cylinder lining sealing are almost always of fluorocarbon rubber.

Note that seals which have not been exposed to high temperatures can be handled as normal.

Special tools

In all cases where it has been practically possible the tools have been stamped with a tool number, excluding the last digit. The last digit (after the hyphen) is a control number.

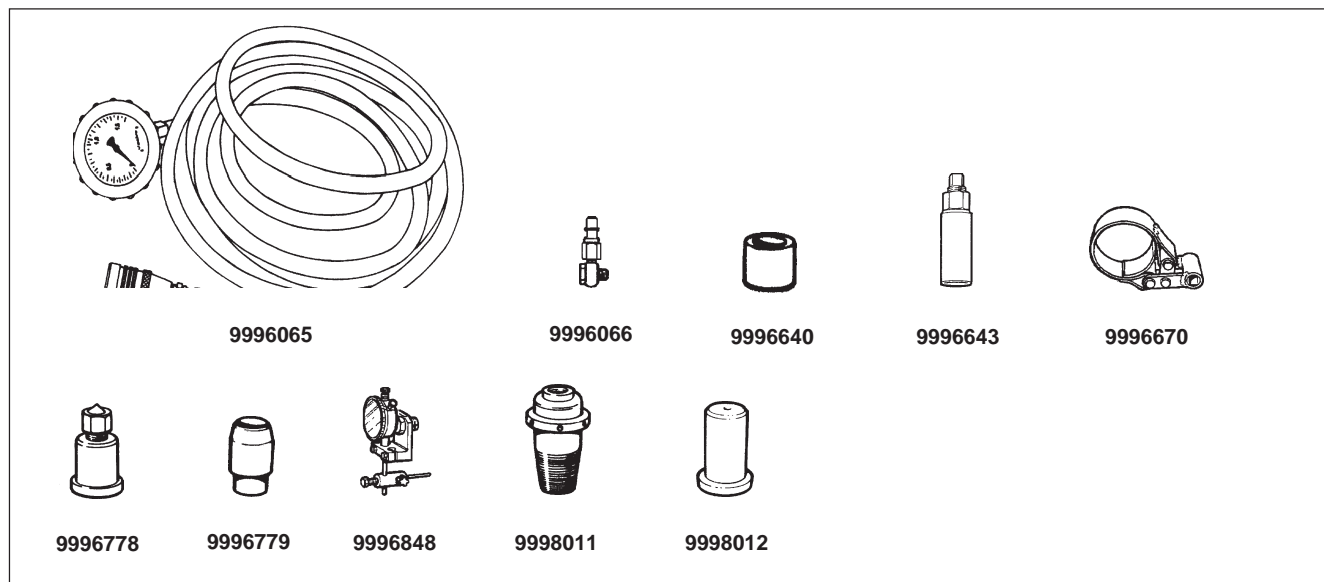

- | | | | |
|-----------|---|-----------|---|
| 9996065-0 | Pressure gauge for checking of charging pressure. | 9996779-6 | Extractor for seal in pump drive, TAMD61, -62, -71. |
| 9996066-8 | Nipple for checking of supply pressure. | 9996848-9 | Adjusting tool for injection pump. |
| 9996640-0 | Mandrel, used together with extractor 99968011. | 9998011-2 | Extractor for seal in pump drive, TAMD63, -72. |
| 9996643-4 | Extractor for injectors. | 9998012-0 | Mandrel for positioning of seal in pump drive, TAMD63, -72. |
| 9996670-7 | Filter key for fuel filter. | | |
| 9996778-8 | Tool for pressing in seal for pump drive, TAMD61, -62, -71. | | |

Other special equipment

- 9812546-1 Tap brush for cleaning of injector's copper sleeve.
- 9987057-8 Adjusting tool for fuel pump's injection angle.
- 9989876-9 Dial gauge 0.8 in.

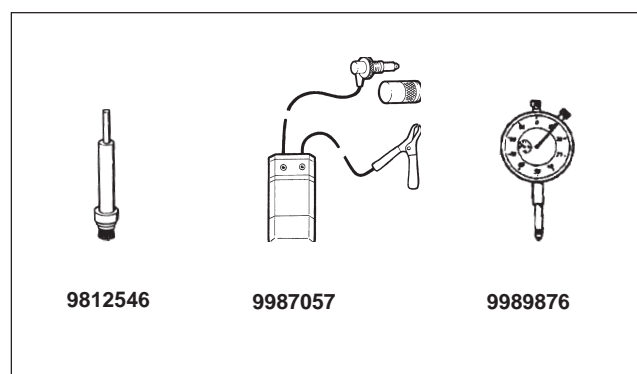

9812546

9987057

9989876

Design and function

General

The main parts of the fuel system are the fuel tank with fitting, feed pump, two fuel filters, injection pump, fuel injectors and pipelines.

The fuel is induced by the feed pump from the fuel tank and pressed through the fine filter to the injection pump. Excess fuel returns through the overflow valve (placed on the injection pump) back to the tank. This implies that return fuel flushes through (cools) the injection pump's fuel chamber. The temperature of the fuel is thus equalised (and becomes the same

for all the engine cylinders) while gas bubbles in the fuel are avoided.

The injection pump then presses at high pressure a fuel volume corresponding to the power requirement through the delivery pipe to the injectors, which atomises the fuel in the engine's combustion chambers.

Return fuel from the fuel injectors is led through the leak-off pipe via the overflow valve and return pipe back to the tank.

Note: Certain of the illustrations in this chapter have been kindly put at our disposal by Robert Bosch AB.

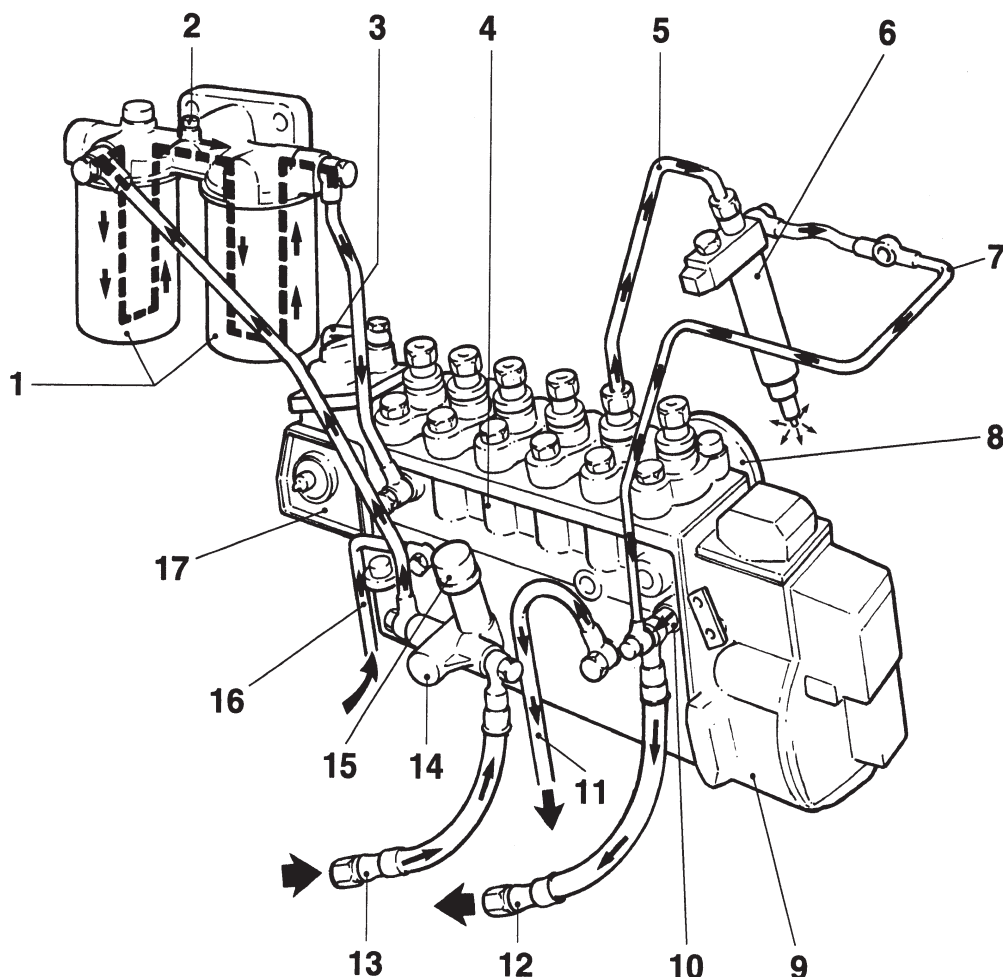

Fuel system

- | | |
|--|-----------------------------|
| 1 Fuel fine filter | 10 Overflow valve |
| 2 Venting screw | 11 Return pipe, lubricant |
| 3 Delivery pipe from intake pipe (charging pressure) | 12 Return pipe to fuel tank |
| 4 Injection pump | 13 Fuel pipe, intake |
| 5 Delivery pipe | 14 Feed pump |
| 6 Fuel injector | 15 Hand pump |
| 7 Leak-off pipe | 16 Lubricant pipe, intake |
| 8 Pressure equaliser | 17 Smoke limiter |
| 9 Centrifugal regulator | |

Injection pump

The injection pump is placed on the left-hand side of the engine and is driven from the timing gears. The pump, which is of the piston type, is equipped with 6 pump elements (6), one for each engine cylinder, which pump the fuel under high pressure to the engine's combustion chambers. Each pump element consists of piston and cylinder, where the piston is pressed up by the pump's camshaft (11) by means of a lifter (10), and pressed back by the piston spring (9).

The piston has a constant stroke length and is actuated by the regulator, via a control rod (7), which turns the piston during operation, whereby the injected fuel volume can be modified.

The injection pump is lubricated by means of the engine's lubricating system.

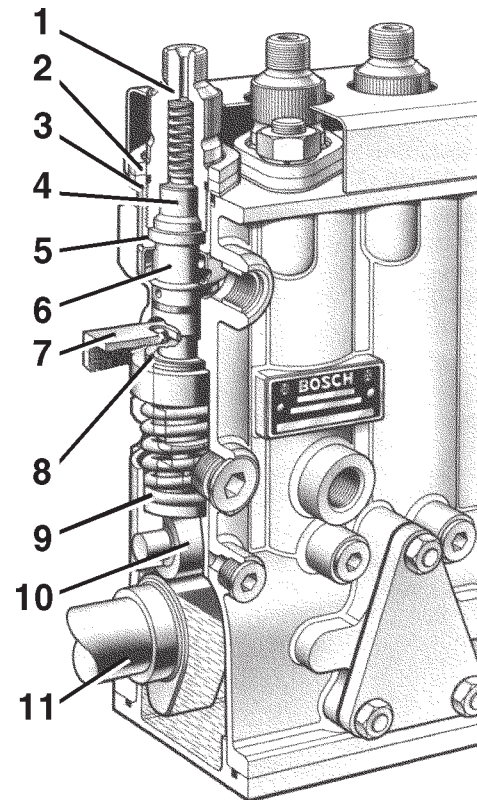

The pump element's pump function

- A. When the piston is in its lower position the pressure chamber over the piston is filled with fuel from the fuel pump.
- B. When the piston moves up in the cylinder the fuel supply is shut off. The fuel above the piston is compressed, the pressure increased, and the pressure valve (1) opens.
- C. When the piston has reached a certain height in its upward going movement the relief hole (2) is exposed (also designated inlet hole when the piston is in its lower position). The fuel flows back via the zero channel (3) and the piston's spiral shaped channel (4). The pressure above the piston reduces and the pressure valve (1) is closed. The excess fuel is returned back to the fuel tank.

Injection pump

- | | |
|---------------------------|------------------|
| 1 Delivery valve retainer | 7 Control rod |
| 2 Thrust plate | 8 Control sleeve |
| 3 Sealing ring | 9 Piston spring |
| 4 Delivery valve | 10 Lifter |
| 5 Flange bushing | 11 Camshaft |
| 6 Pump element | |

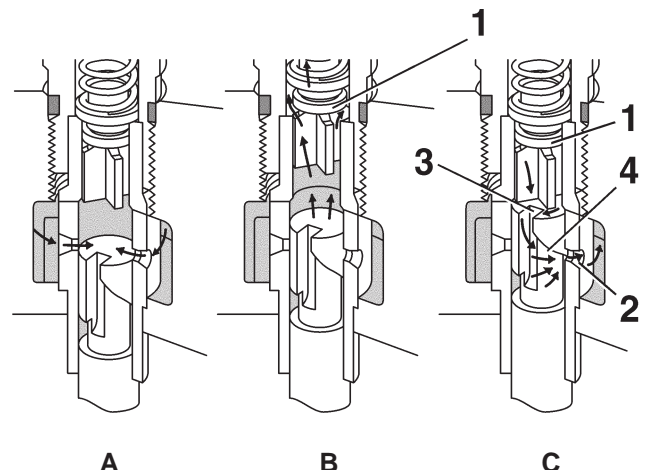

The pump element's pump and control function

The pump element's control function

The pump element's control function is controlled by the regulator, which via the control rod turns the pump piston. Depending on the position of the piston in the cylinder the length of the injection time and injection volume can vary in that the piston's spiral shaped channel (4) opens the connection with the relief hole. If the piston is turned so that the vertical

channel (3) (zero channel) on the pump piston comes opposite the relief hole (2) the fuel will flow back during the full piston stroke to the pump's fuel chamber and the engine will stop.

Regulator

The regulator has the purpose of controlling the fuel volume to the engine's combustion chambers by means of activating the throttle control.

The regulator is available in two versions:

- Centrifugal regulator which is mechanical and is used on engine versions TAMMD61A, -62A, -63P-A, -63L-A, -71A, -71B, -72A, and -72WJ-A.
- Electromagnetic actuator which is electronic and is used on the engine version TAMMD72P-A.

The mechanical regulator works with speed sensing regulator weights. The speed is controlled over the full speed range of the engine, from low idle to high idle.

The electromagnetic actuator is controlled from an electronic control unit which collects information from a number of sensors placed on the engine and control. The control unit calculates with the help of this information the injection volume for each load case.

The illustrations below show the differences between a mechanical regulator and an electromagnetic actuator.

Two different basic types of centrifugal regulator are used, RSV and RQV. The RQV regulator is available in two versions, RQV and RQV-L. The electromagnetic actuator is designated RE.

The main difference between RQV and RQV-K is that the RQV-K regulator can both increase and decrease the fuel volume during equalising at full load, while the RQV regulator's equalising only gives a reduction of the fuel volume.

The following list shows which regulator type is used for the different engine versions:

- TAMMD61A, -62A, -63L-A and -71A/B have a regulator of the RSV type.
- TAMMD 63-P-A has an RQV regulator.
- TAMMD72A and -72WJ-A have an RQV-K regulator.
- TAMMD72P-A (EDC) has an RE regulator.

Principle diagram of injection pump with Centrifugal regulator

- 1 Max. fuel volume
- 2 Min. fuel volume
- 3 Full throttle
- 4 Idle
- A Control rod
- B The injection pump's camshaft
- C Lever
- D Centrifugal regulator

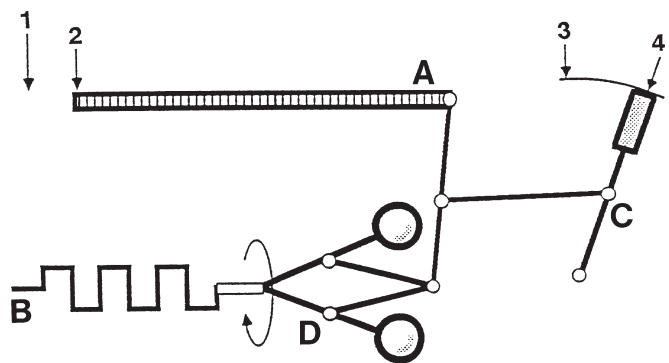

Principle diagram of injection pump with electromagnetic actuator

- 1 Max. fuel volume
- 2 Min. fuel volume
- 3 Full throttle
- 4 Idle
- 5 Position sensor for control rod
- 6 Actuator
- 7 Speed sensor
- A Control unit
- B Actuator

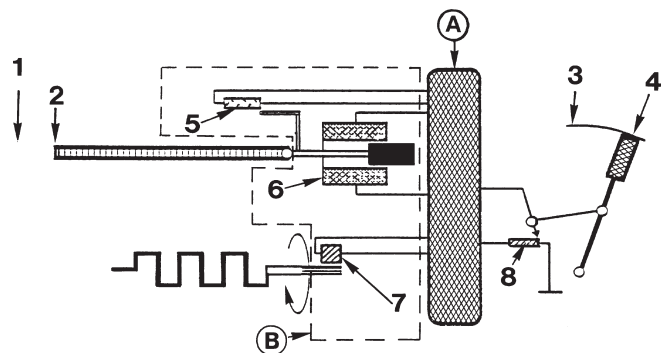

Centrifugal regulators RSV, RQV and RQV-K

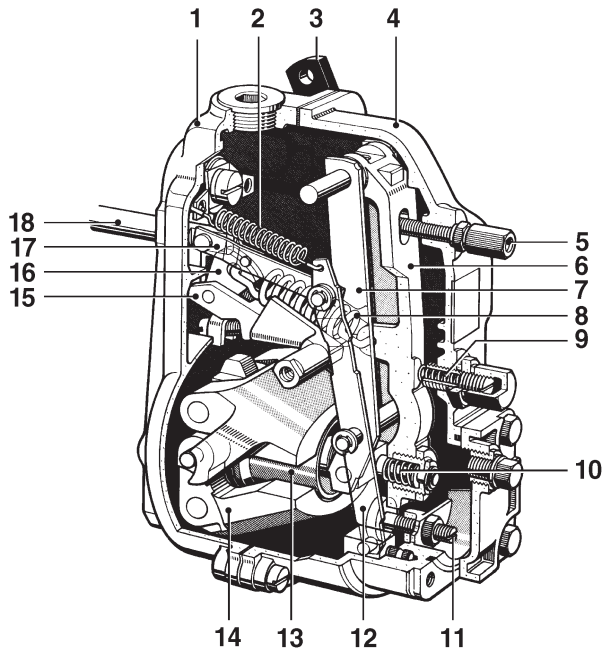

Centrifugal regulator, RSV

- 1 Regulator housing
- 2 Starter spring
- 3 Lever
- 4 Regulator cover
- 5 Set screw for stop and idle
- 6 Tensioning arm
- 7 Control arm
- 8 Regulator spring
- 9 Idle damping spring
- 10 Equalising or idle compression spring
- 11 Set screw for full-load stop
- 12 Regulator arm
- 13 Regulator sleeve
- 14 Centrifugal weight
- 15 Swivel arm
- 16 Rocker arm
- 17 Link rod
- 18 Injection pump's control rod

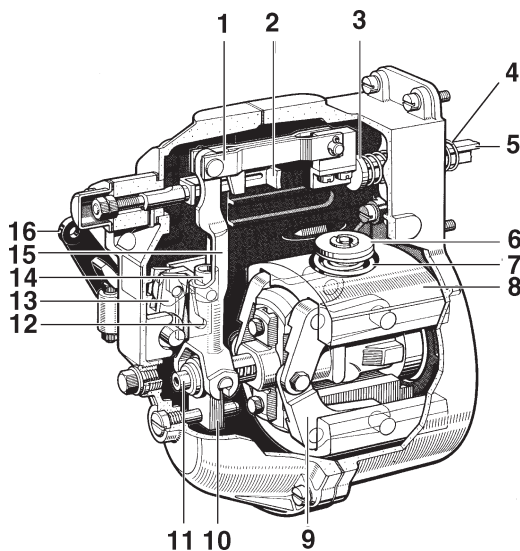

Centrifugal regulator, RQV

- 1 Link rod
- 2 Full-load stop
- 3 Spring disc
- 4 Play equalising spring
- 5 Injection pump's control rod
- 6 Adjusting nut
- 7 Regulator springs
- 8 Centrifugal weight
- 9 Angle arm
- 10 Compression ring
- 11 Spring control sleeve
- 12 Guide plate
- 13 Selector arm
- 14 Control piston
- 15 Regulator arm
- 16 Lever

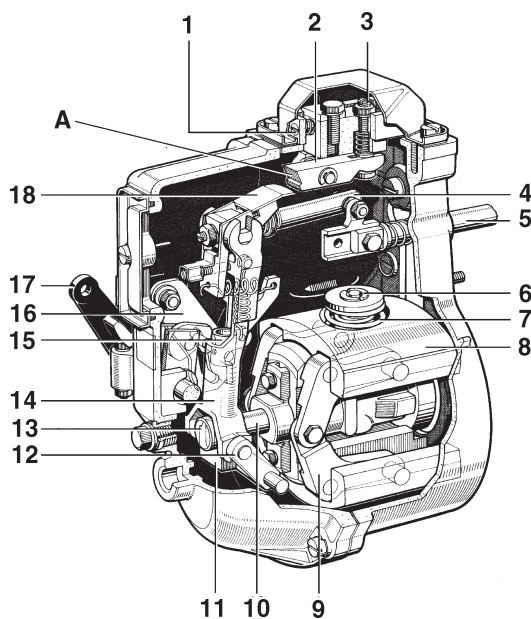

Centrifugal regulator, RQV-K

- 1 Adjusting screw for full-load volume
- 2 Full-load stop with cam track (A)
- 3 Set screw for curve path's angle modification
- 4 Link rod (springs when pulled)
- 5 Injection pump's control rod
- 6 Adjusting nut
- 7 Regulator springs
- 8 Centrifugal weight
- 9 Angle arm
- 10 Regulator sleeve
- 11 Compression ring
- 12 Control arm
- 13 Muff
- 14 Regulator arm
- 15 Control piston
- 16 Guide plate
- 17 Lever
- 18 Rocker arm

Design differences between RSV and RQV/RQV-K regulators

The basic difference in design between the regulator types RSV and RSQ is in the regulator part:

- The RSV regulator has an exterior regulator spring (8), the centrifugal force acts via an arm on the regulator spring.
- The RQV and RQV-K regulators have regulator springs (7) built into the centrifugal weights.

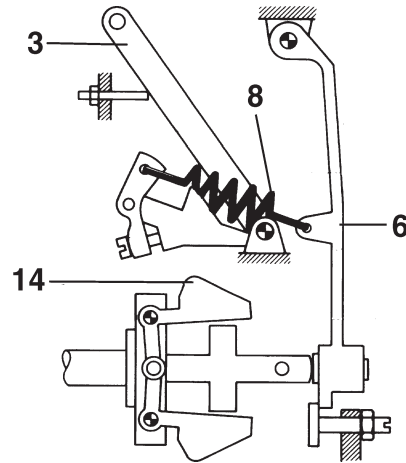

Principle diagram, regulator part RSV regulator*

Design differences between RQV and RQV-K regulators

RQV and RQV-K have the same basic design of the regulator part, with the regulator springs mounted in the centrifugal weights. The fundamental difference is the equalising of the fuel volume at full load.

The equalising of the fuel volume in RSV and RQV regulators gives a certain reduction of the fuel volume at full load and increasing speed, while the RQV-K regulator can both increase and decrease the full-load volume somewhat.

Equalising in the RQV-K regulator occurs in that a rocker arm (18) located on the upper end of the regulator arm (14) senses a guide path (A) on the full-load stop (2).

The guide path is adjusted to the engine's fuel requirement. The link rod (4), which links the regulator arm and control rod, transfers movement from the rocker arm to the injection pump's control rod (5).

A full-load volume is thereby achieved with corresponds to the required torsional moment.

* The position descriptions in the diagrams are given on respective regulators on the previous page.

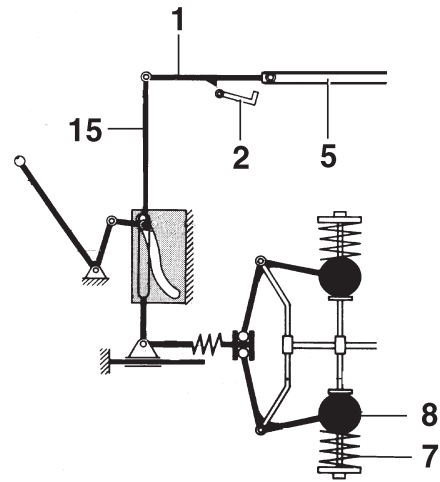

Principle diagram, regulator part RQV regulator*

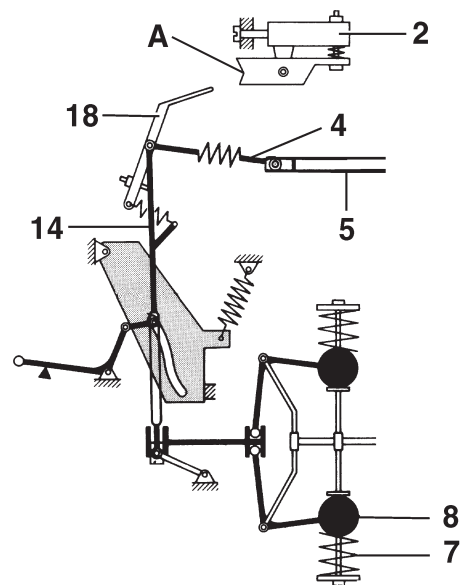

Principle diagram, regulator part RQV-K regulator*

Pressure variable full-load stop

All engines with the exception of TAMD72P-A* have as standard a pressure variable full-load stop (smoke limiter) placed on the front edge of the injection pump. Its purpose is to prevent exhaust fumes during rapid accelerations from low speed by means of limiting the control rod's stroke length (fuel volume) until the turbo compressor has received sufficient exhaust fumes to be able to give full air volume. The smoke limiter is connected with the intake pipe via a plastic tube.

* TAMD72P-A is not fitted with smoke limiter. The corresponding function is integrated in the EDC system.

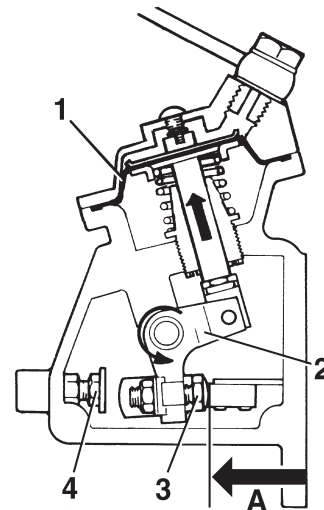

Low charging pressure, small full-load volume

Function: pressure variable full-load stop

The membrane (1) is actuated when there is a change in the pressure ratio in the intake pipe. The membrane movement is transferred by means of a link system to the angle lever (2), in the lower part of which an adjusting screw (3) for low max. volume is place.

The screw limits the movement of the control rod at low charging pressure (A). At high charging pressure the other end of the screw goes against the stop screw (4) for high max. volume (B).

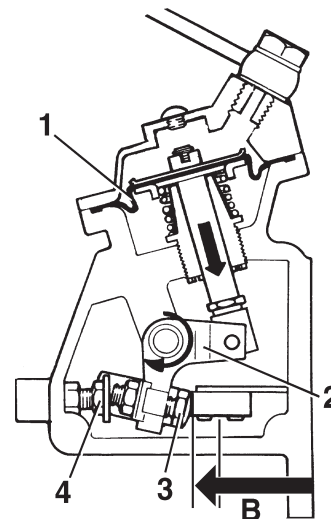

High charging pressure, large full-load volume

Feed pump

In order for the injection pump to function it has to be supplied with fuel at a certain pressure. This function is managed by a feed pump which is placed on the injection pump. The feed pump, which is of the piston type, is driven via the injection pump's camshaft.

The feed pump is equipped with a hand pump which can be used on an idle engine to pump fuel to the filter and injection pump.

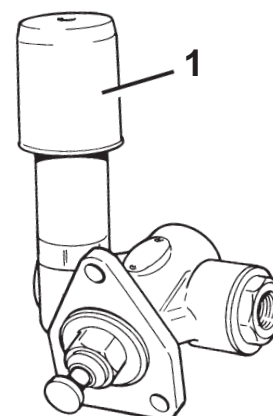

Feed pump

1 Hand pump

Overflow valve

The overflow valve, which is placed on the injection pump, should both limit the feed pressure and provide continuous venting of the fuel system.

When the feed pressure is too high the valve opens and fuel passes through the return line back to the tank. The overflow valve peg and spring can be dismantled and replaced if necessary.

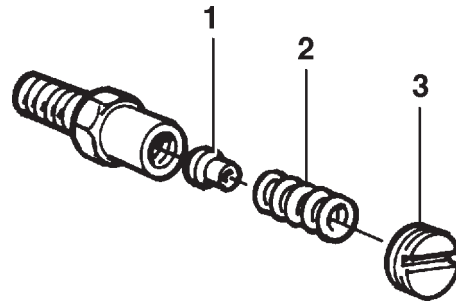

Overflow valve

- 1 Valve peg
- 2 Spring
- 3 Plug

Fuel injector

The fuel injectors are of the KBEL type, and each fuel injector consists primarily of a nozzle retainer and a nozzle.

The purpose of the fuel injector is to:

- Atomise the fuel to ensure ignition and combustion.
- Mix the fuel jets with the air turbulence in the combustion chamber to give an optimum mixture of fuel and air.

Function of the fuel injector

When the fuel pressure has increased to the set valve (opening pressure) the nozzle needle (10) lifts, which is held pressed against its seat by the compression spring (5).

Fuel is injected into the engine through precisely calibrated holes in the nozzle sleeve. For the number of nozzle holes and hole diameters refer to the Workshop Manual, Technical Data.

The opening pressure of the fuel injector is determined by the tension of the compression spring, which can be adjusted with adjusting washers (4).

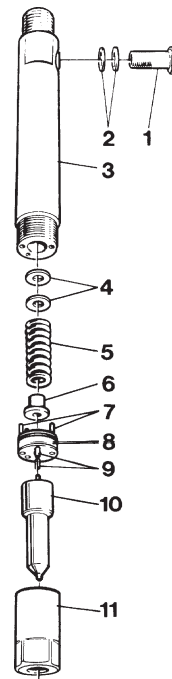

Fuel injector

- 1 Hollow screw
- 2 Gaskets
- 3 Nozzle retainer
- 4 Adjusting washers for setting of opening pressure
- 5 Compression spring
- 6 Thrust pin
- 7 Locating pins
- 8 Guide
- 9 Locating pins
- 10 Nozzle needle
- 11 Nozzle nut

Fuel shut-off valve (TAMD63, TAMD71B*, TAMD72WJ-A*)

The fuel shut-off valve consists of a solenoid valve which on activation changes the direction of flow in the fuel system.

The two flow diagrams show the fuel flow for inactive valve (A) and activated valve (B).

During operation the solenoid valve is inactive and the fuel has a similar direction of flow as in a system with a stop solenoid.

* as from engine no. 207181084/xxxx.

Function of the fuel shut-off valve

During operation the feed pump (4) induces fuel from the tank (3) via the pre-filter (6). From the pump the fuel is then pressed through the fuel filter (5) and the solenoid valve (2) to the injection pump (1).

When the key switch is moved to stop position the solenoid valve (2) is activated and the valve switches the direction of flow of the fuel. The fuel flow from the tank is blocked and the feed pump becomes connected on the injection pump's delivery fuel line.

The feed pump builds up an underpressure of approx. 4.3–5.8 psi in the injection pump, which implies that the pump element cannot be filled with fuel (the pump element requires overpressure for filling).

The injection pump is thereby emptied of fuel and the engine stops.

The non return valve (7) prevents fuel reaching the injection pump via the return line.

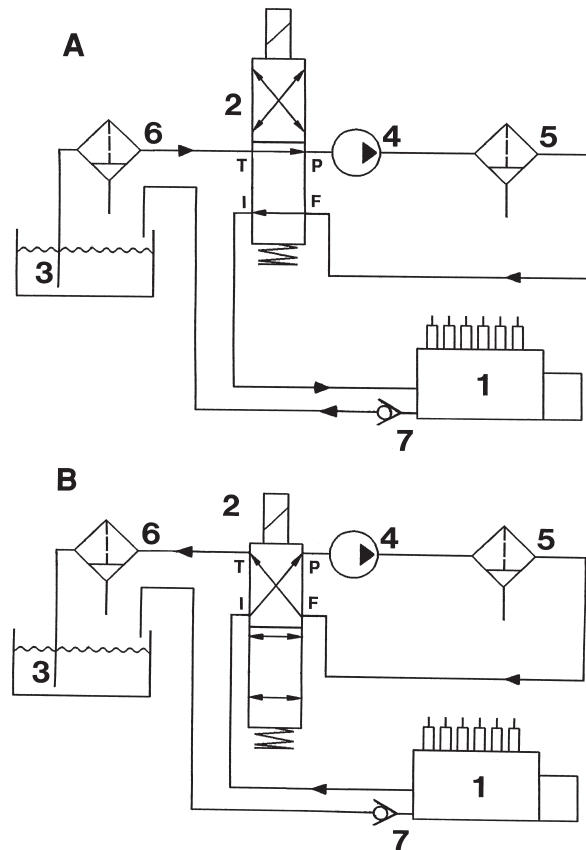

Flow diagram for fuel system with fuel shut-off valve

- A Engine running (solenoid valve not activated)
- B Stop function activated (solenoid valve activated)
- 1 Injection pump
- 2 Solenoid valve
- 3 Tank
- 4 Feed pump
- 5 Fuel filter
- 6 Pre-filter
- 7 Non return valve

Fuel filter

The fuel system is provided with two fuel filters connected in parallel with a joint cover.

The fuel filters are of the disposal type and the filter inserts consist of a spiral-wound paper filter. The diagram shows the path of the fuel through the filters.

As an accessory the fuel system can be fitted with a single or double (connected in parallel) water separating pre-filter. The double pre-filter permits changing the filter during operation.

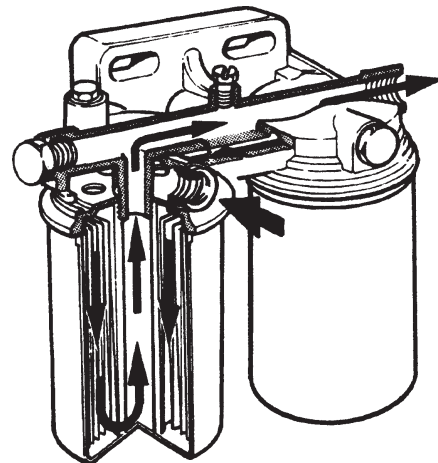

Path of the fuel through the fuel system's fine filter

Repair instructions

Instructions for work on the fuel system

Observe the greatest possible cleanliness when working with the fuel system. Before any component is dismantled, e.g. fuel pipe, the engine should be washed. Fit protective caps on all connections so that no dirt can penetrate. Inspection of the different component parts should always be conducted in a special room separated from other engine servicing.

Certain work, e.g. checking of fuel injectors, requires special equipment and training. In the event that this is lacking such work should be transferred to authorised diesel workshops.

In the event of a suspected loss of engine power factors such as bottom cleanliness, propeller selection, boat load and load distribution, should be checked before work with adjusting the pump is started.

NOTE! For environmental reasons certain adjustments are sealed. Work which requires breaking sealed components should only be conducted by authorised diesel workshops and their specially trained personnel.

All engine warranties become invalid if seals have been broken by unauthorised personnel. On completion of work the component shall be resealed with the seals for this purpose (BOSCH or VOLVO PENTA), so that the authorisation number (marking tong's number) is clearly visible.

Injection pump, removal

Note: All fuel and oil pipes including connections shall be provided with protective plugs when connections are taken apart.

This work method applies for all engines presented in this Workshop Manual.

To distinguish between work procedures which are only applicable for some engines the text, e.g.

Only applicable for TAMD72P-A, is used.

1

Clean the injection pump, piping and engine in the vicinity of the pump.

2

Does not apply to TAMD72P-A

Remove the throttle and stop controls.

3

Remove the fuel delivery pipes and plug the connections.

Note: The pipes are clamped together. Do not loosen the clamps, but remove the pipes together.

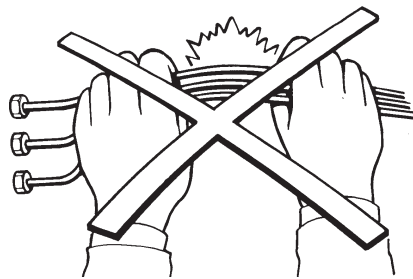

Only applicable for TAMD63 and TAMD72



WARNING! TAMD63 and TAMD72 have pretensioned fuel delivery pipes. The pipes must not under any circumstances be bent or re-bent. If a pretension pipe becomes bent or deformed there is a considerable risk that the pipe will break. A damaged pipe must always be replaced. When removing fuel injectors or injection pumps the complete pipe unit must be removed. Do not loosen the pipe unit's clamps to dismantle the separate pipes, but remove three-and-three pipes together.

4

Not applicable for TAMD72P-A

Remove the pipe to the smoke limiter.

5

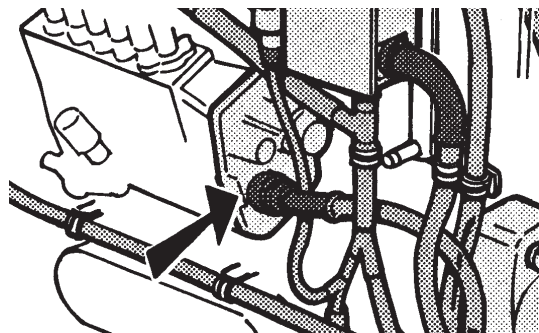

Only applicable for TAMD72P-A

Remove the contact connection to the injection pump's actuator.

Note: Protect the connection from fouling.

6

Only applies to TAMD63P-A, -63L-A, -71B*, -72WJ-A*

Remove the pipe to the fuel shut-off valve from the injection pump and feed pump.

Remove the pressure equaliser.

Remove the pipe to the fuel filter from the feed pump.

7

Does not apply to TAMD63P-A, -63L-A, -71B*, -72WJ-A*

Remove the pipe to the fuel filter from the injection pump and feed pump.

Remove the fuel feed pipe from feed pump.

8

Remove the oil delivery pipe and return oil pipe from the injection pump.

9

Remove the leak-off pipe from the fuel injectors.

10

Remove the leak-off pipe and return fuel pipe from the overflow valve.

* Applies to engines with fuel shut-off valves

11

Remove the pressure equaliser from the injection pump.

12

Remove the protective plate over the pump coupling.

13

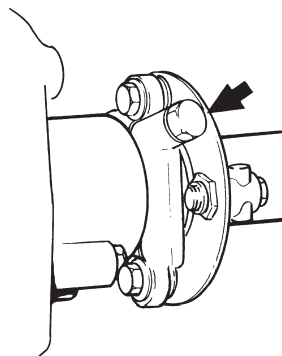

Release the clamping screw on the pump coupling

13

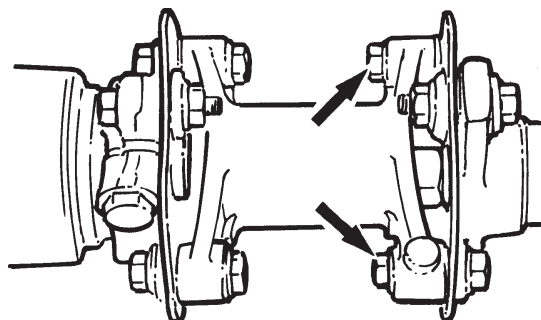

Remove the screws and sleeves between the pump coupling and injection pump's carrier.

14

Dismantle the pump's 4 attachment screws and lift off the pump.

NOTE! Observe care so that the steel ribs are not damaged!

Send the pump to an authorised diesel workshop (Bosch) for inspection if the workshop does not have specially trained personnel with the necessary testing equipment.

Injection pump, installation and adjustment

TAMD61/62*, TAMD71/72*

* Not applicable for TAMD63P-A which is equipped with stroke position sensor, and TAMD72P-A.

Special tools: 9989876, 9996848.

1

Check that the pump is in good order, and if necessary tested and approved, before it is fitted. Fill approx. 0.1 gallons of engine oil through the hole where the oil delivery pipe for lubricating of the pump is to be fitted (RSV regulator).

Do not remove the protective plugs before the pipes are connected.

Use new copper washers.

2

Carefully lift the pump in position. Insert and tighten the pump's attachment screws. See the Workshop Manual "Technical Data" page 23 for tightening torque.

3

Only applicable for TAMD71/72

Fit the pressure equaliser on the injection pump.

4

Check that the pump coupling is undamaged, well cleaned, and completely free from oil and impurities.

5

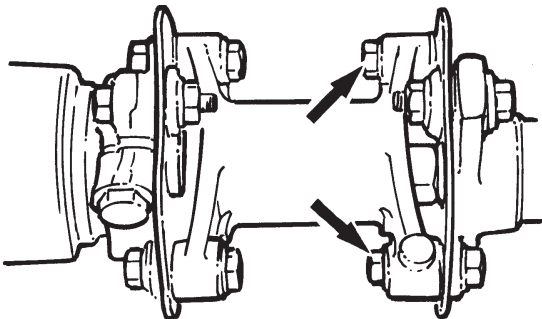

Fit the pump coupling together with the injection pump's carrier and tighten the nuts. See the Workshop Manual "Technical Data" page 23 for tightening torque.

NOTE! Do not tighten the clamping screw.

6

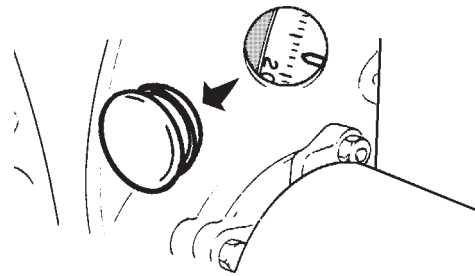

Remove the front valve cover. Remove the rubber plug to the flywheel cover's inspection hole.

7

Turn the engine round in its normal direction of rotation until the valves on the 1st cylinder are closed (compression stroke).

8

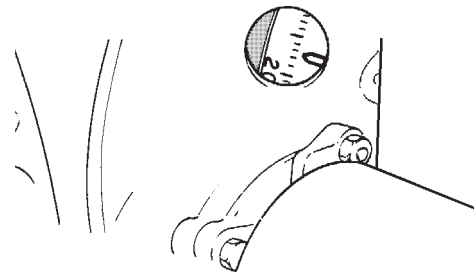

Turn the flywheel 1/4 of a turn in the opposite direction to the engine's direction of rotation. Thereafter turn in the engine's direction of rotation until the flywheel's degree setting is opposite the pointer in the flywheel cover. For the degree setting see the Workshop Manual "Technical Data" on pages 16 and 17.

Make a precise setting and do not turn the flywheel in the opposite direction of rotation to fine-adjust the setting.

If the flywheel has been turned too far the adjustment must be made from the beginning.

Note: Make sure that the line from the mark on flywheel over the pointer is at right-angles to the eye out from the flywheel. An error of several degrees can occur if the markings are looked at from the side.

9

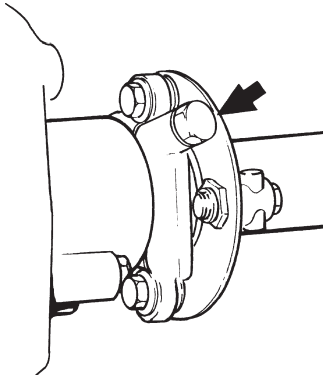

Tighten the pump coupling's clamping screw, but no more than that the coupling can turn freely on the shaft.

10

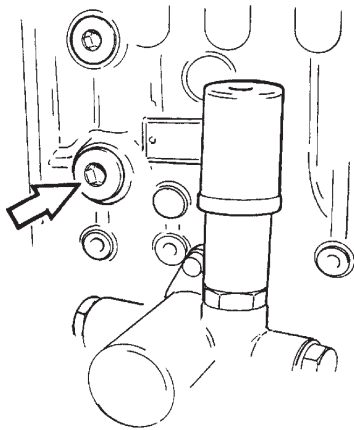

Remove the hex. socket plug and washer so that the 1st lifter on the injection pump is visible.

11

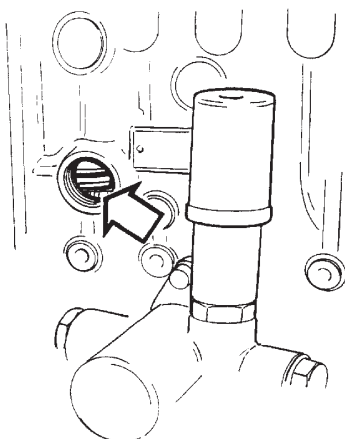

Turn back the pump coupling with a pair of tongs approx. 1/4 of a turn until the lifter is in its bottom position.

Note: Make sure that the pump coupling is not damaged.

12

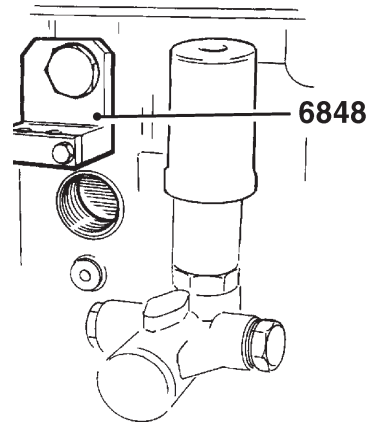

Place tool 9996848 on the injection pump.

13

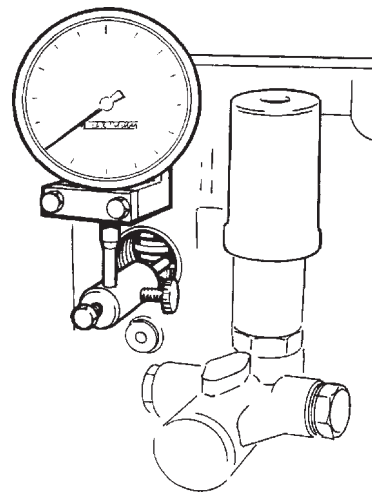

Put dial gauge 9989876 on 9996848.

14

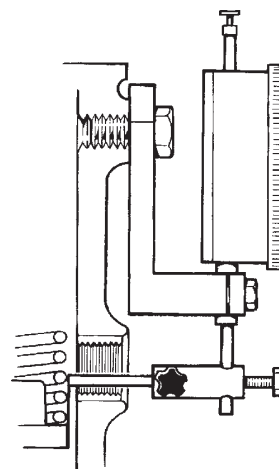

Adjust the tip of the needle so that it is flush with the lifter. Set the dial gauge to zero.

15

Turn round the pump coupling with a pair of tongs in the direction of rotation of the pump.

Check that the zero setting on the dial gauge is retained when the turn is made.

16

Continue to turn the pump coupling in the direction of rotation of the pump until the value for the lift from the basic circle (stroke position) is reached on the dial gauge. The value "lift from basic circle" (is given in the Workshop Manual "Technical Data" on pages 16 and 17.

17

Turn back the pump coupling in the opposite direction to the direction of rotation to the given value for the lift from basic circle.

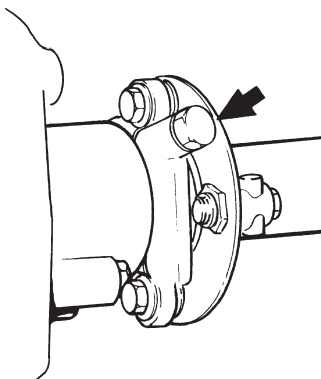

18

Tighten the pump coupling's clamping screw to the specified tightening torque.

19

Check the setting by rotating the flywheel against the direction of rotation of the engine, a 1/4 turn as in item 8.

Then turn the flywheel in the direction of rotation of the engine until the correct value of lift from the basic circle is shown on the dial gauge.

Read off the degree marking on the flywheel and check that it corresponds with the value in the Workshop Manual "Technical Data" on pages 16 and 17.

Note: Make sure that the line from the mark on the flywheel over the pointer to the eye is at right-angles from the flywheel. An error of several degrees can occur if the markings are looked at from the side.

20

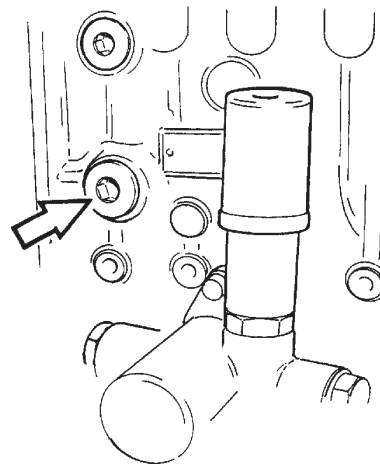

Remove the dial gauge and fixture 9996848 and replace the hex. socket plug with a new copper washer.

21

Fit the front valve cover, and if necessary replace the gasket. Put on the inspection cover/rubber plug at the flywheel cover.

22

Put on the leak-off fuel pipe on the fuel injectors with new copper washers.

23

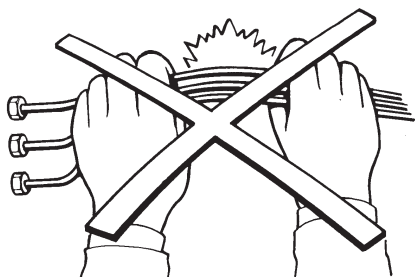

Put on the fuel delivery pipes.

NOTE! The fuel delivery pipes must under no circumstances be bent or re-bent. A damaged fuel delivery pipe must be replaced.

Fuel delivery pipes from TAMD61/62/71 must not be used on TAMD63/72.

24

Only applies to TAMD63P-A, -63L-A, -71B*, -72WJ-A*

Put on the pipes to the fuel shut-off valves from the injection pump and feed pump.

Put on the pressure equaliser.

Put on the pipe from fuel filter to the feed pump.

25

Does not apply to TAMD63P-A, -63L-A, -71B*, -72WJ-A*

Put on the pipes from the fuel filters on the injection pump and feed pump.

Put the fuel pipe on the feed pump.

Note: On TAMD61/62 the pressure equaliser must also be fitted on the hollow screw.

26

Put on the pipe to the smoke limiter.

27

Put on the leak-off pipe and return fuel pipe on the overflow valve.

28

Put on the oil delivery pipe and return pipe.

* Applies to engines with fuel shut-off valves

29

Fit the protective plate over the pump coupling.

30

Vent the fuel system.

31

Put on the throttle lever and stop lever.

32

Start the engine and check for leakage.

Injection pump, installation and adjustment

TAMD63P-A*, TAMD72P-A

* Not applicable for TAMD63P-A which does not have stroke position sensor.

Special tools: 9987057

1

Check that the pump is in good order, and if necessary tested and approved, before it is fitted. Fill approx. 0.1 gallons of engine oil through the hole where the oil delivery pipe for lubricating of the pump is to be fitted.

Do not remove the protective plugs before the pipes are connected.

Use new copper washers.

2

Carefully lift the pump in position. Insert and tighten the pump's attachment screws. See the Workshop Manual "Technical Data" page 23 for tightening torque.

3

Only applicable for TAMD72P-A

Fit the pressure equaliser on the injection pump.

4

Check that the pump coupling is undamaged, well cleaned, and completely free from oil and impurities.

5

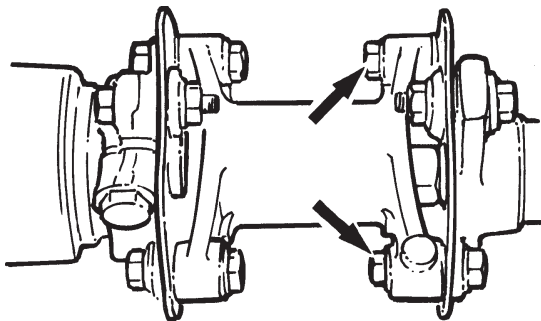

Fit the pump coupling together with the injection pump's carrier and tighten the nuts. See the Workshop Manual "Technical Data" page 23 for tightening torque.

NOTE! Do not tighten the clamping screw.

6

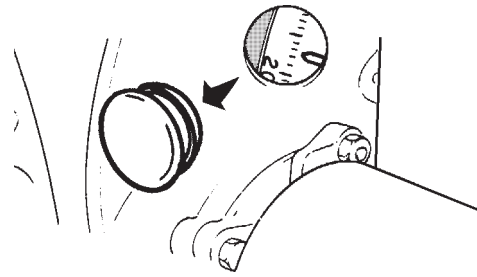

Remove the front valve cover. Remove the rubber plug to the flywheel cover's inspection hole.

7

Turn the engine round in its normal direction of rotation until the valves on the 1st cylinder are closed (compression stroke).

8

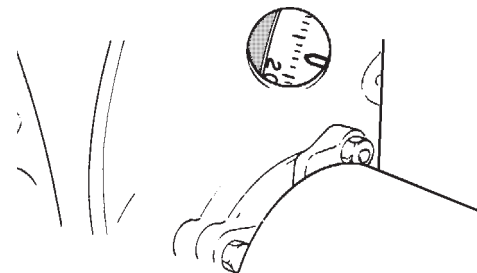

Turn the flywheel 1/4 of a turn in the opposite direction to the engine's direction of rotation. Thereafter turn in the engine's direction of rotation until the flywheel's degree setting is opposite the pointer in the flywheel cover. For the degree setting see the Workshop Manual "Technical Data" on pages 16 and 17.

Make a precise setting and do not turn the flywheel in the opposite direction of rotation to fine-adjust the setting.

If the flywheel has been turned too far the adjustment must be made from the beginning.

Note: Make sure that the line from the mark on flywheel over the pointer is at right-angles to the eye out from the flywheel. An error of several degrees can occur if the markings are looked at from the side.

9

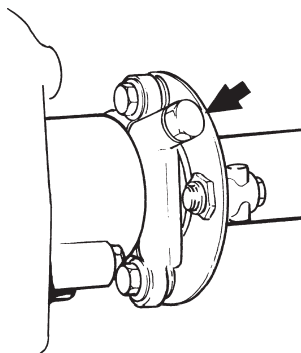

Tighten the pump coupling's clamping screw, but no more than tht the coupling can turn freely on the shaft.

10

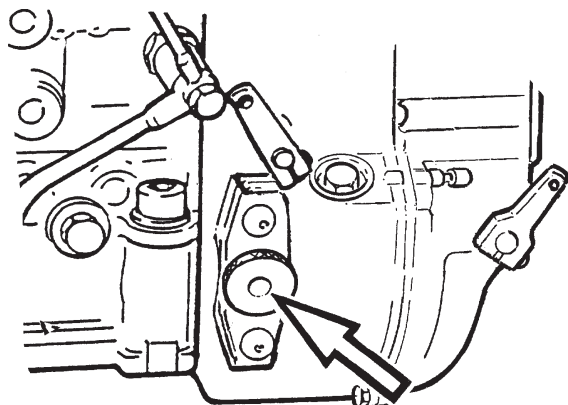

Remove the plug from the pump's regulator housing.

11

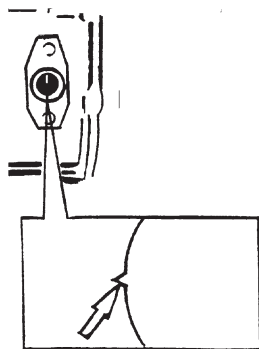

Turn the engine in the direction of rotation until the stroke position indicator becomes visible in the plug hole in the regulator housing.

12

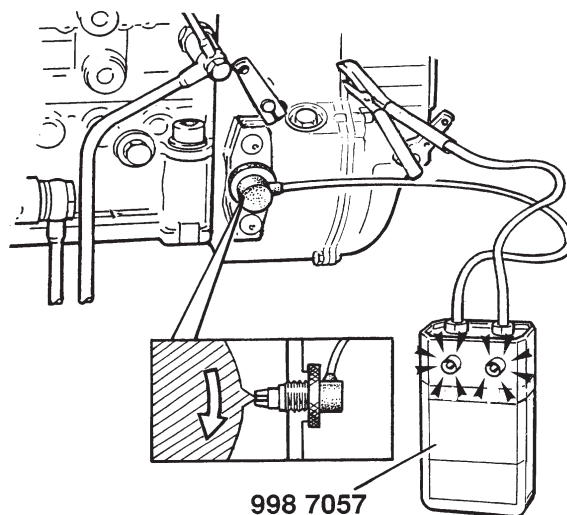

Place adjusting tool for the stroke position sensor 9987057 in the regulator housing's plug hole and connect the tool.

Turn the pump coupling until **both** the lamps on the tool go on, which implies that the stroke position sensor is between the two spring taps on the tool.

Note: When both lamps on the tool 9987057 go on and the engine has the 1st cylinder in the compression stroke, and when the flywheel shows the degree setting indicated in the Workshop Manual "Technical Date" on pages 16 and 17, then the engine is correctly adjusted.

13

If necessary adjust the pump by means of loosening the clamping screw.

After adjusting the clamping screw is tightened with the tightening torque indicated in the Workshop Manual "Technical Data" on page 23.

21

Fit the front valve cover, and if necessary replace the gasket. Put on the inspection cover/rubber plug at the flywheel cover.

Insert the plug in the regulator housing.

22

Put on the leak-off fuel pipe on the fuel injectors with new copper washers.

23

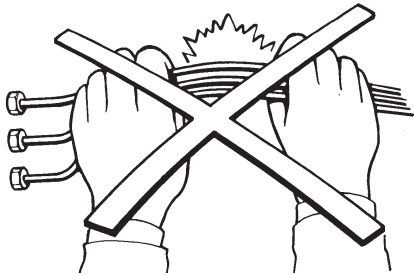

Put on the fuel delivery pipes.

NOTE! The fuel delivery pipes must under no circumstances be bent or re-bent. A damaged fuel delivery pipe must be replaced.

Fuel delivery pipes from TAMD61/62/71 must not be used on TAMD63/72.

24

Only applicable for TAMD63P-A

Put on the pipes to the fuel shut-off valves from the injection pump and feed pump.

Put on the pressure equaliser.

Put on the pipe from fuel filter to the feed pump.

25

Only applicable for TAMD72P-A

Put on the pipes from the fuel filters on the injection pump and feed pump.

Put on the fuel feed pipe on the feed pump.

26

Not applicable for TAMD72P-A

Put on the pipe to the smoke limiter.

27

Only applicable for TAMD72P-A

Put on the contact connection to the injection pump's actuator.

28

Put on the leak-off pipe and return fuel pipe on the overflow valve.

29

Fit the protective plate over the pump coupling.

30

Put on the oil delivery pipe and return pipe.

31

Refill with a volume of engine oil corresponding to the volume which ran out when the plug for the measuring instrument was removed.

32

Vent the fuel system.

33

Not applicable for TAMD72P-A

Put on the throttle lever and stop lever.

34

Start the engine and check for leakage.

Idle speed, adjustment

Not applicable for TAMD72P-A*

The engine should have a normal working temperature.

Check that the throttle control functions normally, i.e. that the injection pump's lever goes against the low idle stop when the throttle control is moved to idle position and pressed against the max. stop when the control is moved to max. position.

Adjust the control if necessary.

Check that the air filter is not blocked.

After adjusting the idle speed, sealed adjusting screws which have been broken shall be sealed again.

* For engine settings for TAMD72P-A, see Service Manual "Fuel system EDC" Page 26.

Adjustment of speed, RSV regulator

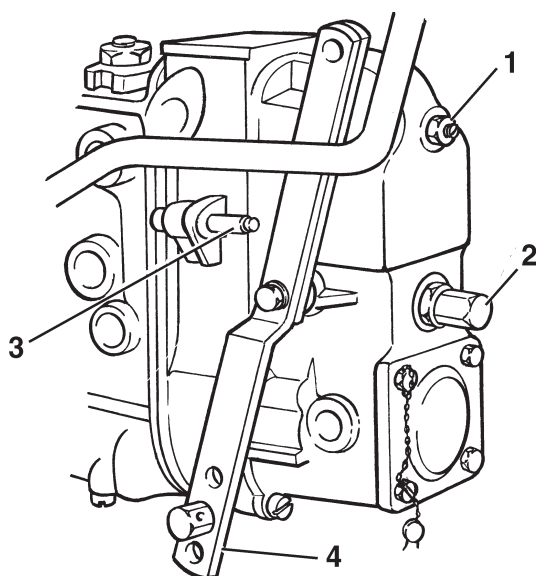

- 1 Adjusting screw for low idle speed
- 2 Adjusting screw, idle stabilising
- 3 Stop screw for high idle speed (sealed)
- 4 Lever

Low idle

1

Run the engine warm.

2

Run the engine at low idle speed and check the speed. See "Adjustment data" Service Bulletin Group 24-1 for speed.

3

Adjust the speed if necessary by removing the cap nut and screwing the adjusting screw (1) out or in.

If hunting occurs the idle damping should be adjusted as follows:

4

Remove the cap nut (2), release the lock nut, and turn the damping screw carefully clockwise while observing the speed.

5

Check that the high idle speed has not changed. If so the damping screw has been screwed in too far.

6

Lock the adjustment screw and screw the domed nut on after adjustment.

High idle

The stop for the max. speed is sealed. The seal must only be broken by an authorised diesel workshop.

7

Run the engine warm.

8

Run the engine unloaded at the maximum speed. Check that the lever goes against the stop screw (3) for the max. speed.

9

Check the speed with a tachometer. Adjust if necessary the stop (3) so that the correct speed is obtained. For engine speed, see "Setting data", Service Bulletin Group 24-1.

10

Seal the screw so that the authorisation number (marking tong number) is clearly visible.

Adjustment of speed, RQV regulator

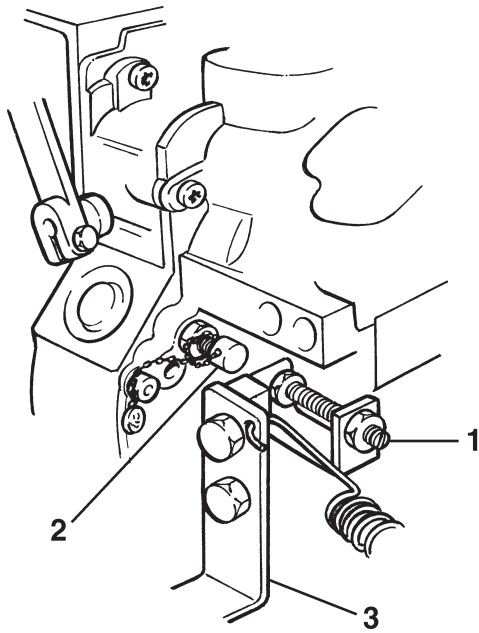

Adjustment of speed, RQV regulator

- 1 Stop screw for low idle speed
- 2 Stop screw for high idle speed (sealed)
- 3 Lever

Low idle

1

Run the engine at low idle and check that the low idle speed lies within the tolerances; see "Adjustment data" in Service Bulletins Group 24-1.

2

If necessary adjust the speed with the stop screw for the low idle speed (1).

High idle speed

1

Run the engine at max. speed a few seconds without load.

Check that the high idle speed lies within the tolerances; see "Adjustment data" in Service Bulletins Group 24-1.

2

If necessary adjust the speed with the stop screw the high idle speed (2). If the speed requires adjusting the adjusting screw must be sealed on completion of the adjustment.

Feed pump, replacement

1

Wash clean round the pump.

2

Close the fuel cocks and release the fuel pipes from the pump.

3

Dismantle the feed pump from the injection pump.

4

Clean the feed pump's mating surface on the injection pump and put on a new gasket.

5

Put on and screw tight the feed pump.

6

If lubricant has run out of the injection pump a corresponding volume should be refilled.

Remove the screw union for the oil delivery pipe and refill with oil through the hole.

7

Vent the fuel system.

8

Start the engine and check for leakage.

Feed pump, renovation

Pump removed

Dismantling

1

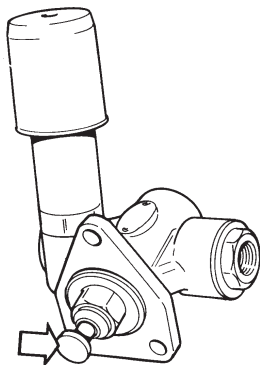

Remove the pull rod. Screw tight the pump in a vice with protected jaws.

2

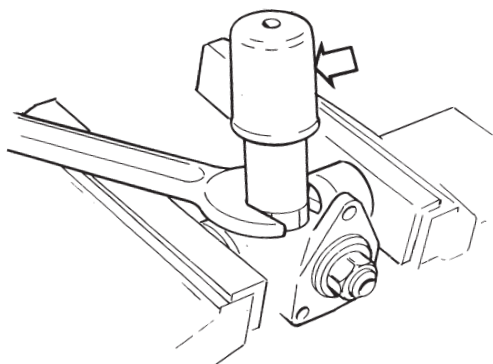

Unscrew the hand pump.

3

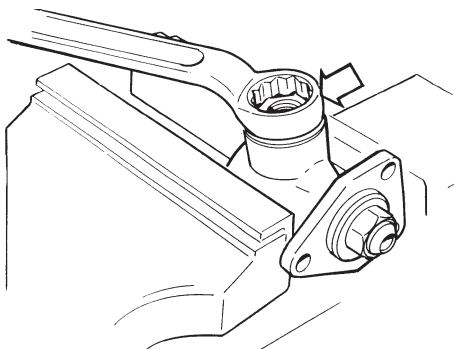

Remove the pump's inlet and outlet screw unions.

4

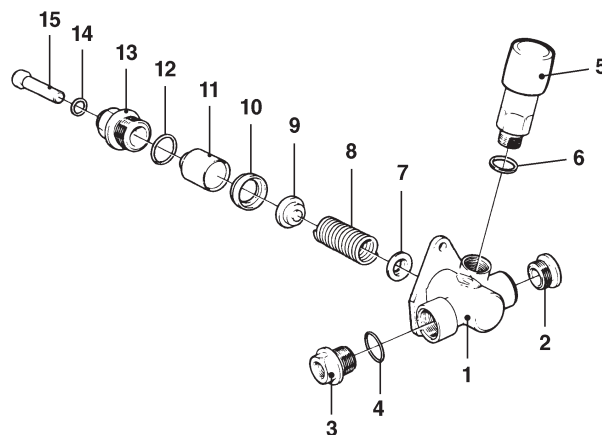

Feed pump

- | | |
|----------------------|----------------|
| 1 Pump housing | 9 Valve |
| 2 Screw union | 10 Spacer ring |
| 3 Screw union | 11 Pump piston |
| 4 O-ring | 12 O-ring |
| 5 Hand pump | 13 Screw union |
| 6 Gasket | 14 O-ring |
| 7 Spring disc | 15 Pull rod |
| 8 Compression spring | |

Remove the screw union (13).
Remove the pump piston (2), spacer ring (10), valve (9), and compression spring (8) with spring disc (7).
Wash all parts in pure diesel oil.

Inspection

Check the sealing of the piston in the bore, and the compression spring tension. Investigate other components and replace those which are damaged or worn.

Assembly

Observe the greatest cleanliness and rinse the parts in pure diesel oil before assembly.

5

Put the spacer ring (10) in the pump piston (11).

6

Put the valve (9), spring disc (7) and compression spring (8) in the pump piston (11).

7

Place the pump piston in the pump housing.

8

Fit the screw union (13) with the O-ring (12).

9

Fit the screw union (3) with the O-ring (4).

10

Fit the hand pump (5) with the gasket (6).

11

Put the O-ring (14) on the pull rod (15) and place the pull rod in the screw union (13).

Fit protective plugs for the connections if the pump is not to be fitted on the injection pump immediately.

Fuel delivery pressure, inspection

Special tools: 9996065, 9996066

1

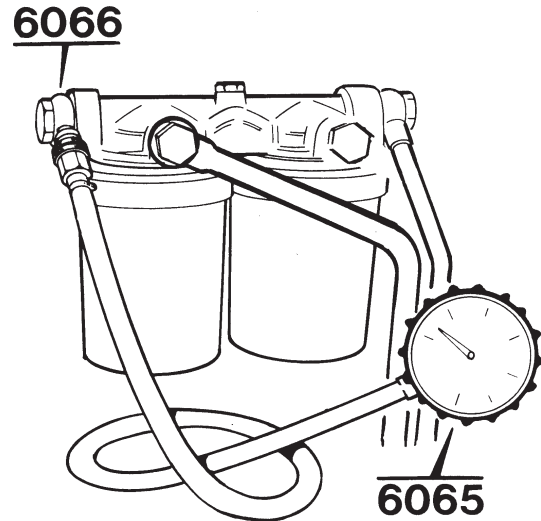

Connect the Banjo nipple 9996066 to the existing outlet on the fuel filter's outlet side; see arrow on the filter adapter (measure the pressure after the fuel has passed through the fuel filter).

NOTE! Watch out for fuel spill.
Connect to manometer 9996065.

2

Run the engine at high speed and then reduce the speed to low idle and read the pressure within one minute. The delivery pressure must not be less than **15.5 psi**. Low delivery pressure can be a result of blocked filter, defective overflow valve or defective feed pump. Check that there is no restriction, e.g. clenched pipe.

Fuel shut-off valve, trouble shooting

TAMD63, TAMD71B*, TAMD72WJ-A*

If the engine does not stop when the key switch is moved to stop position the following items should be checked:

- Check that there is voltage to the solenoid valve's connector when the key switch is in stop position. Violet cable should have voltage on stop.
- Connect to the connector and listen for function noise. Does the valve click when stop is connected? Check the plunge function if necessary.
- Check that the injection pump's overflow valve is tight in the return direction so that fuel cannot reach the injection pump via the return pipe.

* As from engine no. 207181084/xxxx

Fuel shut-off valve, renovation

TAMD63, TAMD71B*, TAMD72WJ-A*

* As from engine no. 207181084/xxxx

1

Clean the fuel shut-off valve carefully.

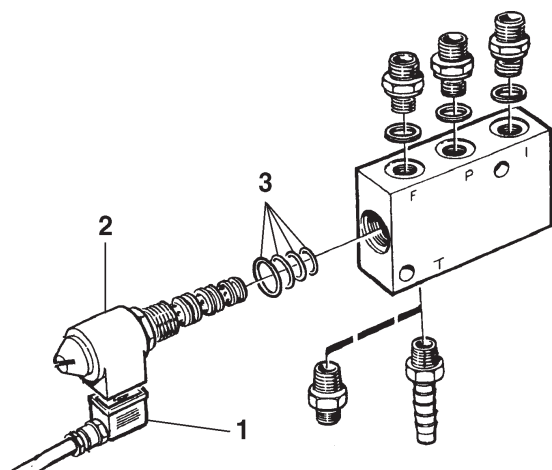

2

Close the fuel cocks and release the fuel hoses from the nipples. Make sure that dirt cannot get into the fuel hoses; fit protective plugs if necessary.

3

Release the terminal (1).

4

Dismantle the valve from the bracket.

5

Brace the valve in a vice with protected jaws.

6

Dismantle the solenoid (2).

7

Blow clean the valve's fuel channels with compressed air.

8

Replace the solenoid's sealing rings (3). Fit the solenoid. Tightening torque 20 ft. lb.

9

Fit the fuel shut-off valve to the bracket.

10

Fit the fuel hoses.

Seal in pump drive, replacement

TAMD61, -62, -71

Special tools: 9996778, 9996779

1

Remove the front valve cover. Remove the rubber plug to the flywheel cover's inspection hole.

2

Turn round the engine in its normal direction of rotations until the valves on the 1st cylinder are closed (compression stroke).

3

Remove the protective plate over the pump coupling.

4

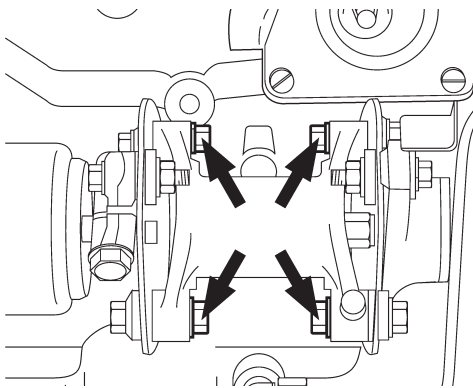

Remove the four screws for the pump coupling.

Note: Do not remove the screws which hold the carrier discs on the carrier.

5

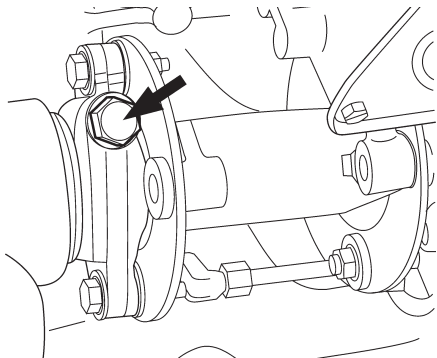

Release the clamping screw which hold the carrier on the drive shaft.

6

Remove the guide sleeves and lift off the pump coupling. Look after the washers between the steel ribs and pump coupling.

5

Remove the front carrier from the drive outlet's shaft journal.

6

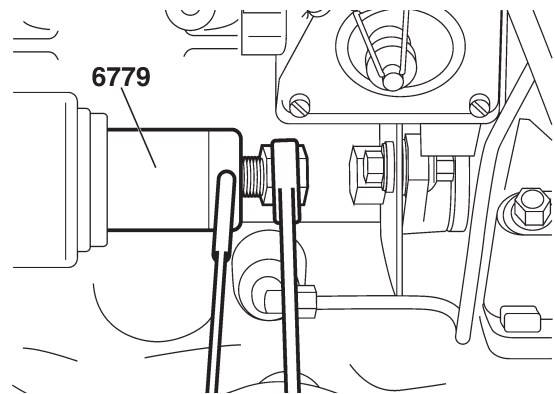

Screw the extractor 9996779 in the seal. Press on the extractor so that its thread cut into the seal's steel ring. Remove the seal.

7

Oil in the new seal and shaft journal. Place the seal on the shaft.

8

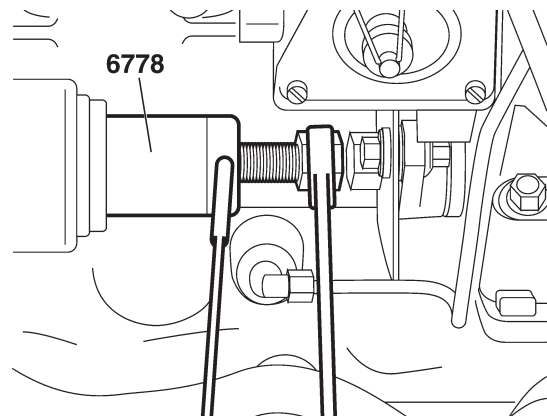

Press in the seal with tool 9996778 until the seal is flush with the housing.

9

Put the front carrier on the drive shaft. Put on the pump coupling together with washers, guide sleeves and screws.

Tighten the screws with a torque of **22 ft. lb.**

10

Adjust the injection pump.

See repair instructions on pages 20–23.

Seal in pump drive, replacement

TAMD63, -72

Injection pump removed

Special tools: 9996640, 9998011, 9998012

Note: The distance between the timing gears bearing housing and the injection pump does not permit space for the tools needed to replace the seal. The injection pump must therefore be dismantled before the seal is replaced.

For dismantling and fitting of the injection pump see the repair instructions on pages 18 and 19, and 24–26.

1

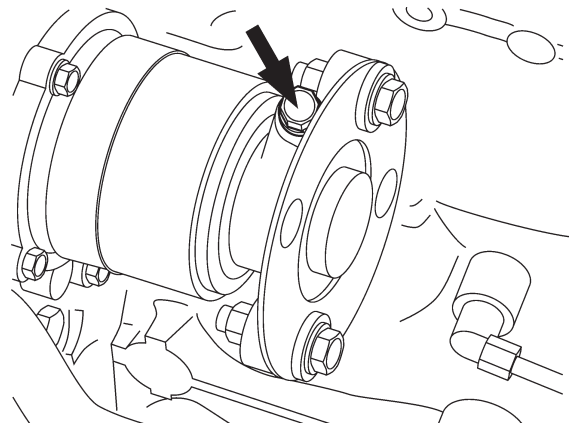

Release the clamping screw and remove the carrier from the shaft.

2

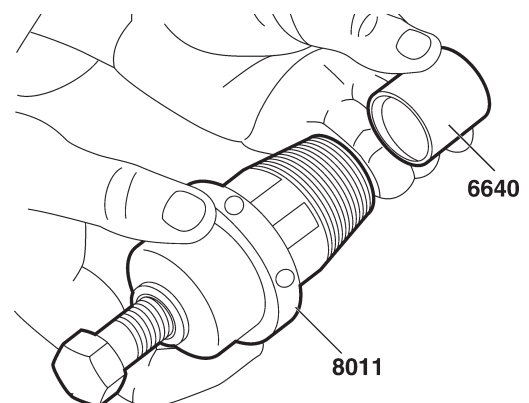

Insert mandrel 9996640 in extractor 9998011. Turn the mandrel with the shallow hole towards the extractor screw.

3

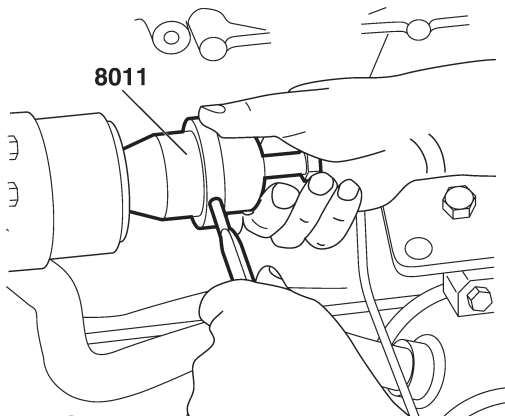

Screw the extractor in the old seal by means of a mandrel.

4

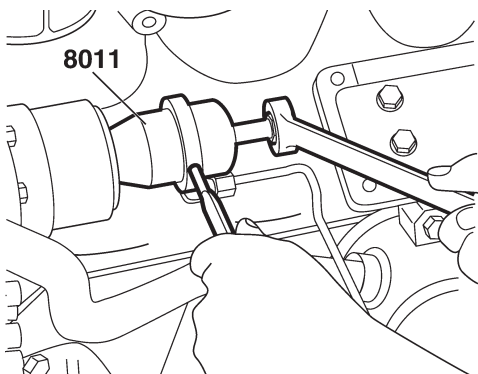

Pull out the old seal by means of screwing in the screw on the extractor, while holding the extractor with the mandrel.

5

Oil in the new seal and shaft.

6

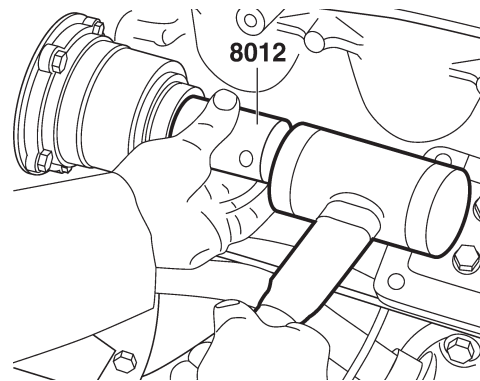

Place the seal on the shaft and tap it in flush with the housing with mandrel 9998012.

7

Put the carrier on the shaft but do **not** tighten the clamping screw.

Fuel injector, replacement

Special tool: 9996643

1

Clean round the fuel injectors and pipe connections.

2

Only applicable for 7(x) series.

Remove the exhaust temperature sensor from the exhaust collector pipe.

3

Remove the leak-off pipe between the fuel injectors and plug the connections.

4

Remove the fuel delivery pipe and plug the connections.

NOTE! The fuel delivery pipes must under no circumstance be bent or re-bent. A damaged fuel delivery pipe must be replaced.

Fuel delivery pipes from TAMD61/62/71 must not be used on TAMD63/72.

5

Remove the nuts for the fuel injectors' anchorage yoke and remove the yoke.

6

Remove the rubber seals round the fuel injectors.

7

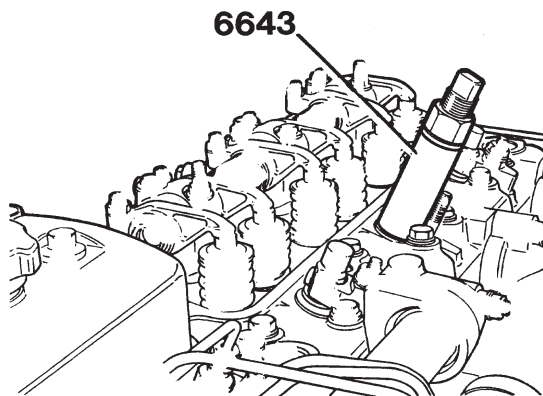

Turn the injectors with a PU-15 wrench and pull them upwards at the same time. If the injector has stuck and can not be pulled up by hand, use extractor 9996643. There is otherwise a risk of water entry.

8

Clean the surface of the copper sleeves to the fuel injectors.

9

Insert the new fuel injectors.

10

Insert new rubber seals round the fuel injectors.

11

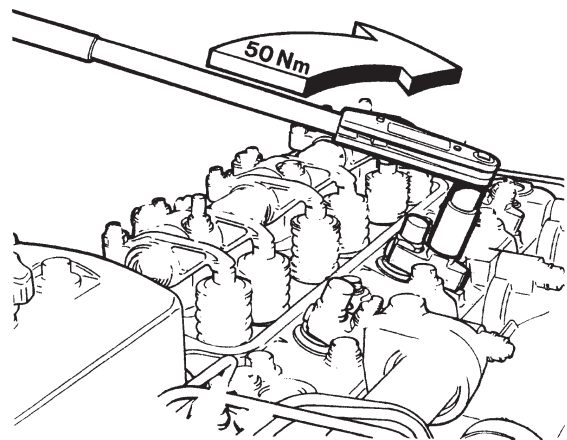

Fit the anchorage yoke and tighten the nuts with a torque of 37 ± 3.7 ft. lb.

12

Fit the leak-off pipe with new copper washers.

13

Fit the fuel delivery pipes.

14

7(x) series only.

Fit the exhaust temperature sensor.

15

Start the engine and check for leakage.

Fuel injector, renovation

1

Clean the exterior of the fuel injector.

2

Take the injector to pieces. If several injectors are cleaned at the same time, make sure that the injector needles and injector nozzles which belong together and have been selectively assembled are not mixed up. To avoid mixing, the nozzles should be put in an injector rack or in different boxes.

3

Clean the injector.

To get an acceptable result when cleaning injectors, it is important that they are cleaned with an ultrasound cleaner. If the workshop does not have access to its own ultrasound cleaner, this can be done at the nearest Bosch workshop.

4

Check the nozzle carefully. Inspection is made with lamp magnifier or microscope. The nozzle sleeve can also be checked in the microscope. If the seat is worn the nozzle needle must be replaced together with the nozzle sleeve or, if only slightly damaged, ground in a nozzle grinding machine.

5

Check the other parts.

6

Dip the nozzle parts in pure diesel or testing oil.

7

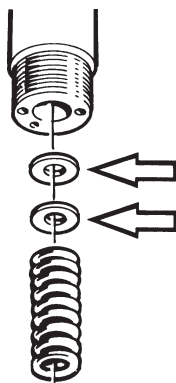

Assemble the nozzle with the same thickness of adjusting washers for the opening pressure as the original ones.

Copper sleeve, cleaning

Special tool: 9812546

1

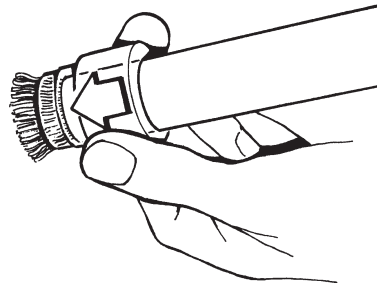

Before the brush is fitted in a drill, press down the mounting sleeve over the brush so that it is held together.

2

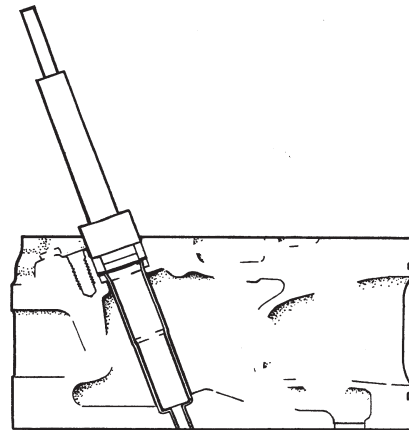

Place the mounting sleeve over the copper sleeve.

3

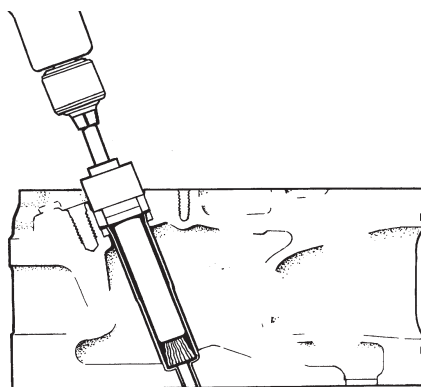

Press down the brush in the copper sleeve. Connect a drill and clean the copper sleeve.

4

After cleaning, blow off any impurities with compressed air.

Recommendation for adjustment of opening pressure, adjustment pressure and replacement of fuel injectors

Fuel injection takes place at very high pressure so that the atomisation of the fuel will be as efficient as possible. The opening pressure of the fuel injectors drops in time below the pressure indicated for new injectors.

This drop in pressure is quite normal and does not affect the function of the fuel injectors and the engine performance to any considerable extent.

Adjustment of the fuel injectors can reduce the service-life of the nozzles.

To avoid unnecessary replacement and adjustment of fuel injectors we provide the following general instructions as to how the fuel injectors should be inspected.

The fuel injectors should not be checked unless there is a clear indication that they are functioning irregularly, e.g. a strong increase in exhaust fumes.

Testing of the opening pressure, adjustment pressure, and tightness, are the most important.

Spray pattern and chatter are more difficult to evaluate and do not give a reliable indication of the condition of the nozzle.

In our service literature we indicate in addition to the opening pressure also the adjustment pressure. These values refer to new fuel injectors, or injectors with new compression springs.

In that the adjustment pressure for a new spring is somewhat higher than the opening pressure there is a certain margin for the compression spring to settle. When a new compression spring has settled, the opening pressure falls by about **8-10 bar**.

The opening pressure will also drop in time, but the fuel injector will continue to function satisfactorily.

Surveys have shown that the pressure drop evens out at approx. **15 %** below the opening pressure, for a used spring. This pressure drop lies within the specified working range.

Tightness testing

During tightness testing a check is made to see if any leakage occurs from the nozzle. If there is leakage it will be between the tip of the nozzle needle and the conical sealing surface of the nozzle sleeve.

Wipe the nozzle tip dry. Pump the pressure up with the pressure gauge connected, to **2 MPa (20 kp/cm²)** beneath the opening pressure of the injector. Hold the pressure constant for **10 seconds**. No fuel should drip from the nozzle tip, but it is permissible if it becomes wet.

Injection pressure and rattle

The condition of the injector is difficult to determine as regards injection pattern and rattle. The performance of an injector in the engine can frequently be acceptable, although both injection pressure and rattle are open to question.

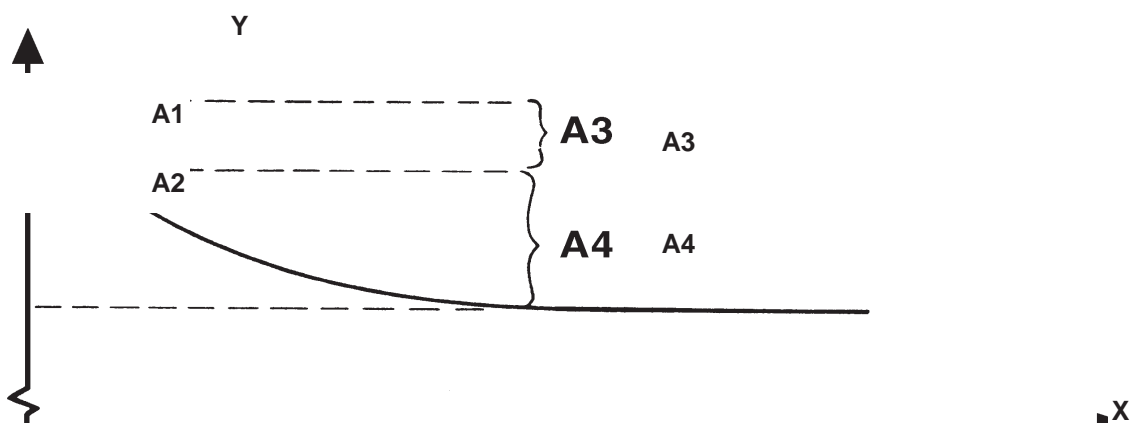

- Y Opening pressure
- X Operation time
- A1 New spring
- A2 Old spring
- A3 8–10 bar difference
- A4 The injector still works well despite a 10% fall in opening pressure.

Opening pressure, adjustment

4

1

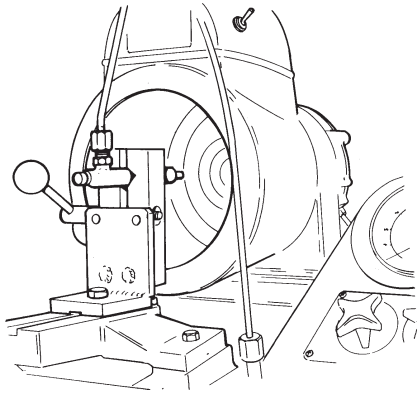

Connect the fuel injector to a nozzle tester.

2

Press the tester lever slowly down until the nozzle releases fuel.

3

Read off the opening pressure on the manometer.

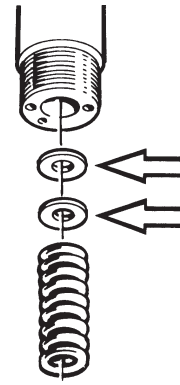

If the opening pressure reading does not correspond with the prescribed value the setting can be changed by replacing the adjusting washers in the fuel injector.

Note: Max. two washers must be used. If the thickest washers are not sufficient to obtain sufficient pressure the spring should be replaced.

Opening pressure/adjustment pressure

Refer to the Workshop Manual "Technical Data" on page 17 for opening pressure and adjustment pressure (new spring).

Spray pattern

At a pump speed of 4–6 strokes/second the spray pattern should be uniform and the fuel atomised. Seal the pipe connections and nozzle tip with protective caps on completion of the test.

Fuel filter, replacement

Special tool: 9996670

1

Clean the filter bracket well.

2

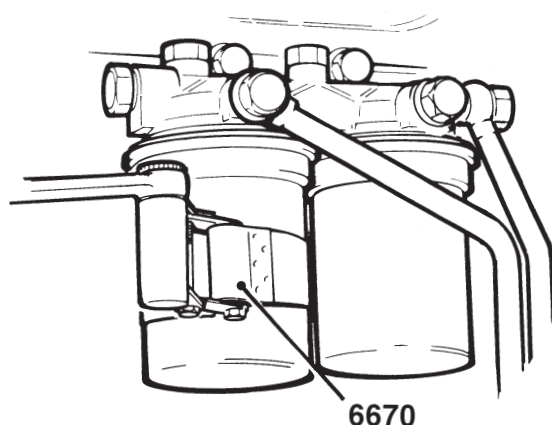

Remove the filter with tool 9996670.

3

Moisten the new filter gaskets with oil and screw them on by hand until the gaskets come in contact with the bracket. Thereafter turn the filter an additional **half turn**.

4

Vent the fuel system. Start the engine and check the tightness round the filter.

Fuel system, venting

1

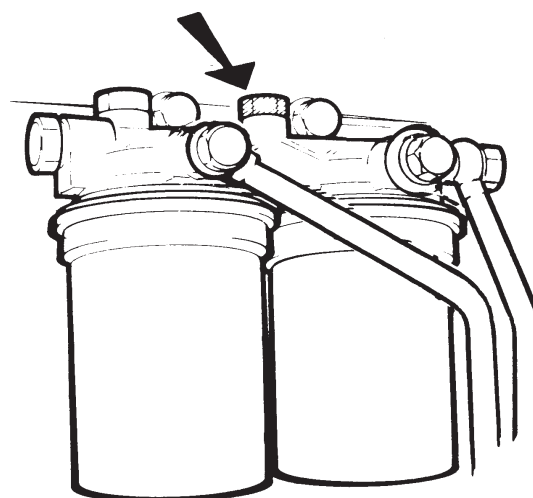

Put a collection vessel beneath the fuel filter. Open the vent nipple on the fuel filter retainer.

2

Fill the fuel system by pumping the feed pump's hand pump. When the fuel which flows out through the vent nipple is free from air bubbles close the vent nipple while the fuel is flowing out. Additional venting is not normally required.

3

If the injection pump requires venting release the connection for the overflow valve. Continue pumping with the hand pump until there are no air bubbles in the fuel.

Thereafter tighten the connection while the fuel is flowing out.

Report form

Do you have any complaints or other comments about this manual? Please make a copy of this page, write your comments down and post it to us. The address is at the bottom of the page. We would prefer you to write in English or Swedish.

From:

.....
.....
.....

Refers to publication:

Publication no.: Issued:

Suggestion/reasons:

.....
.....
.....
.....
.....
.....
.....
.....
.....

Date:

Name:

AB Volvo Penta
Customer Support
Dept. 42200
SE-405 08 Gothenburg
Sweden

