

manual for:

PRM302

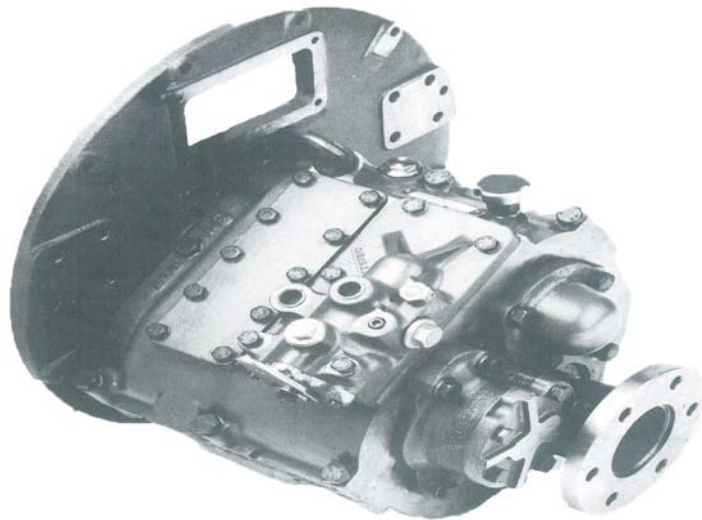

this manual is offered to you by:



DINTRA TRANSMISSIES V.O.F.

Keizerswoert 30 - 3881 LE - Putten - NL

Tel.: +31(0)341-353712 - Fax +31(0)341-360046

www.dintra.com

info@dintra.nl

DINTRA

PRM 302D-Offset
PRM 302A-Angle Drive
PRM 302C-In-Line
BY NEWAGE

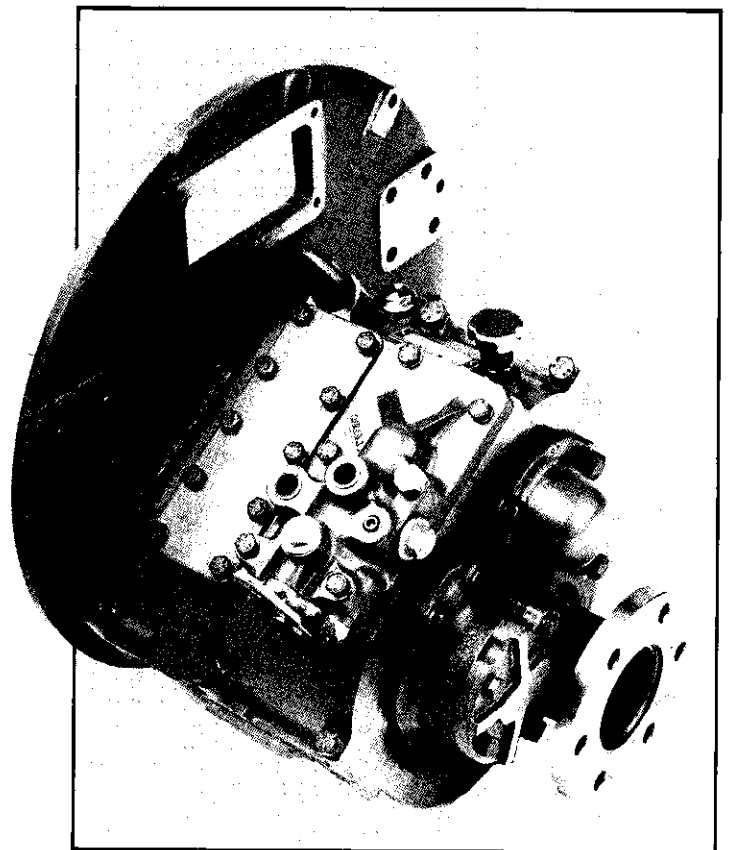

**WORKSHOP
MANUAL**

NEWAGE

NEWAGE TRANSMISSIONS plc
Barlow Road Coventry CV2 2LD England
Telephone 0203-617141 Telex 31333
Cables 'Supagears' Coventry Fax 0203-611845



FORWARD

This workshop manual has been prepared to assist the operator or user of Newage PRM marine gearboxes and also to enable the skilled service engineer to undertake more detailed maintenance and overhaul.

GENERAL INFORMATION

PRM hydraulic marine gearboxes will give trouble-free service provided they are correctly installed, aligned and maintained. In the event of failure, the engine distributor who supplied the gearbox, or the local dealer, should be informed; where this is not possible, Newage Transmissions plc, or the distributor for the area, should be notified. In all communications, verbal or otherwise, the model and serial number of the gearbox must be quoted in order to ensure correct identification and supply of parts.

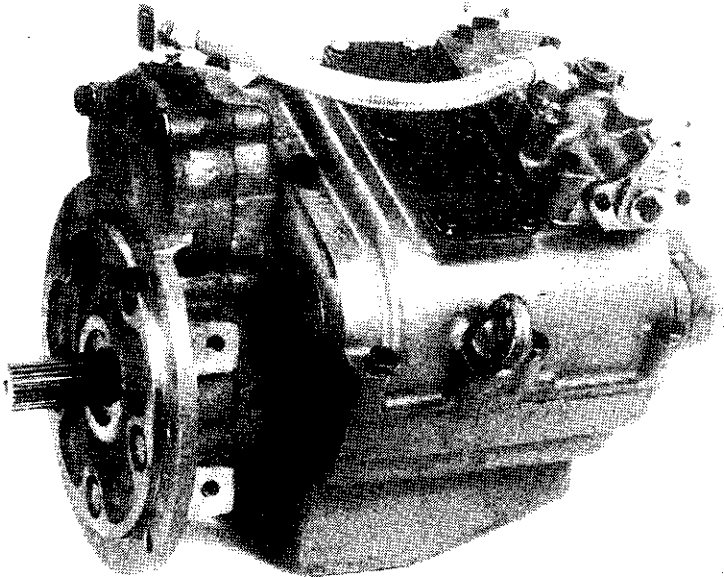

PRM302C

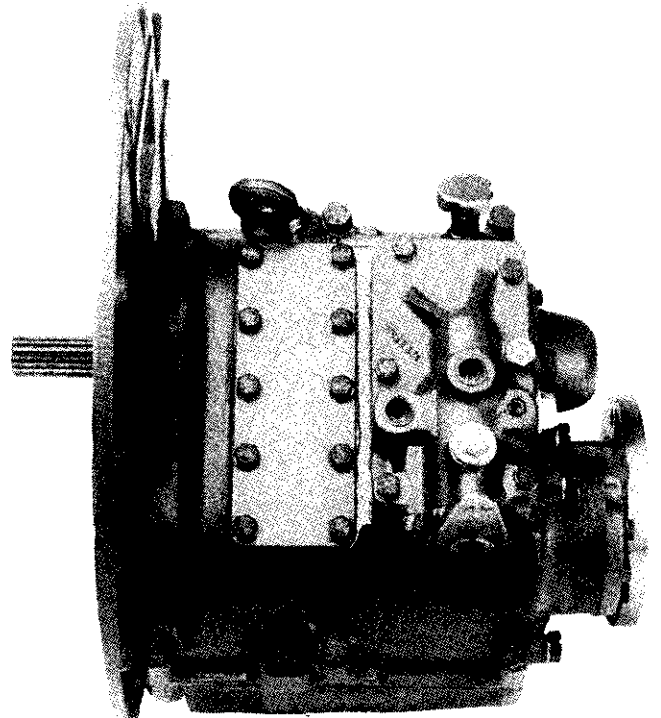

PRM302D

CLAIMS UNDER WARRANTY

Claims for replacement of parts under warranty must always be submitted to the distributor who supplied the gearbox; if this is not possible, application may be made to the nearest distributor or dealer, who must, however, be advised of the supplier's name and address.

SERVICE PARTS

The comprehensive illustrated parts list gives full information and ordering procedure.

IDENTIFICATION PLATE

Every PRM gearbox is fitted with an identification plate on the top half of the gearcase before it leaves the factory; an example of such a plate is shown below.

NEWAGE PRM 123456 302D3 MADE IN ENGLAND	COVENTRY A1234	NEWAGE PRM MADE IN ENGLAND	COVENTRY
--	-------------------	-----------------------------------	----------

Please complete the above box with serial number and specification of your own gearbox.

It will be noted that there are two lines of numbers.

The top line is the gearbox serial number, and should always be quoted when ordering spare parts; this enables the factory to trace the history of the gearbox right back to its date of manufacture and the components and materials used in its production, thus ensuring that the correct components can be supplied as spare parts.

The lower line is the gearbox specification; in the example given this translates as follows:-

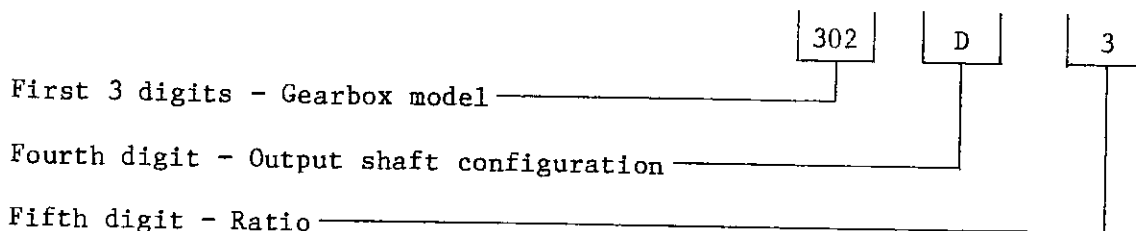

PRM302 SERVICE MANUAL

CONTENTS

	Page
1. GENERAL DATA	6
1.1 Specifications	
1.2 Installation details	
2. INTRODUCTION	9
3. CONSTRUCTION	9
3.1 Gearcase	
3.2 Gear train	
3.3 Gear train - Angle drive	
3.4 Gear Train - In line	
3.5 Valve block	
3.6 Neutral safety start switch	
3.7 Oil pump	
4. OPERATING SYSTEM	12
4.1 Output rotations	
4.2 Hydraulic system	
4.3 Lubrication	
4.4 Approved oils	
5. INSTALLATION	15
5.1 General	
5.2 Checking the engine flywheel housing	
5.3 Checking the engine flywheel	
5.4 Mounting the gearbox to the engine	
5.5 Oil cooler	
5.5.1 PRM302 standard gearbox	
5.5.2 PRM302 with power take off	
5.5.3 PRM302A angle drive	
5.5.4 PRM302C in-line	
5.6 Alignment to propeller shaft	
5.7 Installation angle	
5.8 Twin installations	
5.9 Remote control operating unit	
6. OPERATION	21
6.1 First-time usage	
6.2 Drive selection	
6.3 Trailing (free-wheeling) the propeller	
6.4 Emergency operation	
7. ROUTINE MAINTENANCE	23
7.1 Initial maintenance (25 hours running)	
7.2 Daily checks	
7.3 Annual checks	
7.4 Winter storage	
7.5 Other maintenance operations	

8.	FAULT FINDING	24
9.	SERVICING AND REPAIRS	26
	9.1 Valve block	
	9.2 Oil pump	
	9.3 Removing transmission from boat	
	9.4 Removing input and layshaft assemblies	
	9.5 Servicing input and layshaft assembly components	
	9.5.1 Input shaft oil seal	
	9.5.2 Drive end bearing	
	9.5.3 Clutch assembly	
	9.5.4 Drive pinion	
	9.5.5 Rear end bearing, piston rings and feeder	
	9.5.6 Clutch gear	
	9.6 Replacing the input and layshaft assemblies	
	9.7 Servicing output shaft assembly	
	9.8 Shimming procedures	
10.	POWER TAKE-OFF UNIT	34
	10.1 To fit a PTO unit to an existing gearbox	
	10.2 To repair an existing PTO unit	
11.	8° DOWN ANGLE DRIVE UNIT	35
	11.1 Retrofitting unit to an existing gearbox	
	11.2 Replacement of angle drive gears and bearings	
12.	IN-LINE GEARBOX	37
	12.1 In-line unit removal	
	12.2 Inspection, renewal and shimming	
	12.3 In-line unit rebuild	
13.	TIGHTENING TORQUES	38
14.	SPARES PARTS LIST	39

LIST OF ILLUSTRATIONS

	Page	
Fig. 1	Internal layout diagram	10
Fig. 2	Wiring diagram for neutral safety start device	11
Fig. 3	Oil pump mounting - anti-clockwise engines	11
Fig. 4	Oil pump mounting - clockwise engines	11
Fig. 5	Hydraulic and lubricating oil circuits	13
Fig. 6	Checking engine flywheel and flywheel housing	16
Fig. 7	Engine and gearbox cooling circuit	17
Fig. 8	Oil cooler connections PRM302	17
Fig. 9	Oil cooler connections PRM302 with power take-off	17
Fig. 10	Oil cooler connections PRM302A with angle drive	18
Fig. 11	Oil cooler connections PRM302C - in-line	19
Fig. 12	Propeller rotation, twin installations	20
Fig. 13	Operating cable entry, twin installations	21
Fig. 14	Piston ring fitting procedure	30
Fig. 15	Shimming procedure	33

1. GENERAL DATA

1.1 Specifications

Gear ratios

1.459:1, 1.935:1, 2.565:1, or 2.904 :1

Power rating:

RATIO	PLEASURE		LIGHT COMMERCIAL		HEAVY COMMERCIAL	
	BHP	kW	BHP	kW	BHP	kW
1.459:1, 1.935:1	6.38	4.76	6.19	4.62	5.90	4.40
2.565:1, 2.904:1	6.19	4.62	5.90	4.40	5.90	4.40

MAXIMUM OPERATING SPEEDS: 4000 REV/MIN INTERMITTENT, 3,600 REV/MIN CONTINUOUS

Note: these ratings refer to diesel engines, powers are expressed in BHP and kW per 100 rev/min engine operating speed, and are measured at the engine flywheel. Ratings have been established to ensure the long and trouble-free life of the gearbox which should not, therefore, be used at powers in excess of those shown.

SERVICE CLASSIFICATION DEFINITIONS

PLEASURE: limited to planing hull pleasure craft; operation at full engine throttle not to exceed 5% of total time, with balance of usage at 90% or less of full throttle engine speed, and maximum operating time 500 hours per year. The selection of PRM marine transmissions according to this classification for any commercial boat, or in sport-fishing charter boats or long-range pleasure cruisers, is not approved.

LIGHT COMMERCIAL: planing or semi-displacement craft used in pleasure or commercial applications may qualify for light commercial rating if annual usage is less than 1500 hours and full throttle operation is limited, with most operating time at partial throttle.

HEAVY COMMERCIAL: Newage Transmissions plc recommenda that all displacement and semi-displacement craft used for commercial applications should be classed as Heavy Commercial Duty. In vessels of this type (including trawlers, purse seiners, lobster and crab boats, tugs, ferries, offshore supply boats etc) the marine gearbox is expected to work at full governed engine speed. The power setting of the engine must be known, and must be within the gearbox's permissible heavy commercial rating.

IMPORTANT NOTE:

(1) It is important that the engine, transmission model, reduction ratio and propeller size should be correctly matched so that the engine can attain its rated speed appropriate to the relevant service classification without labouring.

(2) It is also very important to ensure the torsional compatibility of the complete propulsion system from engine through to propeller, since disregarding this may result in gear noise, particularly at low speed operation, and may even result in damage to engine as well as transmission components.

Newage Transmissions plc will provide all possible information and assistance to help find solutions to potential torsional problems, but it is the ultimate responsibility of the person assembling the drive and driven equipment to ensure that they are torsionally compatible.

APPROXIMATE WEIGHTS AND OIL CAPACITIES

	DRY WEIGHT	OIL CAPACITY
PRM302D	68kg (150lb))excluding drive	2.5 litres (4.40 pints)
PRM302A	86kg (190lb))coupling, adaptor	3.0 litres (5.28 pints)
PRM302C	89kg (196kg))and cooler. Additional weight - Power take off: 12 Kg (26.4lb)	3.0 litres (5.28 pints) plus amount reqd to fill cooling circuit.

Input rotation:

Clockwise or anti-clockwise (see section 2).

Output rotation:

Clockwise or anti-clockwise as required (see section 4.1).

Working oil pressure:

1790 kPa (18.3 Kg/cm² - 260 lbf/in²)

Working oil temperature

50°C - 70°C

Maximum permissible temperature 80°C

Transmission cooling:

Transmission cooler must be fitted; provision made for connecting unit to operating valve block.

Capacity of cooler required will vary according to ambient temperature, engine horsepower and other factors, but as a general guide, a cooler of 6.3 kW (8.5 hp) capacity and a flow rate of 27 litres per hour per 1000 rev/min input should be adequate. Suitable coolers are available from Newage Transmissions plc

Input drive couplings:

Flexible drive coupling for flywheels of 10 in, 11.5 in nominal diameter to SAE J620C.

Gearcase:

Heavy duty cast iron for use in marine environment, constructed in two halves for ease of servicing; ribbed internally for rigidity and strength.

Input shaft:

302D, 302A: 29mm (1.14 in) diameter with 16/32 DP involute spline.
302C : 33mm (1.30 in) diameter with 16/32 DP involute spline.

Propeller thrust:

Ahead and astern thrust carried by output shaft bearings of adequate capacity for all Newage approved ratings.

Output flange:

152.4mm (6 in) diameter, with 6 holes, 13mm (0.512 in) diameter on 121mm (4.5 in) PCD.

Installation angle:

The maximum fore and aft installation angle permissible at rest is 17°.

1.3 Installation details

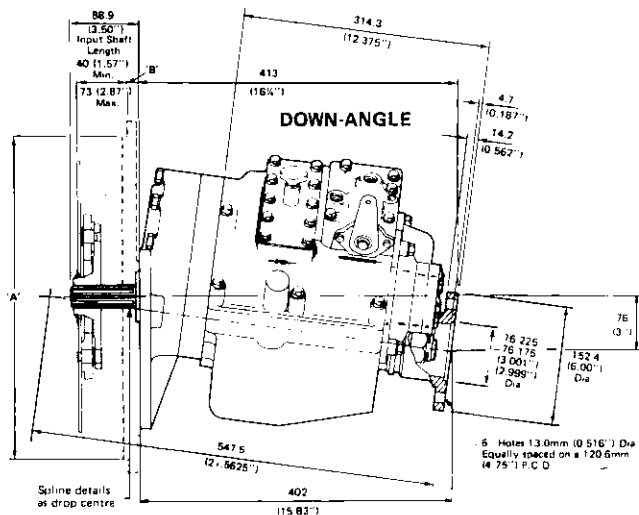

Adaptors	'A'		'B' (Nominal)	
	mm	inches	mm	inches
SAE2	447.68	17.625	15.90	0.625
SAE3	409.58	16.125	15.90	0.625
SAE4	361.95	14.250	19.00	0.750
B/W	209.50	8.2500	28.57	1.125

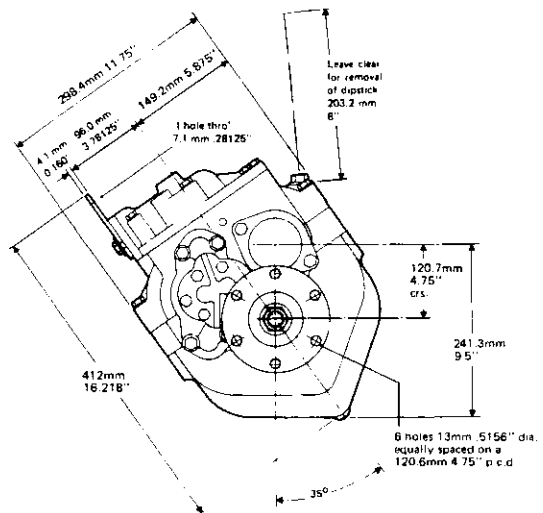
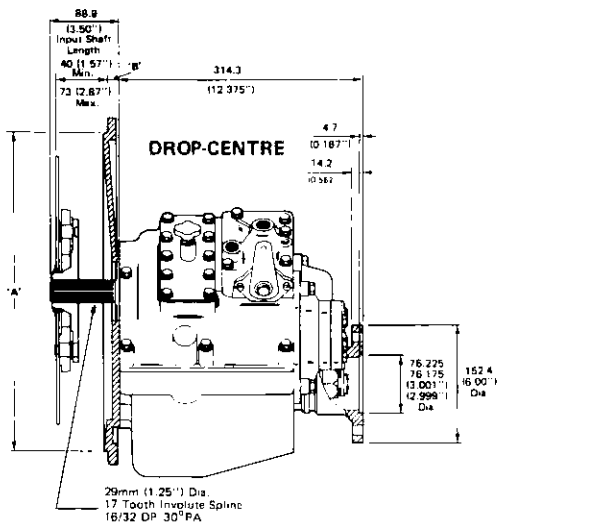

Installation angle

The maximum fore and aft installation angle permissible at rest is 17°

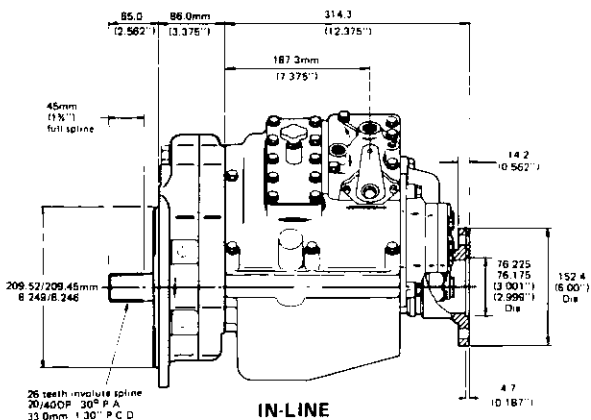

2. INTRODUCTION

Newage PRM marine transmissions are oil-operated gearboxes of the counter-shaft type with separate oil-operated multi-disc clutches (which need no adjustment) for both ahead and astern drive. This design permits full power to be transmitted in astern as well as ahead, and also allows right-hand or left-hand propeller rotation in ahead drive, with identical ratios in ahead and astern.

Both left-hand (anti-clockwise) and right-hand (clockwise) rotating engines can be accommodated.

Note: when describing engine rotations, face the engine on which the transmission is to be mounted and describe the rotation accordingly. Similarly, describe the transmission output rotation as clockwise or anti-clockwise as seen when standing behind the gearbox output coupling facing towards the input or engine end of the transmission.

3. CONSTRUCTION

3.1 Gearcase

The gearcase has been kept free from hydraulic pipes, cylinders and associated components, and the only items mounted externally are the oil pump, hydraulic control block and operating lever.

A magnetic drain plug is provided at the front of the gearcase; this can be removed if required to allow suitable pipework to be connected to a hand-operated drain pump.

Connections are provided on the valve block for the oil cooler and pressure gauge.

3.2 Gear train

The transmission comprises an input shaft assembly, a layshaft assembly and an output shaft.

The input shaft, which is supported by a taper roller bearing at either end, incorporates a drive pinion of the required ratio (running on needle roller bearings), the forward (when used with a right-hand propeller) drive clutch assembly, the clutch gear and a hydraulic actuated piston to operate the clutch.

The layshaft is similarly supported by taper roller bearings and also incorporates a drive pinion of the same ratio (again running on needle roller bearings), the reverse (when used with a right-hand propeller) drive clutch assembly, a clutch gear of opposite hand rotation to that on the input shaft, and a hydraulically actuated piston to operate the clutch.

The output shaft runs on amply proportioned bearings, arranged in such a way that propeller thrust can be satisfactorily absorbed; it also carries the output gear and the output flange.

Internal Layout (with Angle Drive)

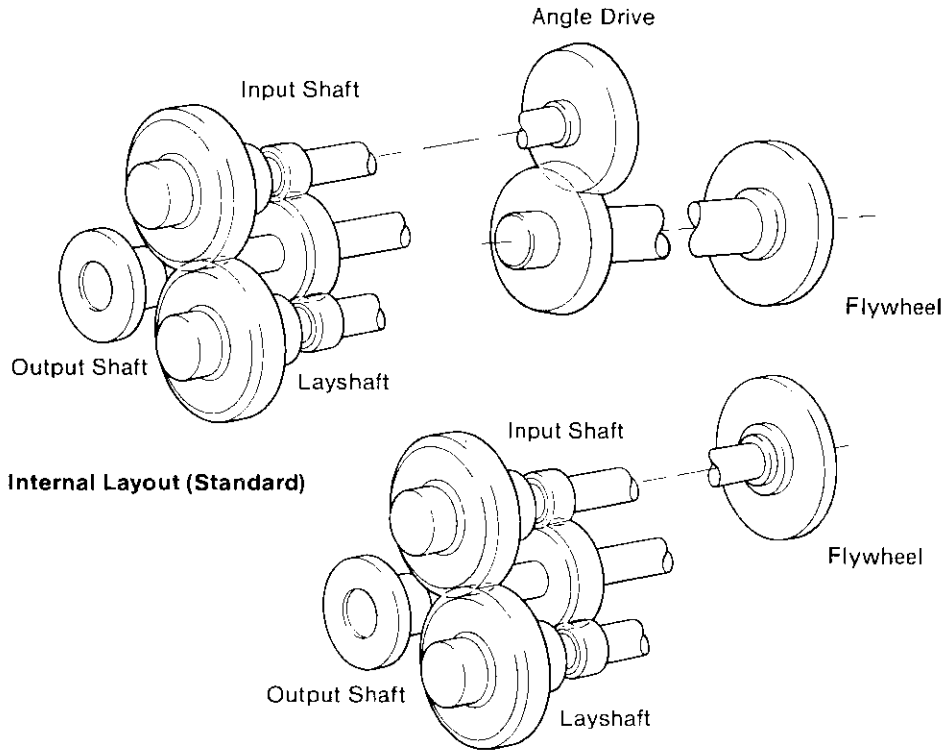

Fig. 1 Internal Layout

3.3 Gear train - Angle drive

The angle drive unit incorporates a pair of conical involute gears so arranged that the output shaft runs at an angle of 8° down relative to the input shaft; it also has the effect of reducing the centre line distance between the engine crankshaft and gearbox output shaft. The purpose of this is to enable the main gearbox to be mounted to the propulsion engine in such a way that the engine can be installed as near as possible to the horizontal whilst maintaining the required propeller shaft line.

Both input and output shafts are supported on bearings of adequate size for all Newage approved ratings.

3.4 Gear train in-line

The in-line gearbox incorporates a matching pair of conical involute arranged that the input shaft of the main gearbox is stepped down to the same centre line as the output shaft, thus allowing the input and output of the gearbox on the same centre line.

Both gears of the in-line unit are supported on bearings of adequate size for all Newage approved ratings.

3.5 Valve Block

The valve block is located on the top of the gearcase and contains the main control valve, integral with which is the high pressure valve which controls the supply to the clutch assemblies. Oil which is surplus to clutch operation requirements is used for lubrication purposes.

The control valve is fitted with a spring-loaded neutral detent; this provides a positive neutral position and ensures positive selection of either ahead or astern drive.

3.6 Neutral safety switch

A neutral safety start switch, which ensures that the engine to which the gearbox is fitted cannot be started unless the gearbox is in neutral, is available as an optional extra.

This device is of obvious benefit, since it will help prevent accident or damage caused by a boat moving ahead or astern on engine start-up in a crowded marina or other area.

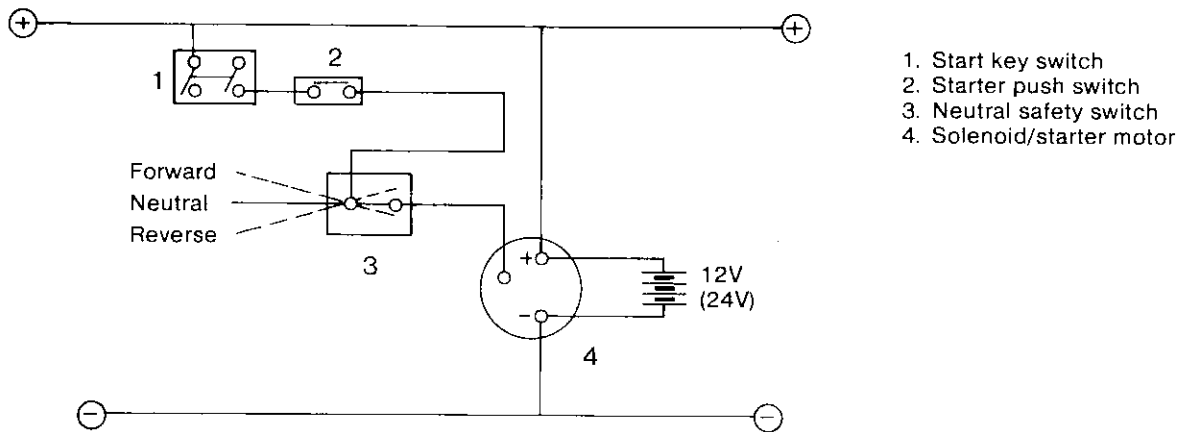

Fig. 2. Wiring Diagram for Neutral Safety Start Device.

When used, the switch is located on the valve block (see item C on the parts list) and should be wired into the starter circuit as shown in Fig. 3.

3.7 Oil pump

A cast iron gear-type pump externally mounted at the rear of the gearcase and normally driven by the layshaft, supplies oil at high pressure for actuation of the clutch assemblies, and at lower pressure for lubrication circuits.

When the transmission is used with anti-clockwise engines (looking at the flywheel) or with clockwise engines if the gearbox is a PRM302A or PRM302C, the oil pump is fitted in its standard position. For clockwise engines, or anti-clockwise for PRM302A and PRM302C the pump is turned through 180° to standard (see diagrams).

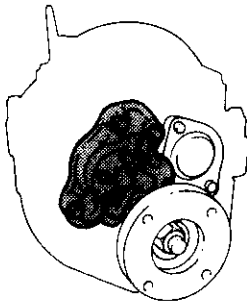

Fig. 3 Oil Pump Mounting – anti-clockwise engines (or clockwise with Angle Drive or In-Line)

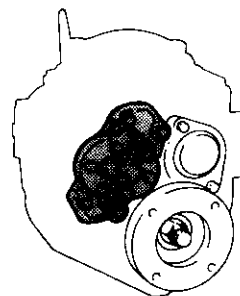

Fig. 4. Oil Pump Mounting – clockwise engines (or anti-clockwise with Angle Drive or In-Line)

Note: Unless otherwise specified at the time of ordering, we will assume anti-clockwise rotating engine and the oil pump will be mounted accordingly.

If a clockwise input rotation is specified when the order is placed, the pump will automatically be mounted in the appropriate position.

4. OPERATING SYSTEM

4.1 Output rotations





With the control lever at the mid-point of travel or neutral position and the engine running, the splined input shaft and the clutch gear rotate at engine speed. The clutch gear is in constant mesh with the clutch gear on the layshaft which is therefore also driven at engine speed, but in the opposite rotation. Since neither clutch is engaged, the drive pinions do not rotate.

When the control lever is moved to the 'ahead' position the hydraulic system is actuated and oil is directed at high pressure to the clutch on the appropriate shaft; the clutch engages and engine drive is directed to the forward drive pinion. The pinion turns the gear on the output shaft and the propeller shaft and propeller are rotated in the direction corresponding to ahead movement of the vessel.





Similarly, when the control lever is moved to the 'astern' position, the clutch on the opposite shaft is engaged and drive applied to the reverse pinion. This turns the output shaft gear in the opposite direction; and the propeller shaft and propeller rotate in the direction corresponding to astern movement of the vessel.

Gearbox output rotation

Engine rotation anti-clockwise

	PRM302A & PRM302C	PRM302D
Lever Backward		
Lever Forward		

Engine rotation clockwise

	PRM302A & PRM302C	PRM302D
Lever Backward		
Lever Forward		

Note: (i) Rotations are as seen looking from the propeller forward to the gearbox.

(ii) Anti-clockwise engines are by far the most common, and the standard gearbox build therefore assumes an anti-clockwise input.

4.2 Hydraulic system

Oil is pumped from the gearbox sump through the internal supply pipe and is delivered to the control block, which incorporates a high pressure valve to ensure that the correct operating pressure is maintained.

When the operating lever is moved, oil is delivered under pressure to a feeder on either the input shaft or layshaft and thence to a piston which actuates the appropriate clutch for either ahead or astern drive.

Oil in excess of that required for hydraulic actuation is used for lubricating the gearbox.

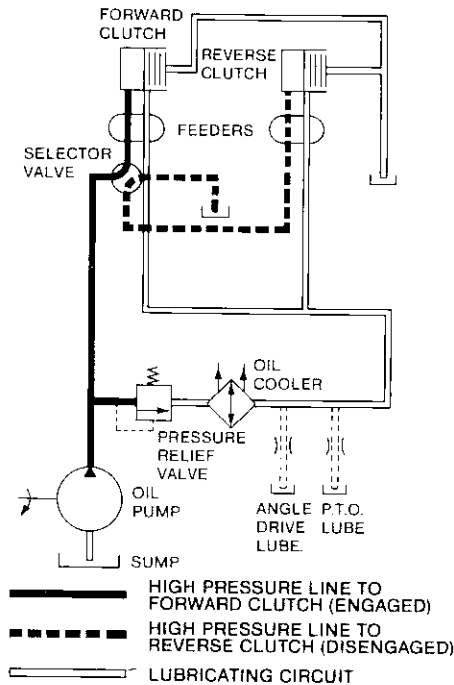

Fig. 5. Hydraulic and Lubricating Oil Circuits.

4.3 Lubrication

Oil for lubrication purposes is also delivered via the internal supply pipe to the control block. Irrespective of whether ahead or astern is engaged oil is diverted from the discharge side of the pressure relief valve to an external oil cooler. After passing through the cooler, the oil is directed through channels on the valve block to the feeders and thence through the layshaft and drive shaft to lubricate the clutch assemblies.

4.4 Approved oils

APPROVED LUBRICANTS – PRM MARINE GEARBOXES

Company	Ambient Temperature Below 0°C	Ambient Temperature 0°C – 30°C	Ambient Temperature Above 30°C
BP	BP Vanellus M20-50	BP Vanellus M20 50	BP Vanellus M20-50
Castrol	Castrol GTX or Deusol CRB 20W/50	Castrol GTX or Deusol CRB 20W/50	Castrol GTX or Deusol CRB 20W/50
Century	Century Supreme 20W/50 or Centlube Supreme 10W/30	Century Supreme 20W/50 or Centlube Supreme 10W/30	Century Supreme 20W/50
Chevron	Chevron Delo 100 10W or Chevron Delo 200 10W	Chevron Delo 100 20W/20 or Chevron Delo 200 20W/20	Chevron Delo 100 30 or Chevron Delo 200 30
Conoco	Conoco 20W/50 or Conoco HD 10W/30	Conoco 20W/50 or Conoco HD 10W/30	Conoco 20W/50
Duckhams	Fleetol Multilite	Q Motor Oil or Fleetol Multi-V	Q Motor Oil or Fleetol Multi-V
Elf	Cougar 15W/30	Cougar 15W/30	Cougar 15W/30
Esso	Esso Superlube or Essolube HDX Plus 10W 30 or Essolube XD 3 10W	Esso Superlube or Essolube HDX Plus 30 or Tromar HD30	Essolube HDX Plus 30 or Tromar HD30 or Essolube XD-3 30
Fina	Fina Dilano 20 or Fina 20W/50	Fina Dilano 30 or Fina 20W/50	Fina Dilano 40 or Fina 20W/50
Gulf	G.M.O. XHD 10W/30 or G.M.O. XHD 10W	G.M.O. XHD 10W/30 or G.M.O. XHD 20W/20	G.M.O. XHD 10W/30 or G.M.O. XHD 30
Mobil	Mobil Super 15W 50 or Delvac Special 10W-30 or Delvac Super 15W-40	Mobil Super 15W-50 or Delvac Special 10W-30 or Delvac Super 15W-40	Mobil Super 15W-50 or Delvac Special 10W-30 or Delvac Super 15W-40
Shell	Shell Super Motor Oil or Rotella TX 20W/40	Shell Super Motor Oil or Rotella TX 20W/40	Shell Super Motor Oil or Rotella TX 20W/40
Silkolene	Chatsworth 10 Engine Oil or Permavisco 20W650 Engine Oil	Chatsworth 20 Engine Oil or Permavisco 20W/50 Engine Oil	Chatsworth 30 Engine Oil or Permavisco 20W/50 Engine Oil
Texaco	Ursatex 20W-50 or Ursa Extra Duty 20W-40	Ursatex 20W-50 or Ursa Extra Duty 20W 40	Ursatex 20W-50 or Ursa Extra Duty 20W-40
Total	GTS or HD2 M 20W/50	GTS or HD2 M 20W/50	GTS or HD2 M 20W/50
Valvoline	Super HPO 10W or HDS HDM 10W Grades	XLD 15W 50	XLD 15W 50 or All Climate 20W-50

Customers wishing to use any oil not listed above should send the relevant details to Newage for prior approval. Failure to do so may result in the forfeiture of warranty cover since no claims under warranty will be entertained if oil of the wrong specification is used.

5. INSTALLATION

5.1 General

The Newage PRM302 marine gearbox is supplied with a choice of adaptor plates to SAE2, SAE3, or SAE4 specifications thus allowing the transmission to be mounted to engine flywheel housings of equivalent specification.

Drive is transmitted from the engine to the gearbox via a flexible input coupling which bolts to the engine flywheel with the gearbox input shaft inserted into its centre.

These components enjoy a degree of torsional flexibility, the purpose of which is to damp down engine torsional or cyclic vibrations and prevent them being passed to the transmission.

The strongest engine vibrations are usually those caused by firing in the cylinders; diesel engines which have high compression ratios, usually generate stronger vibration pulses than petrol (gasolene) engines; and it is often the case that of two engines of roughly equivalent size, the one having the greater number of cylinders will tend to run more smoothly than the one with fewer cylinders, although this is by no means always the case.

In all marine installations, correct alignment is of the utmost importance - misalignment can cause noise, vibration and premature failure - and we strongly recommend that all the procedures detailed in this manual are carefully followed.

5.2 Checking the engine flywheel housing

Attach a dial test indicator, calibrated in units of 0.001 in. (0.025mm) or smaller, to the flywheel so that the measuring stylus of the indicator is perpendicular to the bore of the flywheel housing (bore A on Fig. 6). Rotate the flywheel and check the deviation on the indicator over one complete revolution: this should not exceed 0.006 in. (0.152mm) total indicator reading.

With the dial test indicator still attached to the flywheel, re-position the stylus so that it is perpendicular to the face of the flywheel housing (face B on Fig. 6). Rotate the flywheel and check the deviation over the one complete revolution; again, this should not exceed 0.006 in. (0.152mm) total indicator reading.

5.3 Checking the engine flywheel

Attach a dial test indicator, calibrated to 0.001 in (0.025 mm) or less, to the engine flywheel housing so that the measuring stylus of the indicator is perpendicular to the bore of the register in the flywheel (bore C on Fig 6). Rotate the flywheel through one complete revolution and note the deviation, this should not exceed 0.005 in (0.125mm) total indicator reading.

With the dial test indicator still attached to the flywheel housing, reposition the stylus so that it is perpendicular to the face of the flywheel register (D on Fig 6). Rotate the flywheel through one complete revolution and note the deviation, this should not exceed 0.005 (0.125mm) total indicator reading.

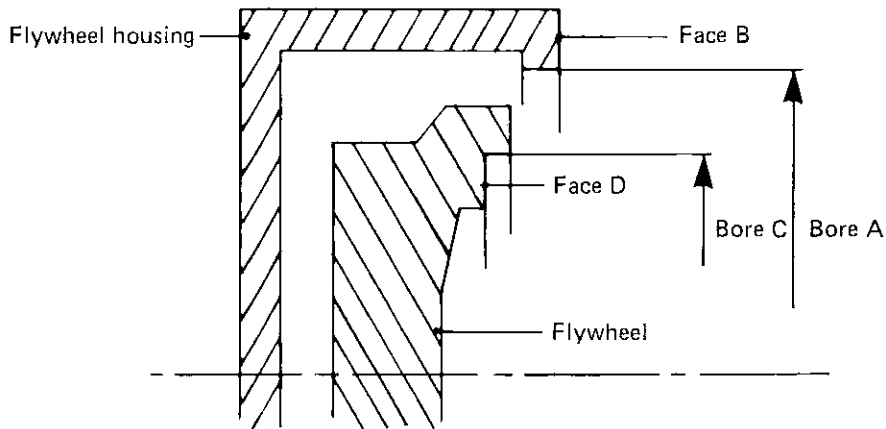

Fig. 6. Checking engine flywheel and flywheel housing.

5.4 Mounting the gearbox to the engine

1. Mount the flexible input coupling to the flywheel, using an alignment mandrel if available, and bolt it to the flywheel using the holes provided. Where components to SAE standard are used, the outside diameter of the drive plate or coupling should be a close fit in the register on the flywheel.

If a mandrel is not available, tighten the mounting bolts, just sufficiently to prevent free movement, assemble the gearbox to the coupling, and rotate the engine two or three revolutions by hand to align the plate. Tighten up two or three opposite bolts, using the inspection window provided on the gearbox adaptor flange.

2. Remove the gearbox and fully tighten the flexible input coupling bolts.
3. Taking care to ensure correct alignment, mount the adaptor flange to the front of the gearbox.
4. Offer up the gearbox and adaptor to the input coupling and engine flywheel housing at the correct angle of inclination to obtain the shaft offset and insert the gearbox input shaft into the centre of the coupling (it may be necessary to rock the shaft slightly to ensure that the shaft enters). Press the assembly fully into position, align the mounting holes in the adaptor flange with those on the flywheel housing and bolt securely.

5.5 Oil cooler

All Newage PRM302 gearboxes must be fitted with an oil cooler to maintain correct working temperatures. To permit a suitable cooler to be fitted, two 3/8 in. BSP connections are provided on the valve block, and these are blanked off with "Redcap" seals on delivery from the factory.

The gearbox oil cooler is normally mounted on the gearbox adaptor flange or the bulkhead of the boat, and then connected into the cooling system on the engine; one method of arranging the engine and gearbox cooling circuit is shown below.

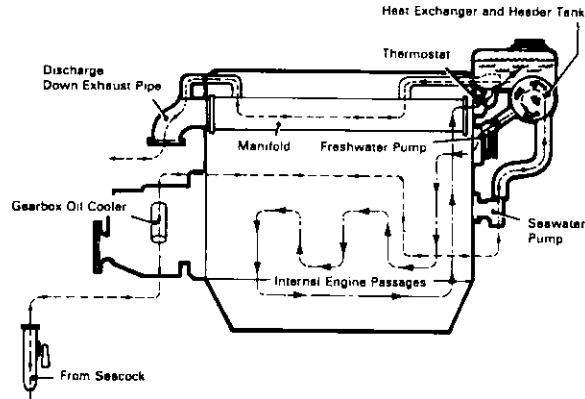

Fig. 7. Gearbox and Engine Cooling Circuit

5.5.1 PRM302 standard gearbox

Remove the "Redcap" seals from the valve block and connect, via suitable hoses, to inlet connections on the oil cooler, which can then be incorporated into the engine cooling system as outlined above.

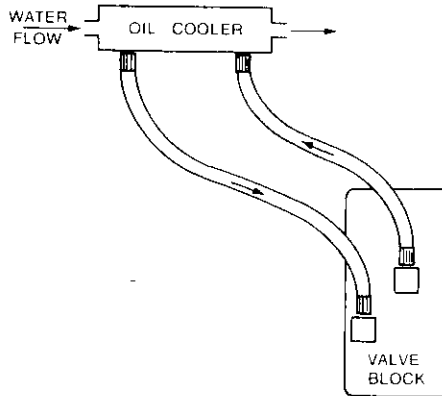

Fig. 8. Oil Cooler Connections PRM302

5.5.2 PRM302 with power take-off

Oil returned from the cooler to the valve block is first passed through the power take-off unit to provide lubrication and the method of connecting the cooling system is as follows:

- a) remove "Redcap" seals from the valve block.
- b) connect the valve block outlet to oil cooler inlet
- c) connect the oil cooler outlet to the PTO inlet.
- d) complete the circuit by connecting the PTO outlet to the valve block inlet.

The oil cooler can now be connected to the engine cooling system as outlined above.

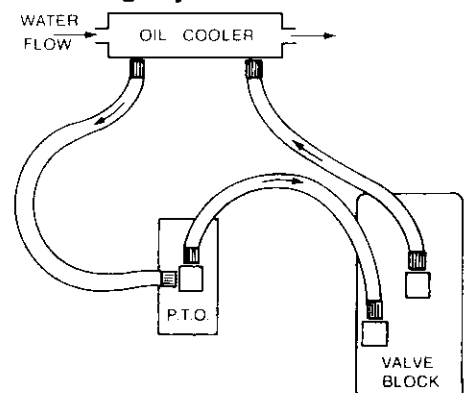

Fig. 9. Oil Cooler Connections — PRM302 with Power Take Off.

5.5.3 PRM302A (with angle drive)

Oil returned from the cooler to the valve block is first passed through the angle drive unit to provide lubrication, and the method of connecting the cooling system is as follows:

- a) remove "Redcap" seals from the valve block.
- b) connect valve block outlet to oil cooler inlet.
- c) connect oil cooler outlet to the angle drive inlet.
- d) complete the circuit by connecting the angle drive outlet to the valve block inlet.

The gearbox oil cooler can now be connected to the engine cooling system as described above.

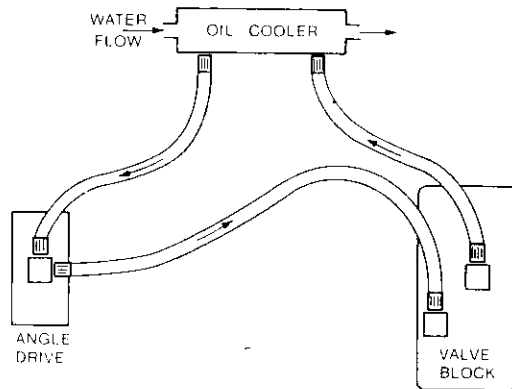

Fig. 10. Oil Cooler Connections – PRM302A with Angle Drive.

Note: Operating oil temperature should not exceed 80°C under any circumstances. If the checks listed in the fault-finding chart have been carried out without any fault being found and the gearbox consistently runs at a temperature higher than 70°C, Newage strongly recommends that a larger capacity oil cooler be fitted.

5.5.4 PRM302C (in-line)

Oil returned from the cooler to the valve block is first passed through the in-line unit to provide lubrication, and the method of connecting the cooling system is as follows:

- a) remove "Redcap" seals from the valve block.
- b) connect valve block outlet to oil cooler inlet.
- c) connect oil cooler outlet to the in-line inlet.
- d) complete the circuit by connecting the in-line outlet to the valve block inlet.

The gearbox oil cooler can now be connected to the engine cooling system as described above.

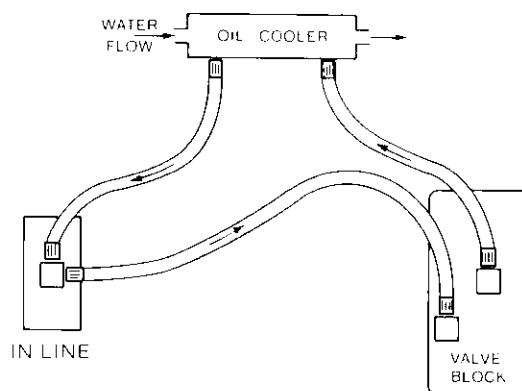

Fig. 11 Oil Cooler Connections PRM302C – In-Line

Note: Operating oil temperature should not exceed 80°C under any circumstances. If the checks listed in the fault-finding chart have been carried out without any fault being found and the gearbox consistently runs at a temperature higher than 70°C, Newage strongly recommends that a larger capacity oil cooler be fitted.

5.6 Alignment to propeller shaft

Alignment between the propeller shaft and the mating flange on the gearbox output shaft is extremely important since excessive vibration and stress leading to damage and perhaps even failure can occur if correct alignment is not achieved.

It is generally considered preferable to couple the propeller shaft direct to the gearbox output flange using a rigid coupling particularly in the majority of boats whose hulls have sufficient rigidity as not to allow flexing in heavy sea conditions, which could cause the engine and transmission to shift in relation to the propeller shaft.

The two main conditions when a flexible coupling should be used are:

- a) in boats whose hulls are insufficiently rigid to prevent the flexing referred to above, and
- b) in cases where the engine is mounted on flexible mounts.

In both instances, the flexible coupling will isolate engine vibration or other movement from the propeller shaft, thereby enabling the correct alignment to the propeller shaft and the stern tube to be maintained.

Whether a solid or flexible coupling is used, it is extremely important that the following points are carefully checked:

- i) the coupling should be a tight press fit on the shaft and the keyway accurately made to the correct size, and
- ii) the two halves of the coupling should be carefully aligned. This should be done by bringing the two flanges close enough together so that a feeler gauge can be used to check the vertical and horizontal alignment.

Since the propeller shaft line is normally fixed in the boat, alignment is usually obtained by adjusting engine mount shims on the mounts themselves.

Note: Whenever possible, the engine and gearbox should be installed whilst the hull is afloat, otherwise there is a danger of the hull distorting because of insufficient support over its surface. If the engine and transmission are fitted before the hull is in water, the installation should be very carefully re-checked for alignment after launching.

5.7 Installation angle

The transmissions should normally be installed so that the maximum fore and aft angle relative to the water line does not exceed 17° with the boat at rest.

In the case of the Newage PRM302A (angle drive) the transmission provides 8° down angle on the output shaft; it also has the effect of reducing the centre distance between the engine crankshaft and the gearbox output shaft, and enables the engine to be mounted nearer to the horizontal than would be the case with conventional in-line or drop centre transmissions. This has the effect of reducing the overall height required for installing the engine and will also help to prolong engine life.

5.8 Twin installation

The rotation of a propeller, even in a single engine installation, tends to have a slight "turning" effect on the handling of the boat, but this can normally be corrected with very slight adjustments on the rudder.

In twin installations, the turning effect on the handling of the boat will be much more pronounced if both propellers rotate in the same direction. It is therefore desirable that "handed" (i.e. counter-rotating) propellers be fitted, and it is for this reason that PRM gearboxes are capable of providing either hand of output rotation at any of the available gear ratios.

It is also preferable for the starboard (right-hand) propeller to rotate clockwise and the port (left-hand) anti-clockwise rather than the other way about since in the latter case, when the propeller blades are at the lowest point of their rotational arc they tend to create a vacuum which affects the other propeller by reducing the flow of water to it; furthermore, when the boat is making a tight turn with one gearbox in "ahead" and the other in "astern", the thrust side of one propeller will be acting diametrically opposite to the other one, causing the boat to be deflected off line and thus delaying completion of the manoeuvre.

When connecting remote control units for twin engine/gearbox installations; it should be remembered that forward operation of the gearbox operating lever will produce output rotation as engine (generally left-hand, or anti-clockwise).

Therefore, in order to provide counter-rotation of the two propeller shafts in the correct direction for "ahead" drive, with both the remote control operating levers in the "ahead" position, the operating controls should be fitted so that the cable to the starboard gearbox moves the operating lever back, to provide right-hand rotation.

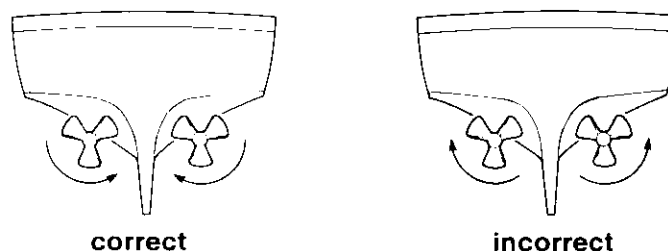
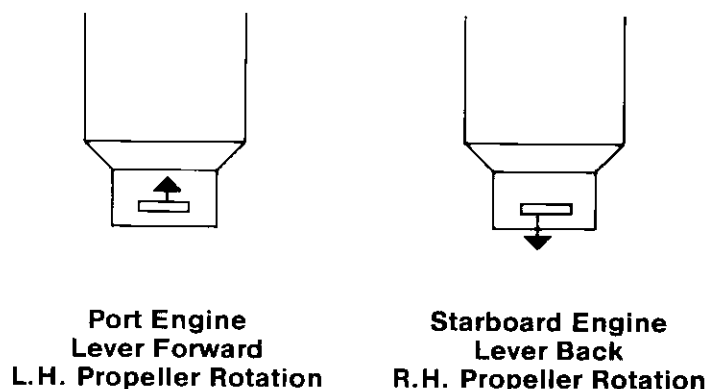

Fig. 12. Propeller Rotation — Twin Installations



Note: When an Angle Drive or In-Line gearbox is fitted, lever movement will be reversed.

Fig. 13. Operating Lever Movement for Ahead Drive, Twin Installations

Note: Lever will be reversed for PRM302A and PRM302C gearboxes.

5.9 Remote control operating systems

All PRM gearboxes can be used with remote control operating systems and indeed the use of the single lever type of remote control, which links the engine throttle to the gearbox operating lever, is highly recommended.

The following points should be noted:

- (i) The gearbox operating lever is provided with a positive neutral position, which greatly assists the setting up of the remote control unit.
- (ii) care should be taken to ensure that the cable moves the gearbox operating lever approximately 1/16" (2mm) short of its maximum forward or backward travel to prevent the lever being brought hard up against the end stop with every gear shift.

The control equipment should in all cases be connected in accordance with the manufacturer's recommendations.

6. OPERATION

6.1 First time usage

Before starting the engine fill the gearbox to the correct level with a suitable oil (refer to recommended list, section 4.4).

Ensure the gearbox is in neutral it is recommended that the optional neutral safety switch (if fitted) be wired into the starter circuit to avoid uncontrolled boat movement on start up.

Start the engine and gearbox, allowing the oil to circulate, then stop the engine and allow to settle. Re-check the gearbox oil and top up if necessary to the maximum mark on the dipstick.

With the more common left-hand (anti-clockwise) rotating engines, moving the gearbox operating lever backwards will provide right-hand propeller rotation, and moving the lever forward will provide left-hand propeller rotation.

If the gearbox is used with the less common right-hand (clockwise) rotating engines, the operation is then reversed:-
Moving the gearbox operating lever backwards provides left-hand propeller rotation and forwards provides right-hand propeller rotation.

Note: If the gearbox is a PRM302A or a PRM302C then the above operating lever movements are reversed.

Note: Engine and propeller rotations are described as seen looking forward from the propeller to the gearbox.

6.2 Drive selection

The Newage PRM302 has been designed and tested to ensure rapid shifts from ahead to astern or vice versa can be operated at full horsepower, ratings and speeds, and the transmission will respond rapidly in these circumstances.

Full power reversals, however, do place abnormal, even if short-lived, loads on the gearbox, and operating life will be prolonged if full power reversals are reserved for emergency use only.

Newage recommend that when changing direction the engine speed be brought down to approximately 1000 rev/min. For this reason we also recommend the fitment of a proprietary single lever remote control operating system which links the engine throttle control to the gearbox operating lever.

6.3 Trailing (free-wheeling) the propeller

The bearings used in the Newage PRM302 gearbox have been carefully selected to ensure that prolonged trailing (free-wheeling) of the propeller will not have any detrimental effect on the transmission. This allows the propeller to turn freely with the engine shut down and makes the Newage PRM302 particularly suited for use in auxiliary sailboats, motor sailers or multi-engine installations where the boat may be operated with one or more engines shut down.

It is not therefore necessary to provide any propeller shaft locking device to protect the transmission, although in the case of sailing yachts and other high performance sailboats fitted with two bladed propellers, it may be desirable to fit a propshaft lock so that the propeller can be locked behind the dead-wood to reduce drag.

Where propellers are allowed to free-wheel they can be a useful source of free auxiliary power; if a flat pulley is fitted to the propeller shaft a small generator can be belt driven for charging batteries (although care must be taken not to apply excessive side-load which would cause vibration and misalignment).

6.4 Emergency operation

Included as standard in every Newage PRM302 gearbox is a "Get You Home" device allowing the gearbox to be mechanically locked in 'ahead' drive in the unlikely event of hydraulic clutch failure.

The method of operation is as follows:

1. Remove top cover (located alongside the valve block).

2. Select the shaft to provide the appropriate propeller rotation (see note (a) below) and rotate until the spring clip holding the two screws in position is accessible.
3. Remove the spring clip and tighten the two clamping screws, thus mechanically locking the clutch pack in drive.
4. Check that the dipstick does not foul the head of the clamping screws. If it does, remove the dipstick and plug the hole with a clean rag.
5. Ensure that there is sufficient oil in the gearbox to avoid further damage and refit the top cover.
6. Select neutral on the operating lever and disconnect the operating cable.

The engine can now be run. Newage recommends a maximum 1/3 full throttle to minimise the possibility of further damage to the transmission.

Note:

- a) Assuming an anti-clockwise rotating engine, the shaft to select is:
 - for left-hand propeller rotation, the left-hand shaft;
(right-hand shaft for PRM302A and PRM302C).
 - for right-hand propeller rotation, the right-hand shaft;
(left-hand shaft for PRM302A and PRM302C).

When looking forward from the propeller to the gearbox.

- b) When emergency drive is in operation, astern or neutral cannot be engaged and there is no means of stopping the boat using the gearbox.
- c) After emergency drive has been used, qualified assistance should be sought to give the transmission a thorough check before the gearbox is used again.
- d) Always disconnect the operating cable and ensure the gearbox operating lever is in neutral before engaging emergency drive.
- e) Never use the top cover for topping up with oil.

7. ROUTINE MAINTENANCE

7.1. Initial maintenance (after 25 hours running)

Drain all oil from the gearbox and refill with one of the recommended lubricants. Operate the engine and gearbox, allowing the oil to circulate, then stop the engine and allow to settle. Re-check the oil level and top up if necessary to the maximum mark on the dipstick.

7.2 Daily check

1. Check the gearbox oil level
2. Make visual inspection of the general condition of the transmission and check for oil leaks, especially at the output shaft seal and at gasket sealing surfaces.

3. Listen for any unusual noises and check their cause.

7.3 Annual checks

1. Check oil cooler connections.
2. Check propeller shaft alignment.
3. Check remote control operating linkage is accurately adjusted to give correct travel on the gearbox operating lever.

7.4 Winter storage

Drain water from the transmission oil cooler to avoid freezing or the collection of harmful deposits.

7.5 Other maintenance operations

1. The gearbox oil should be changed at periods which correspond to the intervals at which engine oil changes are carried out.
2. The gearbox oil should also be changed if it has been contaminated by water or if the gearbox has suffered major mechanical damage.

8. FAULT FINDING

The fault finding chart overleaf is designed to help diagnose some of the problems which might be encountered. It assumes that the installation and operating instructions in this manual have been followed and we advise that these are checked before proceeding to fault finding.

To avoid prejudicing warranty rights, no repair or other work should be done on the gearbox during the warranty period without first contacting NEWAGE TRANSMISSIONS plc., COVENTRY, or an authorised distributor or dealer, for advice.

SYMPTOM	NOTICEABLE EFFECT	CAUSE	REMEDY
No oil pressure	No drive ahead or astern	Damaged oil pump	Remove oil pump and examine. If possible replace gears and shafts with repair kit. If body damaged replace complete unit.
		Broken input drive plate.	Replace drive plate.
Loss of drive		Oil leaks	Check for evidence of leakage and rectify.
Low oil pressure to both clutches	Propeller speed does not increase with engine speed ahead and astern	Damaged or worn oil pump	Repair with kit or replace.
		Remote control cable or linkage not allowing F-N-R lever to move correct distance	Remove cable and operate lever by hand. Adjust cable if necessary.
		Pressure relief valve spring defective	Remove valve block and replace spring.
Low oil pressure to one clutch	Propeller speed does not increase with engine speed in one direction only	Piston rings worn. Feeder worn	Remove appropriate clutch shaft Replace worn feeder or piston rings.
		Damaged 'O' ring in hydraulic circuit	Check 'O' rings in feeder connectors and piston.
		Blocked hydraulic passage in valve block	Remove valve block and examine.
		Damaged clutch plates	Remove and examine clutch on appropriate shaft and replace if necessary.
Gearbox noise	Excessive noise from gearbox	Input coupling defective	Remove, examine and replace if necessary.
		Gear rattle at low speed	Increase engine idling speed.
		Propeller shaft misalignment	Check the alignment of the propeller shaft coupling (see section 5.7); if necessary rectify by adjusting the shims under the engine mounts or the engine mounts themselves.
		Out-of-balance propeller	Remove the propeller and check that the pitch, weight, diameter and balance of all the blades are equal and rectify if necessary.
		Engine/gearbox misalignment	Remove the transmission and check that the flywheel face is flat and that the drive plate or flexible input coupling is correctly aligned.
		Defective bearing	Isolate defective bearing noise, remove and replace.
Excessively high oil temperature	Gearcase too hot to touch	Defective oil cooler	Replace oil cooler.
		Defective pressure relief valve	Remove and examine relief valve. Replace if necessary.
Gearbox oil consumption excessive	Oil level requiring constant topping up	Defective oil seal, gasket or 'O' ring	Clean the outside of the gearcase, particularly around the ends of shafts including the output shaft. Run the engine and observe the gearbox for leaks. Replace seals as required.
		Defective oil cooler	Check for traces of water in the gearbox oil or oil in the cooling water system. Replace cooler if necessary.
		Escape of high pressure in gearbox when dipstick is removed	Contact distributor or factory for advice.
Control lever on valve block stiff	Difficult to move single lever control	Defective valve or detent spring	Contact distributor or factory for advice.

9. SERVICING AND REPAIRS

The servicing, repair and replacement of components and assemblies on the input shaft and layshaft is made simple by the fact that the gearcase is constructed in two separate halves, the top half being easily removable to give access to the two top shafts.

This can be further simplified by fitting complete replacement shaft assemblies, and where skilled service personnel or reasonable workshop facilities are not readily available, or where time and labour costs are of greatest importance, it may be found advantageous to adopt this procedure.

Exploded views of all internal components are contained in the parts list. Many servicing operations can be carried out with the gearbox still mounted to the engine (provided, of course, that there is sufficient space in the engine compartment to allow this); examples are the replacement or repair of valve block and oil pump. It may also be possible to work on the layshaft and even the input shaft. The repair and maintenance of items on the output shaft will require that the gearbox is removed from the boat.

N.B. The input shaft and layshaft are supported by taper roller bearings. It will be necessary to recalculate the number of shims required to correctly load the bearings each time a shaft is stripped for inspection, component repair or replacement.

Shimming procedure is described in Section 9.10

9.1 Valve block

The complete valve block is easily removed for inspection and servicing with the gearbox still installed in the boat.

1. Disconnect the oil cooler pipes and the control cable or cables from the lever on the control equipment.
2. Disconnect the wiring from the neutral switch - if fitted.
3. Remove the 5 bolts and one nut which fix the valve block to the gearcase.
4. To remove the control valve and high pressure valve, simply remove the two cap screws (item no. C6) and withdraw the valves from the valve body. Care should be taken not to lose the detent ball and springs.
5. Inspect the 'O' ring (item no. C8) and bearing (item no. C10): replace if worn, damaged or defective. Check that the pressure relief valve spring (item no. C14) has retained its correct free length (64mm, 2.52 ins) and if not, replace.
6. To assemble and refit the valve blocks, simply reverse the above procedure.

9.2 Oil pump

The oil pump assembly can also be easily removed with the gearbox in situ.

1. Note the mounting position of the pump (for refitting).
2. Remove the four bolts securing the oil pump to the main case and withdraw the pump assembly complete with 'O' rings and shims.

3. Inspect the 'O' rings and replace if necessary. If in good condition carefully store until required for refitting.

If the oil pump is damaged in any way then the complete oil pump assembly (item No. B) must be replaced.

Note The clutch shaft must be reshimmed if a replacement pump assembly is fitted. If the old pump is re-used, refitting the original shims will be adequate.

9.3 Removing the transmission from the boat.

1. Ensure that the gearbox operating lever is in the neutral position and disconnect the operating cable or cables.
2. Drain the gearbox oil into a suitable container and disconnect oil cooler pipes.
3. Unscrew and withdraw the bolts connecting the gearbox output flange from the flexible coupling or mating half coupling on the propeller shaft.
4. Sling ropes around the gearbox to provide support while it is being removed from the engine.
5. Unscrew and withdraw the bolts securing the adaptor flange to the engine flywheel housing.
6. Slacken the bolts which secure the input coupling to the flywheel.
7. Withdraw the gearbox, if necessary by rocking the unit slightly in order to disengage the input shaft spline from the opposing spline in the coupling.

9.4 Removing the input shaft and layshaft assemblies

With normal installations, the layshaft assembly can be removed with the gearbox still installed in the boat, but the input shaft requires the gearbox to be removed from the engine. The procedure is as follows:

1. Drain the gearbox oil into a suitable container.
2. Disconnect oil cooler pipes and the cable from the gearbox control lever.
3. Remove the 4 bolts securing the oil pump to the gearcase and withdraw the oil pump, gasket, shims and 'O' rings, noting the position of the pump for refitting (note: keep pump shims with pump assembly).
4. Remove the 3 bolts securing the input shaft end cover and remove (note: keep shims and 'O' rings with the end cover).
5. Remove the 5 bolts and 1 nut retaining the valve block and remove.
6. Remove the 7 bolts securing the gearcase top half and lift clear.
7. Lift the layshaft assembly and front end cover from the gearcase.

The input shaft assembly requires to be removed using the following procedure:

1. Remove gearbox from boat as described in section 9.3.
2. Remove the 4 bolts securing the oil pump and withdraw the oil pump, gasket, shims and 'O' rings, noting the position of the pump for refitting (note: keep the pump shims with the pump assembly).
3. Remove the 3 bolts securing the input shaft end cover and remove. (note: keep shims and 'O' rings with end cover).
4. Remove 5 bolts and 1 nut retaining the valve block and remove valve block.
5. Remove 7 bolts securing the gearcase top half and lift clear.
6. Lift input shaft assembly, front seal housing and thrust washer from the gearcase.

9.5 Servicing Input Shaft and Layshaft Assembly Components

9.5.1 Input shaft oil seal

In the event of an oil leak due to a damaged seal, remove the input shaft oil seal housing from the shaft and with the aid of a hardwood drift and hammer, force the seal from the housing.

Fit a new seal (item D1) in the housing and refit the housing.

9.5.2 Drive end bearing

To renew a damaged or worn bearing, proceed as follows:

1. Support the shaft in a vice, and remove the input seal housing and thrust washer (this applies only to the input shaft).
2. Withdraw the clutch pinion, thrust washer, thrust bearing, and end bearing using pulley extractors with the jaws of the extractor located behind the pinion.
3. Refit the clutch pinion to the shaft.
4. Replace the thrust washer, and bearing, inspecting for wear and replacing where necessary.
5. Locate the new bearing (item D5) on the shaft and gently drive (either handpress or use hardwood drift and hammer) the assembly into position. Take care not to damage the bearing rollers or raceways during this operation.
6. Reposition the thrust washer, input seal housing on the shaft (input shaft only).

Note: If new bearings are fitted, the shaft must be shimmed as described in section 9.8.

9.5.3 Clutch assembly

Clutch plates which are discoloured by overheating, or worn down to the extent of having lost their grooving patterns, will tend to slip. If either of these conditions occur, the clutch assembly will need to be replaced as follows:

1. Remove the drive pinion and bearing as previously described.
2. Remove spacer, needle roller bearing, spacer, needle roller bearing.
3. Remove the large snap ring (D15).
4. Withdraw the complete clutch assembly from the shaft noting the position of the pull off springs and assembly pins.
5. Remove the small snap ring (D12), thrust bearing, and thrust washer and inspect for wear or damage and replace where necessary.

To rebuild the clutch assembly, the procedure is as follows:

6. Position shaft upright and locate the 3 assembly pins into the clutch gear.
7. Replace thrust washer, thrust bearing and the small snap ring.
8. Fit the clutch end plate (item D21) into the clutch gear and replace pull-off springs over the assembly pins. Then, starting with one of the driver clutch plates (item D20), build up the replacement clutch onto the clutch end plate.
9. Replace the clutch end cover (item D16) onto the clutch pack, locating the 3 pins and ensuring that one of the tapped holes in the clutch end plate aligns with the dimple on the body of the clutch gear.
10. Replace the large snap ring.
11. Replace the drive pinion into the clutch pack until it touches the bottom washer.
12. Replace needle roller bearing, spacer, needle roller bearing and spacer.
13. Replace the thrust bearing, thrust washer and bearing inner cone on the shaft and gently drive the bearing into position.

9.5.4 Drive pinion

If a drive pinion is worn or damaged it is advisable to renew both drive pinions simultaneously. To ensure that the drive pinion of the correct ratio is used please refer to the parts at the back of this manual. It is required to fit a ratio which is different to that which was originally supplied, the output gear as well as both pinions will need to be changed.

To replace the drive pinion, follow the procedure set out in section 9.6.2.

9.5.5 Rear end bearing, piston rings and feeder

1. Remove the rear end bearing and feeder using pulley extractors with the jaws of the extractor located behind the feeder.

2. Remove the piston rings from the shaft with the aid of a special piston ring extractor or a piece of thin steel. Raise one end of the top ring out of the groove and insert the steel strip between the ring and the shaft. Rotate the strip around the shaft applying slight forward pressure to the raised portion of the ring and until it rests on the land above the groove, where it can be eased off. Repeat this with the other two rings.
3. Take out the new rings from the packing and clean off any grease or inhibitor.
4. If a ring loading tool is available, fit this around the shaft, load the rings onto the tool and locate in their approximate position. Gently withdraw the tool and allow the rings to locate in their respective grooves.
5. Where a loading tool is not available use a thin metal strip, long enough to lay along the shaft above the grooves. Expand each ring just sufficiently to allow it to be placed in its approximate position over the strip. Gently withdraw the strip and locate the rings in their respective grooves. (see Fig. 14).
6. Compress each ring in turn and carefully fit the new feeders and bearing onto the shaft, and gently drive the bearing into position.

Note: It is advisable and strongly recommended that piston seals and tab washers should always be replaced.

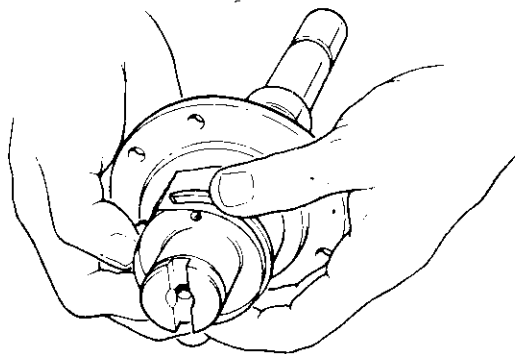

Fig. 14. Piston Ring Fitting Procedure

9.5.6. Clutch gear

The clutch gear is an interference fit on the shaft, and a power press is required to separate the gear from the shaft. Newage recommend therefore, that unless there is any damage to either the shaft or gear, the two are not separated.

Note: It is advisable to renew both clutch gears simultaneously since damage to one will often result in damage to its mating gear.

9.6 Replacement of input shaft and layshaft assemblies

1. Position the input shaft assembly in the gearcase and ensure that the thrust washer (D4) is correctly located in the groove in the lower half of the gearcase, and the seal housing is in the correct position, after examining the 'O' ring and oil seal, replacing if either are worn or damaged.
2. Position the layshaft in the gearcase and refit the end cover ensuring the 'O' ring is not worn or damaged, and the end cover is correctly located in the groove in the lower half of the gearcase.
3. Use a liquid gasket compound between the two case halves, and replace the top gearcase half, ensuring the feeder connectors are located correctly. To simplify the operation wire placed in the feeder connectors and passed through the holes in the top half of the gearcase will ensure they are approximately located when the gearcase top half is lowered onto them. The 'O' rings on the connectors should be examined for damage or wear and renewed if necessary.
4. Replace the two front gearcase bolts and ensure the gearcase halves are square.
5. Secure the remaining gearcase bolts tightening them to the correct torque.
6. Shim and refit the input shaft end cover, replacing the 'O' ring if damaged.
7. Shim and refit the oil pump replacing the 'O' ring if damaged. Ensure the oil pump is fitted in the correct position, to suit the direction of rotation required.
8. Refit the valve block, replacing the gasket.
9. Refit the bolts securing the adaptor plate to the gearbox.
10. Offer up the gearbox and the adaptor plate to the engine and secure.
11. Reconnect the oil cooler pipes and control cables.

Note: Shimming procedure is described in section 9.8

9.7 Servicing the output shaft assembly

Removal of the output assembly will necessitate removing the gearbox from the boat (see section 9.3). Then proceed as follows:-

1. Remove input shaft and layshaft assemblies as described in section 9.4.
2. Extract the split pin (F23) and slacken nut (F20) at the output coupling (F18), and remove coupling, washer (F19) and 'O' ring (F17).
3. Remove the output shaft end cover (F1), release tab washer (F4), slacken and remove retaining screws (F3), tab washer and bearing retaining washer (F5).
4. Remove four screws (F21) and remove rear seal housing (F15).
5. To remove the shaft, drive or press on the front end, the rear end bearings and oil seal can be removed leaving the front and centre components behind.

6. Having removed the output shaft from the gearbox, the output gear (F9) can be lifted from the gearcase.
7. Remove the circlip (F7) from the bearing bore and the bearing (F6) can be removed from its bore using a press or extractor pulleys.
8. Check both bearing and output gear for any defects or damage and replace if necessary.
9. If the oil seal (F16) is damaged, press out from seal housing (F15) and renew.
10. If the rear bearing (F13) is damaged, it can be removed from the shaft using either a press or pulley extractors.

Note: Whenever the output shaft assembly is stripped, it is always advisable to renew all 'O' rings, oil seal, tab washer and circlips.

To re-assemble the output shaft assembly:

11. Refit circlip (F12) correctly in the bottom of the gearcase.
12. Press rear bearing (F13) onto the shaft until it seats on the shoulder provided on the output shaft.
13. Assemble the shaft from rear. Feed spacer (F10), drive gear (F9) and spacer (F8) as it is pushed towards the input end.
14. Refit new 'O' ring (F14) and oil seal (F16) to oil seal housing (F15) and secure seal housing to the gearbox case, ensuring the housing is in the correct position so that it will not foul the input shaft end cover.
15. The circlip (F7) should now be refitted in its groove on the front bore and the front bearing (F6) pressed into position.
16. Refit bearing retaining washer (F5), tab washer (F4) and tighten screws (F3) to 11.7Nm (1.20 Kgfm - 8.61bf.ft), bend over tab washer and fit cover (F1) together with new 'O' ring (F2).
17. Refit the 'O' ring (F17), output coupling (F18), washer (F19) and nut (F20). Tighten nut to 340Nm (34.58 Kgfm - 250 lbf.ft).

9.8 Shimming procedures

The allowable end float on the taper bearing is 0.03 - 0.08mm (0.001 - 0.003in) clearance: this should be checked with the aid of a depth micrometer as follows:

1. Press the bearing outer cup firmly into position and measure between the face of the gearcase and the top of the bearing outer as shown in Fig. 15.
2. Measure the depth of the recess in the oil pump and in the output shaft end cover. Make up the difference with shims.

Where a depth micrometer is not available, the following method may be used:-

1. Remove the 'O' ring from the oil pump or end cover.
2. Fit sufficient shims so that the oil pump or end cover stands proud of the gearbox.

3. Rotate the input shaft or layshaft whilst slowly tightening the four securing bolts until the shaft starts to bind. Note: care must be taken to ensure that the oil pump or end cover is tightened squarely on to the gearbox face: this can be checked by feeler gauges or shims around the pump end cover to ensure a uniform gap.
4. Now measure the gap with the aid of feeler gauges or shims. Deduct shims to this figure plus 0.05mm (0.002in) from the shims already installed.
5. Remove the necessary number of shims, tighten the oil pump or end cover, and test by rotating the shaft.
6. Remove the oil pump or end cover and refit with the 'O' ring installed.

Note: Shims are available in two thicknesses, 0.254mm (0.010in) and 0.05mm (0.002in). As an example of their use, if an end float reading of 0.548mm (0.023in) is obtained, two shims of 0.254mm (0.010in) and one of 0.05mm (0.002in) should be used, giving a final end float or clearance of 0.025mm (0.001in).

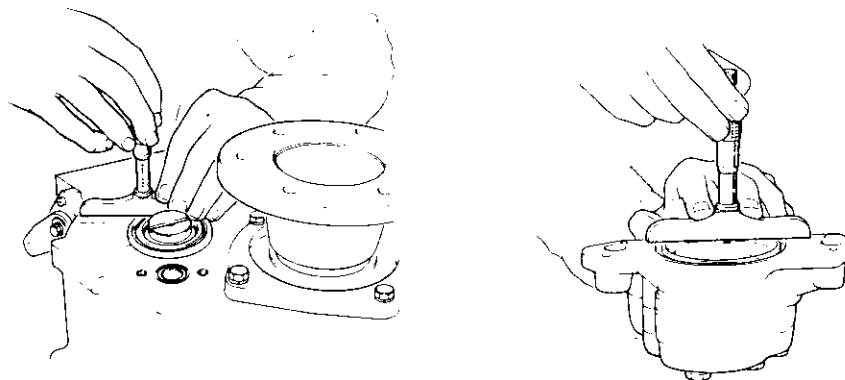

Fig. 15. Shimming Procedure

10. POWER TAKE-OFF UNIT

10.1 To fit a P.T.O. unit to an existing gearbox

1. Remove end cover (A10) from rear face of gearbox, taking care not to lose shims, and replace shims against bearing outer race. (Use grease if required).
2. Fit spacer (H5) and drive gear (H4) to end of splined shaft, which protrudes from rear of gearbox.
3. Fit spacer (H7) into recess in gear and locking tab into hole in face of the gear.
4. Tighten screw (H9) to 101.5 Nm (10.35 Kgfm - 75 lbf.ft) and bend up locking tab.
5. Pass the P.T.O. unit over the gear (H4) and push against rear face of gearbox, ensuring that shims do not drop down and are located in recess in P.T.O. housing. Also ensure that 'O' ring remains in groove in P.T.O. housing and does not become trapped.
6. Tighten bolts (H11) into rear face of gearbox to 101.5 Nm (10.35 Kgfm - 75 lbf.ft).
7. Fit oil pipe assembly (H23) as shown on the installation drawing, between the 'T' piece on the P.T.O. housing and the connector on the valve block.
8. Fit hydraulic pump to P.T.O. unit.

10.2 To repair an existing P.T.O. unit

1. Removal of the unit is the reverse of that described in (10.1) above.
2. The output gear assembly (H2) can be removed without removing the P.T.O. unit from the gearbox. Remove hydraulic pump from P.T.O. and slacken screws (H19/H20). Pull out housing (H13/J13) and the gear (bearing assembly will remain with the housing).
3. To remove the output gear, (H2) remove circlip (H21) and tap gear on the end face to remove from bearing (H12).
4. The bearing (H12) can be removed by removing circlip (H15) and pressing or drifting out bearing.
5. If needle bearing (H3) is worn or damaged, it is best replaced when the P.T.O. housing is removed from the gearcase.
6. If the drive gear (H4) is removed from the gearbox shaft, then tab washer (H8) MUST be replaced.
7. Assembly is the reverse of all above and that described in (10.2) above.

11. 8° DOWN-ANGLE DRIVE UNIT

11.1 Retrofitting unit to an existing PRM 302 gearbox

1. Remove the gearbox from the engine and separate from the adaptor plate as previously described.
2. Withdraw the output shaft front cover (F1) and input shaft seal housing (D2).
3. The output shaft cover (F1) must be replaced by spacer (G11) supplied with the angle drive unit. The spacer (G8) at the "top" of the angle drive locates in the front bore of the main gearbox.
4. Remove the oil pump assembly, turn through 180° and bolt in position, ensuring that the 'O' ring remains in its groove and the shims remain in the pump recess.
5. Grease gasket (G9) and fit to the front face of the main gearbox. Offer the angle drive up to the main gearbox, locate the splined shaft and tighten bolts (G10/G12) to 101.5 Nm (10.35 Kgfm - 75 lbf.ft).
6. Screw the metering union (G19) into the top of the angle drive, fit 'T' piece (G21) and oil pipe, (G20).
(see circuit and piping diagrams).
7. Connect the other end of the oil pipe to the fitting on the valve block.
8. Bolt the adaptor to the front face of the angle drive. Tighten bolts to 101.5 Nm (10.35 Kgfm - 75 lbf.ft).
9. Fit new dipstick to main gearbox and fill with oil.

Note: When an angle drive unit is fitted, the gearbox output rotation will be reversed. It is therefore necessary to reverse the control lever movement to give correct output rotation for 'ahead' or 'astern'.

11.2 Replacement of angle drive gears and bearings

1. Remove the unit from the main gearbox, as the reverse of that described in (11.1) above.
2. Remove bolt (G3) (1 off) and insert withdrawal screws to split the 2 halves of the gearcase.
3. Remove input seal housing (G17) and shims; also remove spacer (G8) and shims at the output gear rear face.

Note: Take care not to mix the input and output shims.

4. All bearings and gears are now free for "inspection". If damage or wear has taken place on any bearing, then it is recommended that all four are replaced. Also, the gears should be inspected if bearing wear has taken place. If gear replacement is required, it is advisable to replace both.
5. The bearing outer races can be easily pulled out of the housing, but a puller will be required to remove the inner races from the gears.

6. To re-assemble the unit, assuming new bearings and/or gears, first press the bearing inner races to the gears and push the outer races into the housing halves.
7. Locate the input gear on the rear case half and the output gear on the front half.
8. Coat the mating faces on the case-halves with "jointing" compound and bring the two halves together, ensuring dowels (G6) are properly located.
9. Tighten bolts (G3) (G12) to a torque of 101.5 Nm (10.35 Kgfm - 75 lbf.ft).
10. To shim input shaft bearings, proceed as follows:-

Note: Shimming is best done prior to fitting oil seal (G18) or 'O' ring; (G16) and with the unit horizontal on a flat surface.

- a) Push in seal housing (G17) against bearing outer race.
 - b) Apply hand pressure to spacer or place a weight of approximately 5 Kg on top of the spacer and turn shaft to seat the bearings.
 - c) Measure "step" between gearcase face and lower face of the housing with a depth micrometer or vernier.
 - d) Lift out housing and place shims of the value found in (c), below the housing.
 - e) Fit seal and 'O' ring to the housing and replace.
11. The output shaft bearings can be shimmed as follows:-
 - a) On a similar basis to the input shaft, apply hand pressure or a weight to the spacer, (G8) which is already located in the output bore.
 - b) Rotate the shaft to seat the bearings and measure the gap between the face of the gearcase and the face of the spacer which is just below the gearcase face. (Use a depth micrometer or vernier as before).
 - c) Lift out spacer, insert shims to value found in (b) and replace the spacer.
 12. Refit the angle drive onto to the main gearbox as described in the section on "retrofitting".

12. IN-LINE GEARBOXES

Unlike the angle drive unit, the in-line gearbox has a factory fitted in-line unit and CANNOT be retro-fitted. Servicing and repair of the main gearbox is the identical to servicing a standard drop-centre gearbox. Servicing the in-line unit is as follows:

12.1 In-line unit removal

1. Disconnect oil pipes connecting in-line unit to both the cooler and the main gearbox.
2. Remove bolts (K21 - 3 off), (K23 - 2 off) and (K24 - 2 off), and split the two case halves of the in-line unit.
3. The two gears (K7 and K14) can now be removed from the rear case half.
4. To detach the rear case half from the main gearcase, remove the cap screw (K15) and four bolts (K17). When detaching the rear case half, care should be taken not to misplace the spacer and shims from both shafts.

12.2 Inspection, renewal and shimming

1. All bearings and gears are now free for inspection for damage or wear. If a gear requires replacing, it is advisable to replace both.
2. The bearing outer races can be easily pulled out of the housings, but a puller or press will be required to remove the inner races from the gears.
3. Before the in-line unit can be reassembled and secured to the main gearbox it is essential that the two shafts be shimmed. The procedure is as follows:
4. Push the bearing outer races into the in-line case halves and fit the bearing inner races onto the gear/shafts.
5. Fit the two case halves together and secure with bolts (K21 and K24).
6. Using a depth micrometer measure the depth from the front face of the main gearcase to the thrust washer on the input shaft.
7. Ensuring that the outer races on the two rear bearings are correctly located in the rear in-line case half, measure the distance from the bearing to the rear face of the in-line case.
8. Subtract the value of 11 from 10, and the result is the amount which needs shimming. The shim tolerance is size to -0.002 " (0.05mm).
9. To shim the output shaft on the main gearbox place the spacer (K12) in the bore of the main gearbox case (output shaft) and using a depth micrometer, measure the distance from the front face of the main gearcase to the face of the spacer.
10. With the lower rear bearing outer race correctly located in the rear case of the in-line unit, measure the step between the face of the rear case half and the outer race, seated in the bore.
11. The result of 14 plus 13 is the value of the shims required with a tolerance of size -0.002 in (0.05mm).

12.3 In-line unit rebuild

1. Having completed the shimming process the in-line unit can now be refitted to the main gearbox, as follows:
2. Locate the correct amount of shims in both input and output shaft bores on the main gearcase.
3. Fit the spacer (K12) in the output shaft bore of the main gearcase.
4. Offer the rear case half (complete with outer bearing races) of the in-line unit to the main gearcase, and secure with bolts (K17) and cap screw (K15).
5. Refit the two gears (K7 and K14), together with the bearing inner races, into the rear case half of the in-line unit.
6. The front case half and bearing cups can now be secured to the rear case half using bolts (K21, K23 and K24).
7. Press the oil seal (K22) into the bore, taking care not to damage the seal.
8. Reconnect oil pipes to cooler and main gearbox.

13. TIGHTENING TORQUES

	Nm	lbf.ft	Kgfm
Upper to lower gearcase bolts	56.0	40.3	5.71
Top cover to upper gearcase	28.0	20.6	2.86
Pump cover to pump body	28.0	20.6	2.86
Pump body to gearcase	56.0	40.3	5.71
Operating lever to selector valve	28.0	20.6	2.86
End plate to valve block	9.4	6.9	0.96
Valve block to upper gearcase	28.0	20.6	2.86
Upper/lower gearcase : stud	39.2	28.9	4.00
nut	56.0	40.3	5.71
End cover to gearcase	98.0	72.3	10.00
Oil seal housing to gearcase	56.0	41.0	5.71
Output bearing retaining bolts	11.7	8.6	1.20
Coupling to output shaft	340.0	250.0	34.69
Adaptor plate to gearcase : bolt/nut	98.0	72.3	10.00
stud	68.6	50.6	7.00
P.T.O. to rear gearcase	98.0	72.3	10.00
In-line case halves	98.0	72.3	10.00
In-line rear gearcase to main gearbox	98.0	72.3	10.00
Angle drive case halves	98.0	72.3	10.00
Angle drive to front gearcase	98.0	72.3	10.00

SPARE PARTS ORDERING

When ordering spare parts the following should be quoted:

- a) Gearbox model and serial number
- b) Description(s) and part number(s) of the component(s) required
- c) Quantity required

NOTES

- 1 Individual items which form part of an assembly, or main components, are indented and may be supplied separately; if the assembly is ordered all components pertaining to that assembly are supplied. For example, if the 'clutch input shaft' assembly is ordered the shaft itself and every item called up and shown on the corresponding illustration will be supplied, with the exception of the end housing and oil seal. The same applies to the layshaft.
- 2 Clutch plate assemblies, i.e. end plates, driven plates and driver plates are supplied in sets.

Orders and enquiries for spare parts should be addressed to:

NEWAGE TRANSMISSIONS plc
BARLOW ROAD
COVENTRY CV2 2LD
ENGLAND

Tel: 0203 617141 Telex: 31333 Cables: 'SUPAGEARS' Coventry
Fax: 0203 611845

Spare Parts List

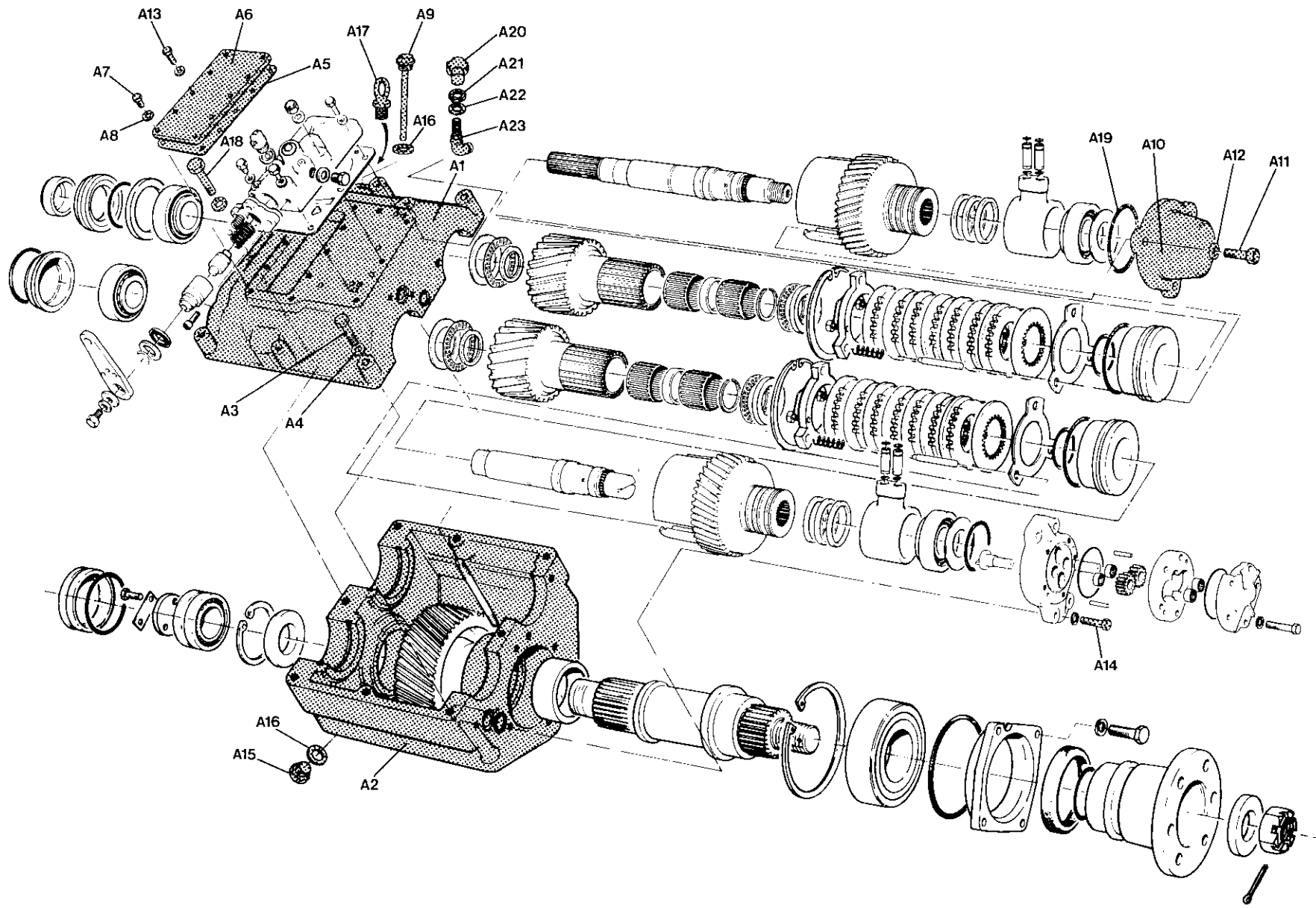

PRM302

Plate Ref.	Description	Part No.	Qty.	Remarks
A	GEARCASE ASSEMBLY			
	Case sub-assembly	MT0316	1	Supplied complete only Not supplied separately Not supplied separately
A1	Gearcase - top	MT1517	1	
A2	Gearcase - bottom	MT1530	1	
A3	Bolt	0041014	6	
A4	Washer	0191710	11	
A5	Gasket (top cover)	MT343	1	
A6	Top cover	MT1467	1	
A7	Screw	0040804	10	
A8	Washer	CP1223	10	
A9	Dipstick	MT472	1	
A10	End cover	MT1267	1	
A11	Screw	0041208	3	
A12	Washer (spring)	0191107A	3	
A14	Bolt	0041010	4	
A15	Drain plug	CP1331	1	
A16	Washer (dipstick)	CP1068	2	
A17	Eyebolt	CP1339	1	
A18	Bolt	0041019	1	
A19	'O' Ring	0430771	1	
A20	Breather	CP1383	1	
A21	Locknut	CP1385	1	
A22	Washer	CP1204	1	
A23	Breather tube assembly	cp1382S/A	1	

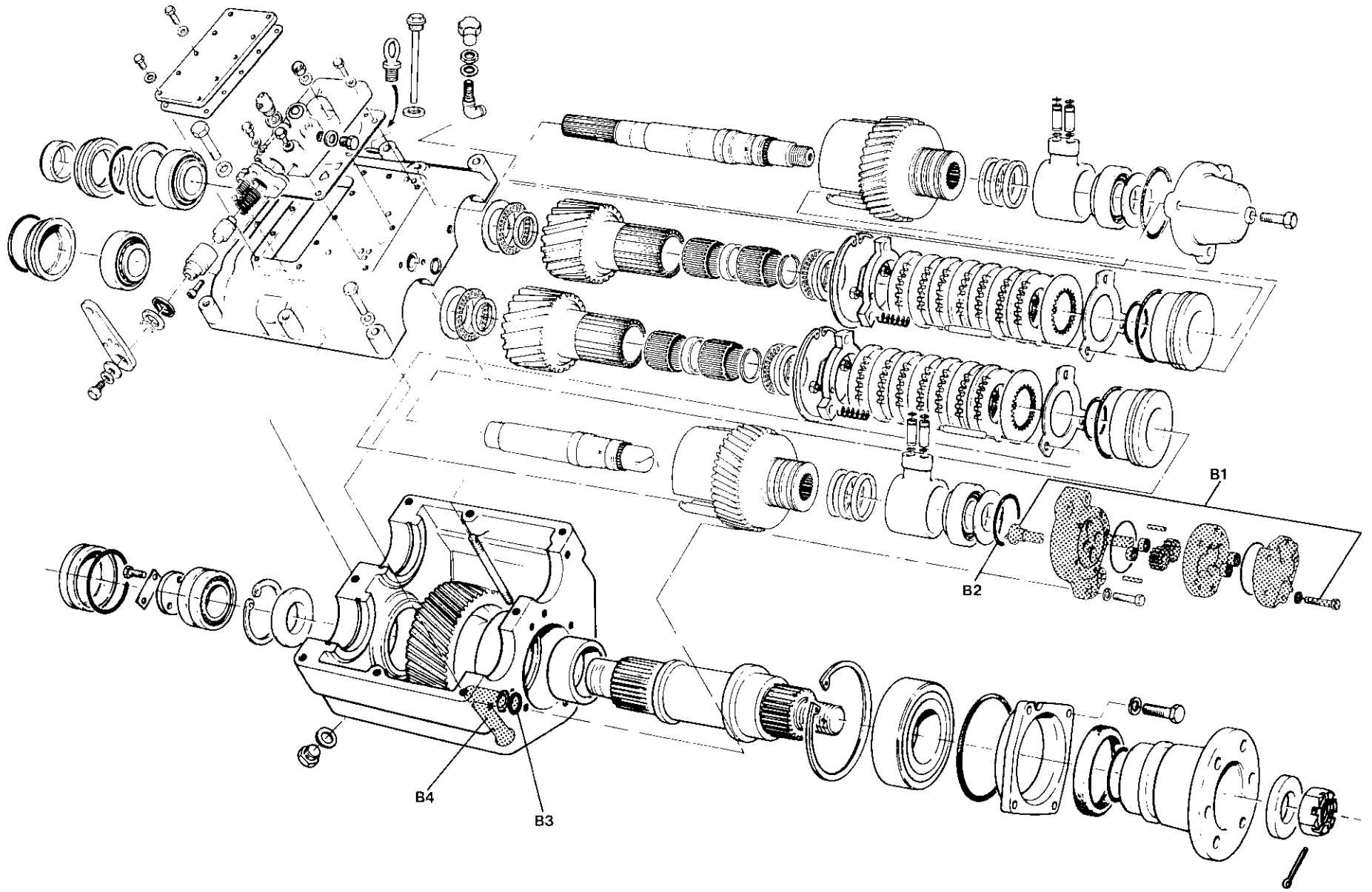

PRM302

Plate Ref.	Description	Part No.	Qty.	Remarks
B	OIL PUMP ASSEMBLY		1	
B1	Oil pump assembly	MT0294	1	
B2	'O' ring	003383	1	
B3	'O' ring	001254	1	
B4	Oil pipe	MT736	1	

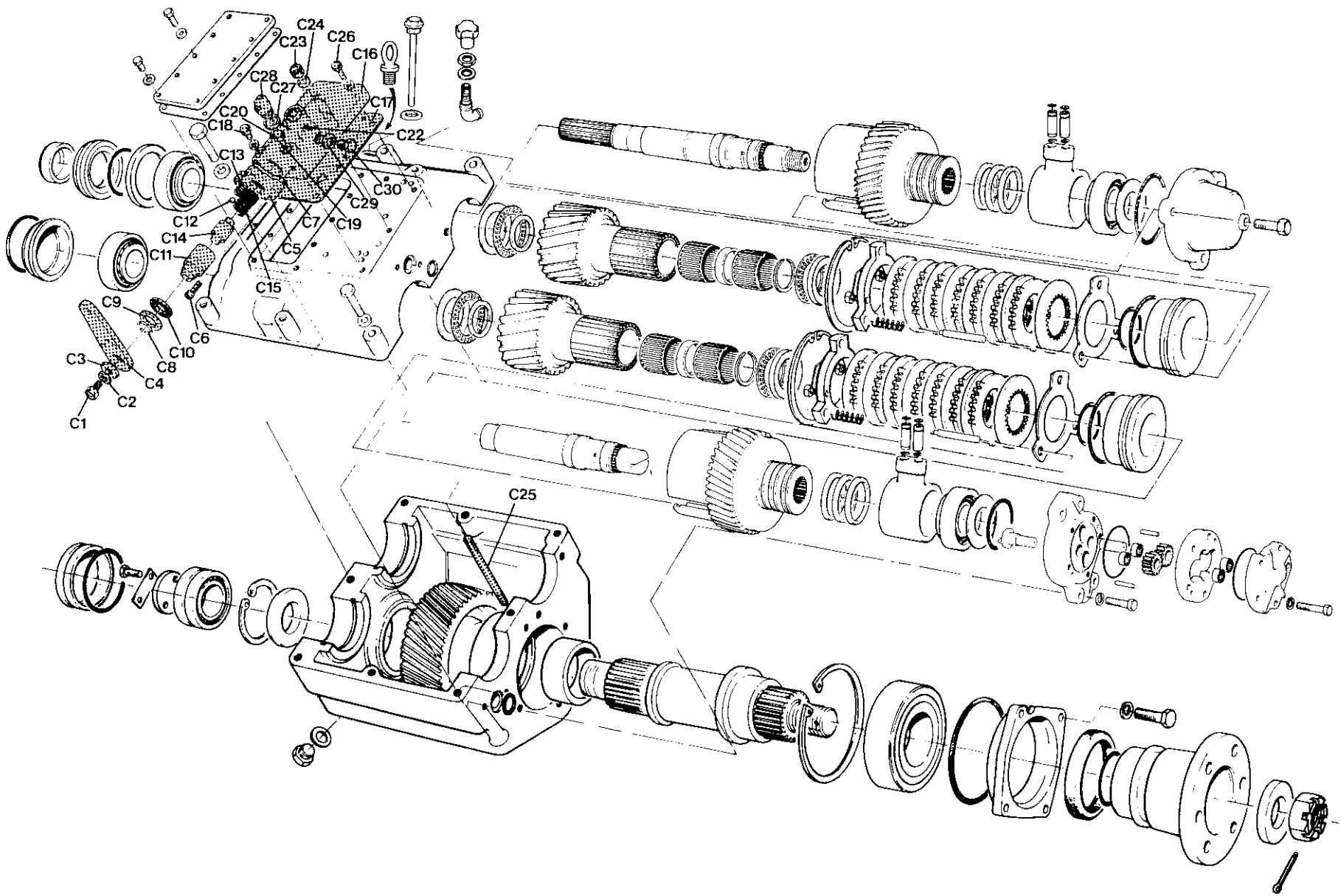

PRM302

Plate Ref.	Description	Part No.	Qty.	Remarks
C	VALVE BLOCK ASSEMBLY	MT0011	1	
C1	Screw	0040806	1	
C2	Spring washer	0191105	1	
C3	Washer	MT979	1	
C4	Operating lever	MT977	1	
C5	End plate	MT978	1	
C6	Cap screw	0081220	2	
C7	Gasket	MT1081	1	
C8	O ring	000753	1	
C9	Thrust race	CP1308	1	
C10	Thrust bearing	CP1307	1	
C11	Control valve	MT4656	1	
C12	Detent ball	CP1077	1	
C13	Detent spring	MT305	1	
C14	Relief valve	MT980	1	
C15	Valve spring	MT1194	1	
C16	Valve block	MT4739 -	1	
C17	Gasket	MT1073	1	
C18	Bolt	0040812	1	
C19	Washer	CP1223	5	
C20	Bolt	0040815	1	
C22	Pressure plug	MT311	1	
C23	Nut	0051001	1	
C24	Washer	0191710	1	
C25	Stud	MT1292	1	
C26	Screw	0040808	3	
C27	Washer	0201715	1	
C28	Plug	CP1360	1	
	or			
C28	(Switch	CP1358	1	
	(Ball	CP1077	1	
C29	Washer	0191718	1	
C30	Plug (M18 pressure port)	0150318	1	

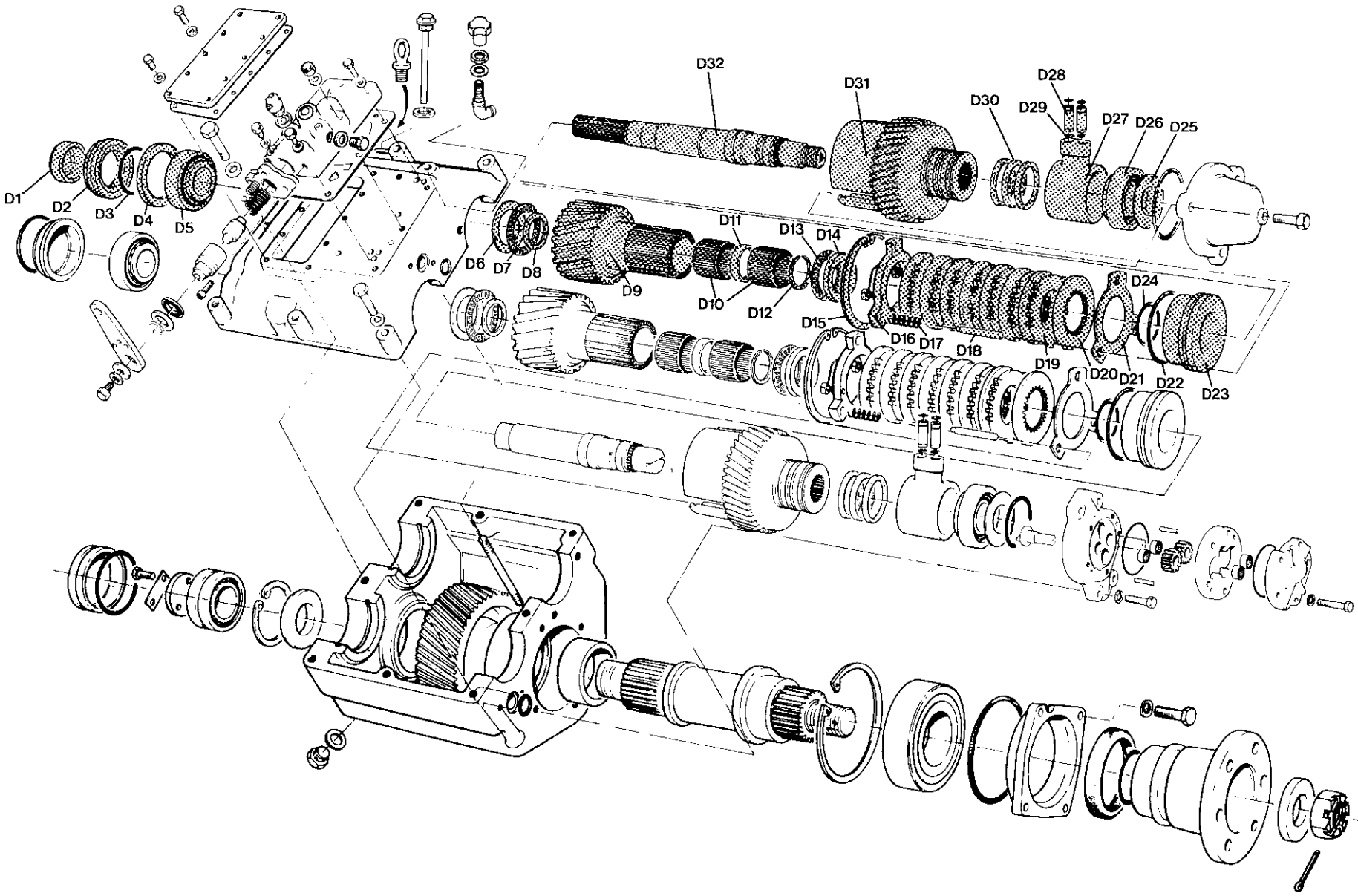

PRM302

Plate Ref.	Description	Part No.	Qty.	Remarks	
D	INPUT SHAFT ASSEMBLY				
D1	Oil seal	MT251	1	Not used when angle drive is fitted	
D2	Oil seal housing	MT1514	1		
D3	'O' ring	04306725	1		
D4	Thrust washer	MT1516	1		
D5	Bearing .	055U044	1		
	Bearing cup	055C019	1		
D6	Thrust washer	0673801	1		
D7	Thrust bearing	0603801	1		
D8	Spacer	MT1471	1		
D9	Pinion	MT1474	1	1.5:1 37 Teeth	
		MT1475	1		2:1 31 Teeth
		MT1476	1		2.5:1 23 Teeth
		MT1477	1		3:1 21 Teeth
D10	Needle roller bearing	0563501	2		
D11	Spacer	MT1472	1		
D12	Snap ring	0300350	1		
D13	Thrust bearing .	0603501	1		
D14	Thrust washer	0673503	1		
D15	Circlip	0251020	1		
D16	Clutch end cover	MT1484S/A	1		
D17	Spring	MT1067	3		
D18	Assembly pin	MT1485	3		
D19	Clutch plate - driven	MT982	7		
D20	Clutch plate - driver	MT725/S	8		
D21	End plate	MT983	1		
D22	Piston 'O' ring	003504	1		
D23	Piston	MT1264	1		
D24	Piston 'O' ring	0421503	1		
D25	Shims		1	Order kit MT0068	
D26	Bearing .	0540302	1		

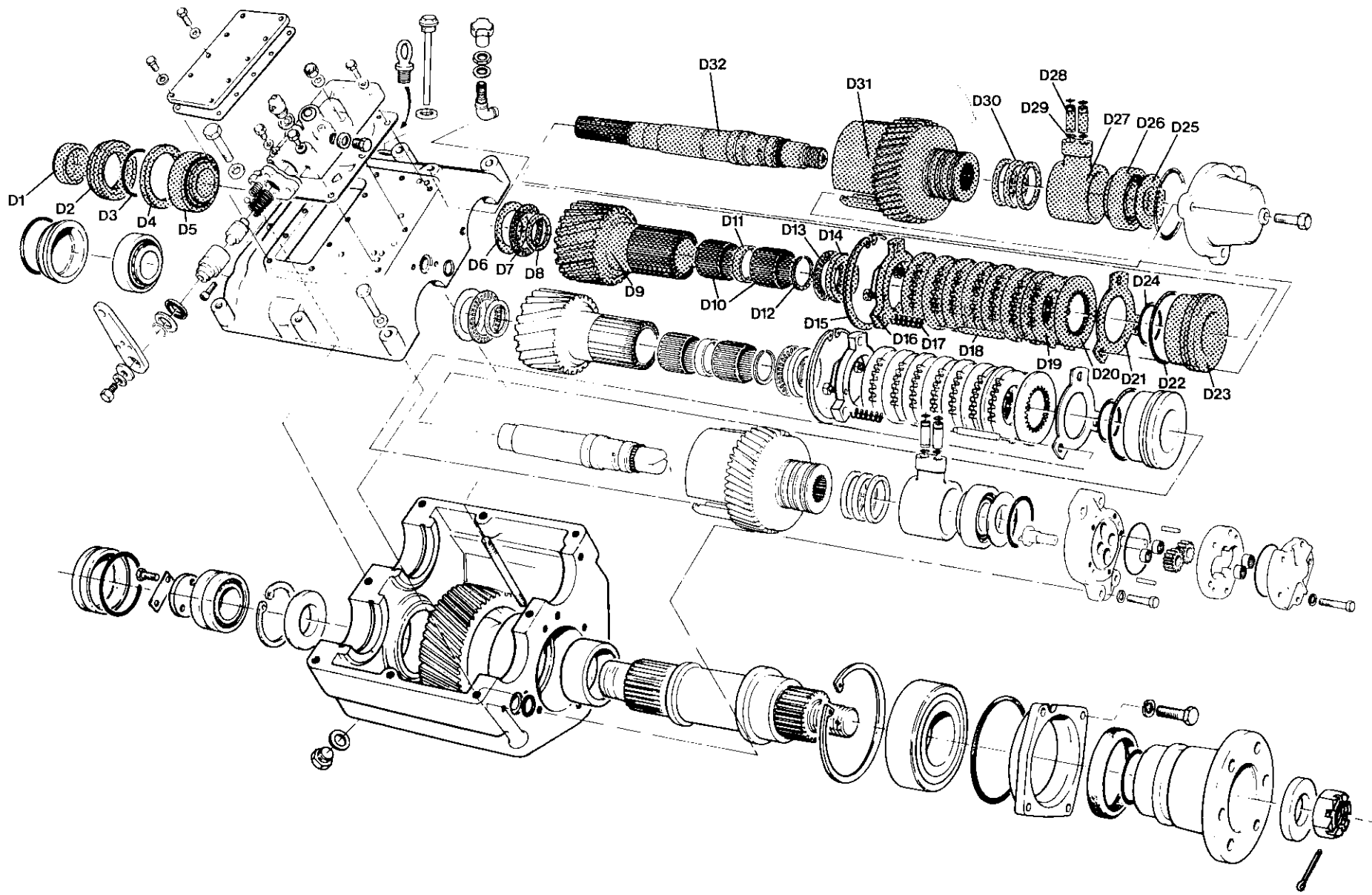

PRM302

Plate Ref.	Description	Part No.	Qty.	Remarks
D27	Feeder	MT380	1	
D28	Feeder connector	MT1057	2	
D29	Feeder 'O' ring	000372	4	
D30	Piston ring	MT292	3	
D31	Clutch gear	MT1483	1	
D32	Input shaft	MT1482	1	

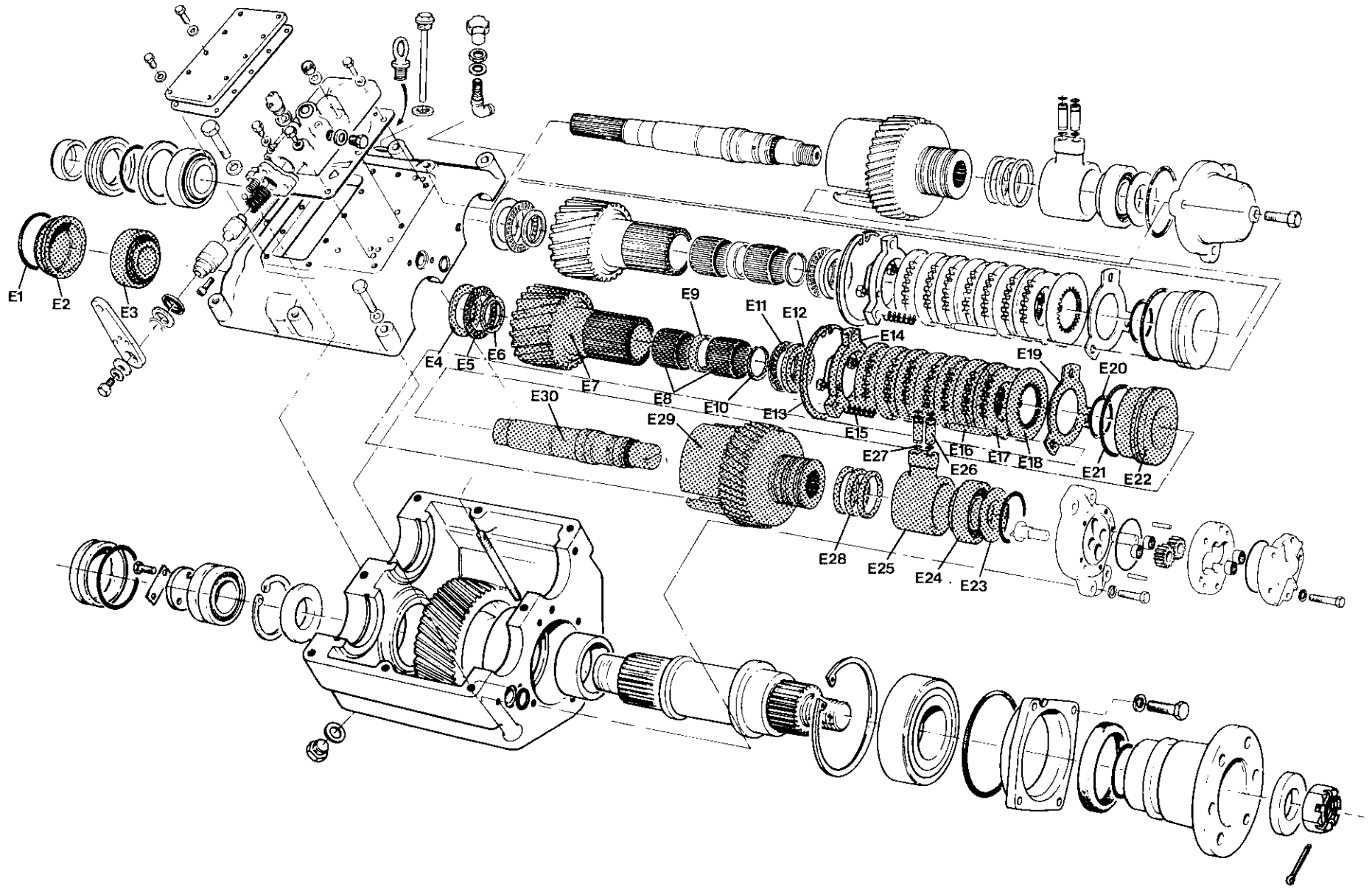

PRM302

Plate Ref.	Description	Part No.	Qty.	Remarks
E	LAYSHAFT ASSEMBLY			
E1	'O' ring	04306725	1	
E2	End cover	MT1515	1	
E3	Bearing	055U044	1	
	Bearing cup	055c019	1	
E4	Thrust washer	0673801	1	
E5	Thrust bearing	0603801	1	
E6	Spacer	MT1471	1	
E7	Drive Pinion	MT1474	1	1.5:1 37 Teeth
		MT1475	1	2:1 31 Teeth
		MT1476	1	2.5:1 23 Teeth
		MT1477	1	3:1 21 Teeth
E8	Needle roller bearing	0563501	2	
E9	Spacer	MT1472	1	
E10	Snap ring	0300350	1	
E11	Thrust bearing	0603501	1	
E12	Thrust washer	0673502	1	
E13	Circlip	0251020	1	
E14	Clutch end cover	MT1484S/A	1	
E15	Spring	MT1067	3	
E16	Assembly pin	MT1485	3	
E17	Clutch plate - driven	MT982	7	
E18	Clutch plate - driver	MT725/S	8	
E19	End plate	MT983	1	
E20	Piston O ring	0421503	1	
E21	Piston O ring	003504	1	
E22	Piston	MT1264	1	
E23	Shims		1	Order shim kit MT0068
E24	Bearing	0540302	1	
E25	Feeder	MT380	1	
E26	Feeder connector	MT1057	2	

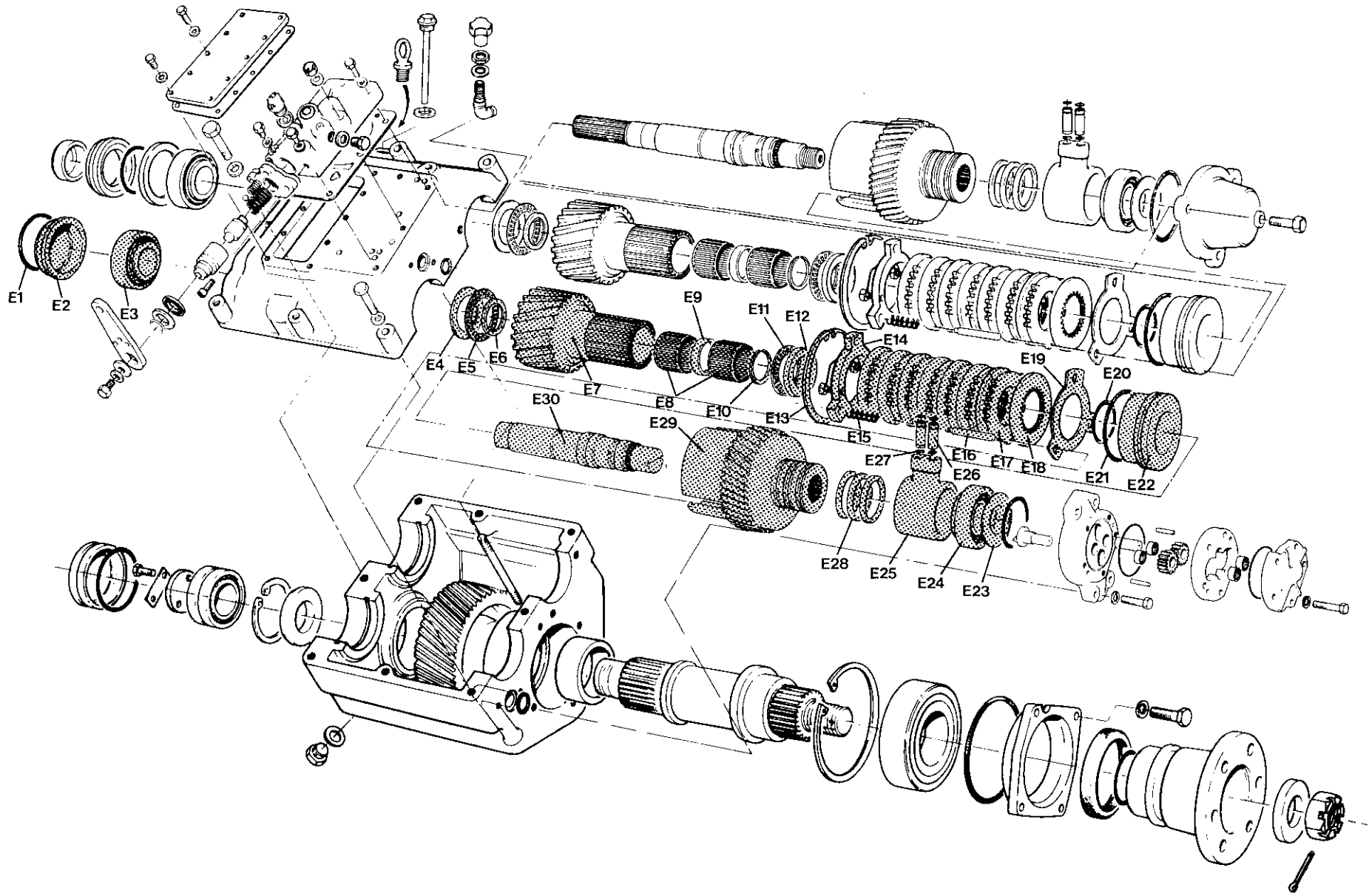

PRM302

Plate Ref.	Description	Part No.	Qty.	Remarks
E27 E28 E29 E30	Feeder 'O' ring Piston ring Clutch gear Layshaft	000372 MT292 MT1501 MT1500	4 3 1 1	

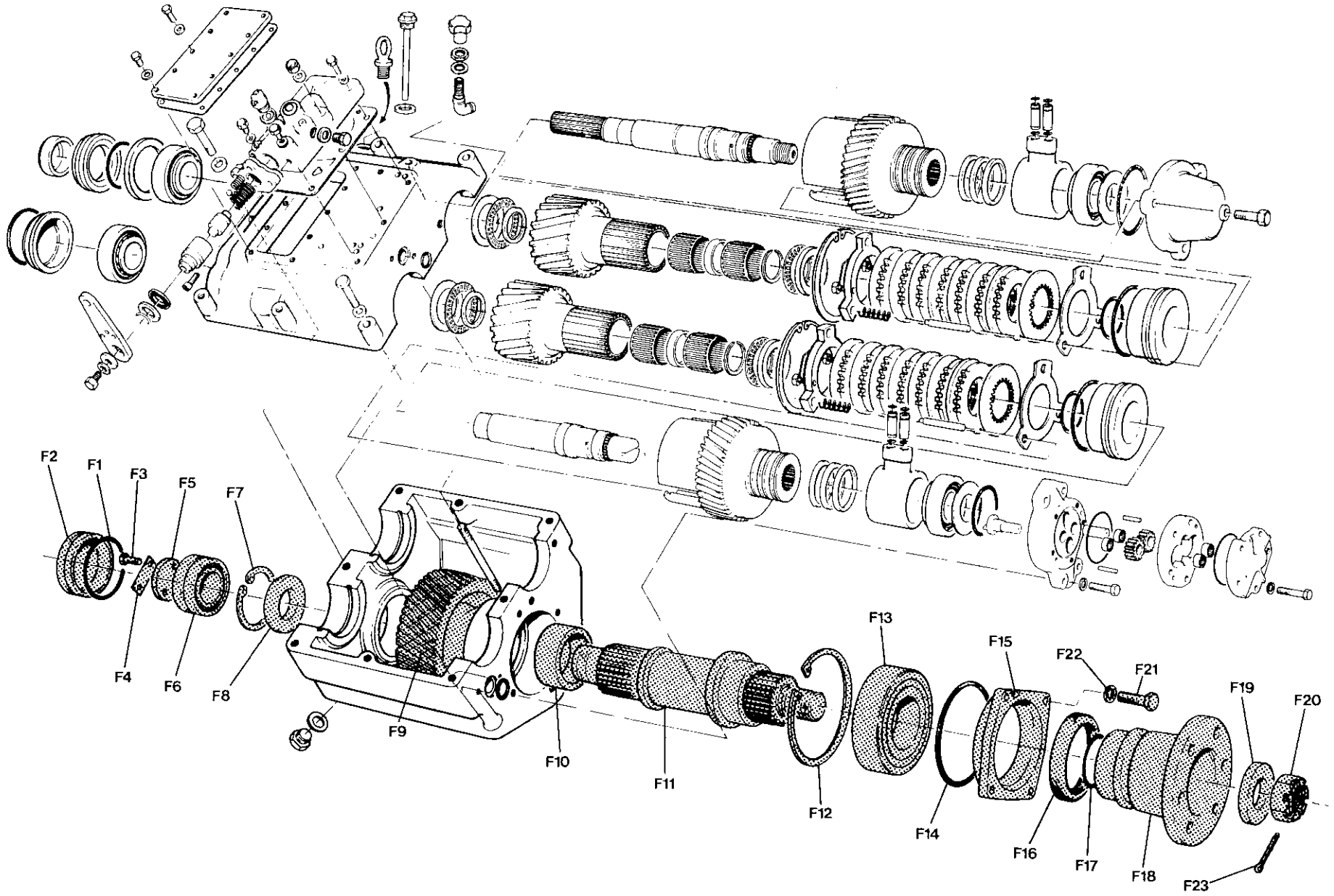

PRM302

Plate Ref.	Description	Part No.	Qty.	Remarks
F	OUTPUT SHAFT ASSEMBLY			
F1	End cover	MT1529	1	
F2	O ring	002433	1	
F3	Screw	0040607	2	
F4	Special tab	MT986	1	
F5	Bearing retaining washer	MT984	1	
F6	Needle bearing	0564001	1	
F7	Circlip	0250620	1	
F8	Spacer	MT897	1	
F9	Output gear 1.459:1	MT1064	1	54 teeth.
F9	1.935:1	MT1254	1	60 teeth.
F9	2.565:1	MT1419	1	59 teeth.
F9	2.904:1	MT1316	1	61 teeth.
F10	Spacer	MT717	1	
F11	Output shaft	MT1423	1	
F12	Circlip	CP1194	1	
F13	Bearing	MT451	1	
F14	O ring	004754	1	
F15	End cover	MT1424	1	
F16	Oil seal	MT252	1	
F17	O ring	002123	1	
F18	Output coupling	MT755	1	
F19	Washer	MT1251	1	
F20	Nut	MT1488	1	
F21	Screw	0041009	4	
F22	Spring washer	0191106	4	
F23	Split pin	024M345	1	

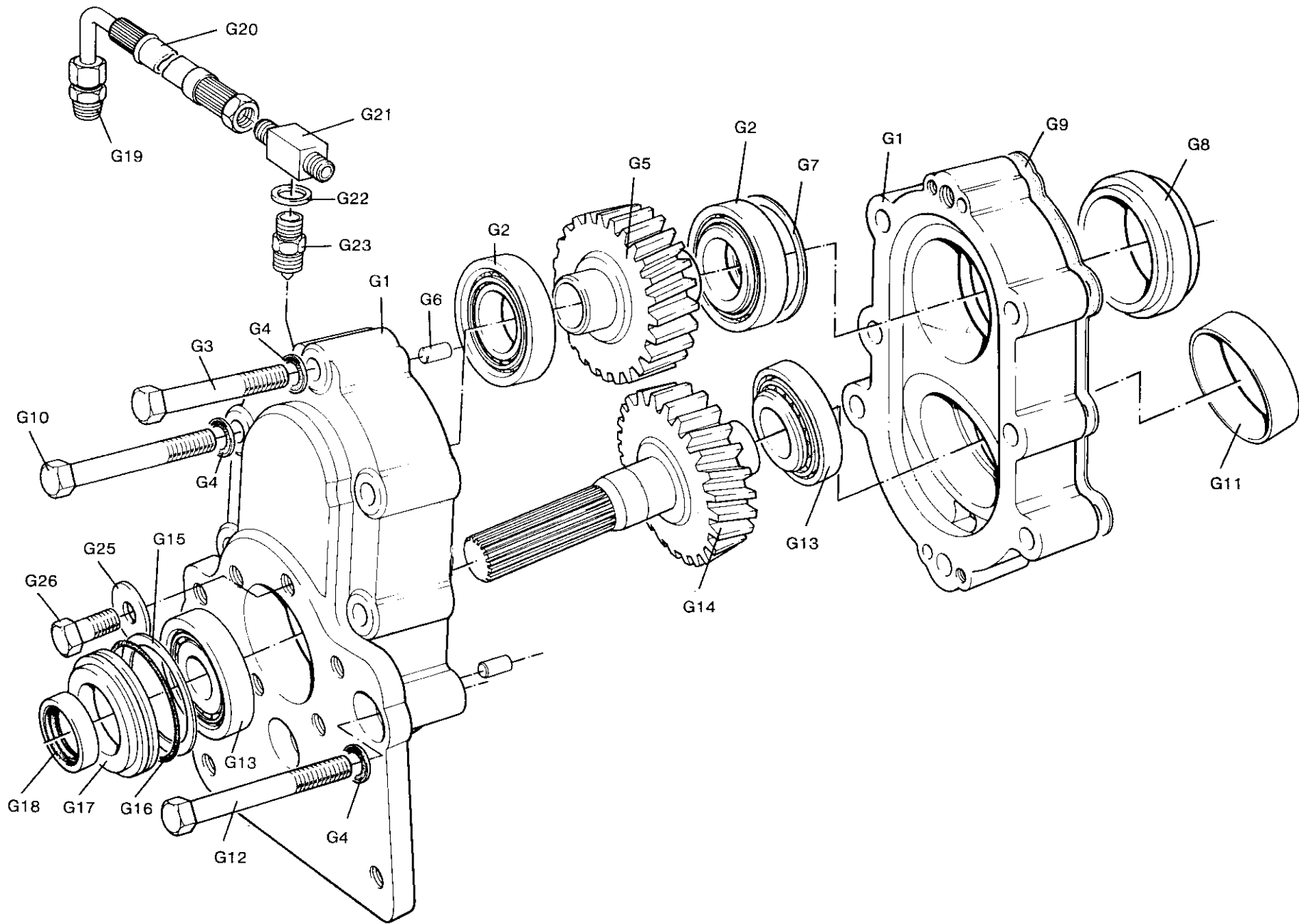

PRM302

Plate Ref.	Description	Part No.	Qty.	Remarks
G	ANGLE DRIVE UNIT	MT0210		
G1	Gearcase S/A	MT0189	1	
	Half case (front)	MT1273	1	Not supplied separately
	Half case (rear)	MT1274	1	Not supplied separately
G2	Taper roller bearing	0540351	1	
G2A	Taper roller bearing	0540353	1	
G3	Bolt	0041216	1	
G4	Dowty seal washer	CP1204	8	
G5	Output gear	MT1320	1	MT1527 after Nov.'87
G6	Dowel	0210815	2	
G7	Shim	057313A/C/E	AR	
G8	Location ring	MT1512	1	
G9	Gasket	MT1281	1	
G10	Bolt	0041222	4	
G11	Spacer	MT1439	1	
G12	Bolt	0041221	3	
G13	Taper roller bearing	0540302	2	
G14	Input gear	MT1319	1	MT1525 after Nov.'87
G15	Shim	MT1077	AR	
G16	O ring	002874	1	
G17	End cover	MT1068	1	
G18	Oil seal	MT251	1	
G19	Adaptor	CP1255	1	
G20	Oil pipe	MT766	1	
G21	Tee piece	CP1367	1	
G22	Washer	0201715	1	
G23	Metering union	MT4583	1	
G24	Dipstick	MT472	1	Not illustrated
G25	Washer	CM2123		Transit only
G26	Screw	0041206		Transit only
G27	Nut	0051205	2	Not illustrated transit only

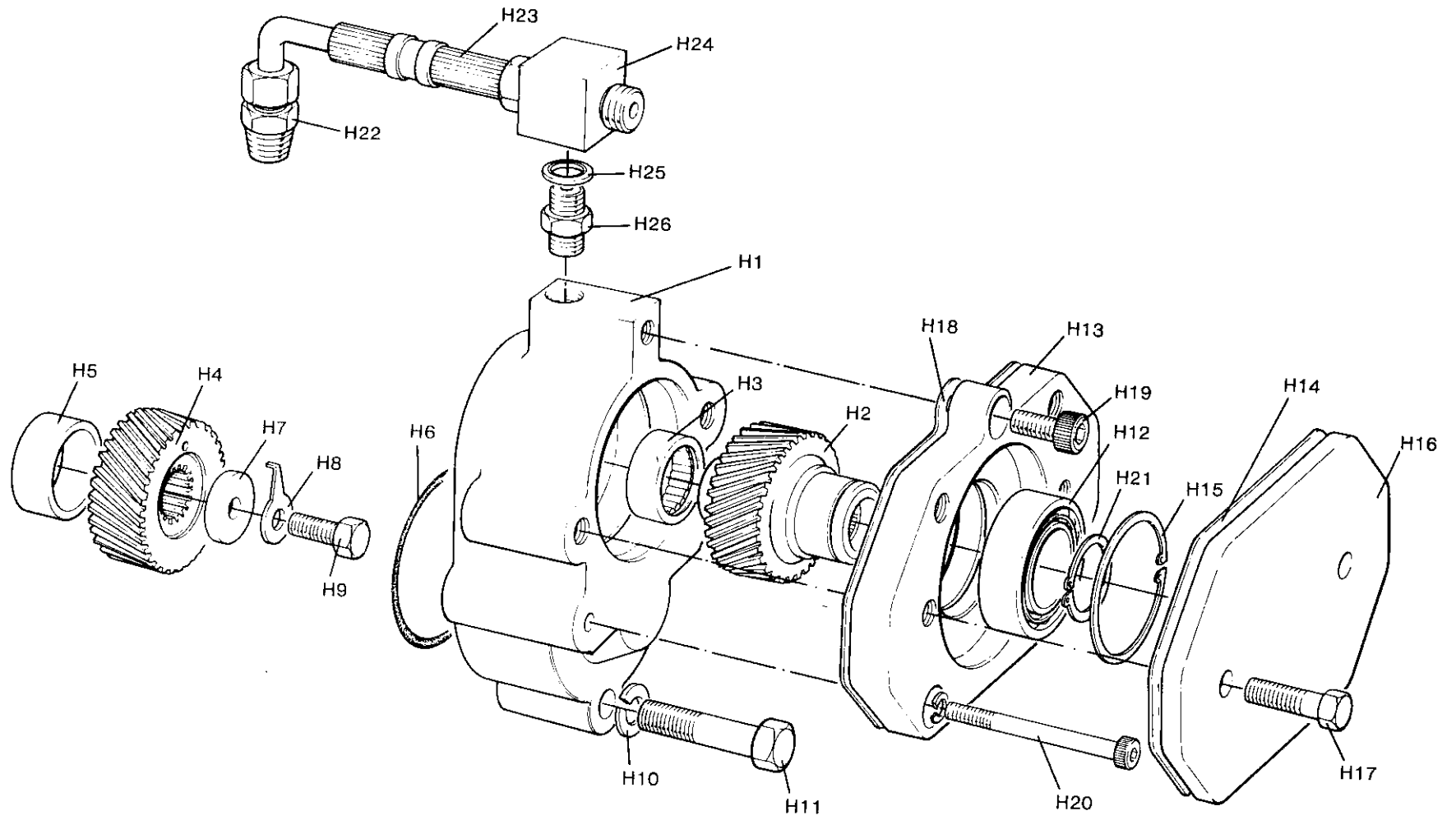

PRM302

Plate Ref.	Description	Part No.	Qty.	Remarks
H	POWER TAKE-OFF	MT0193	1	SAE B Flange, 2 or 4 bolt
H1	PTO housing	MT1300	1	
H2	Driven gear	MT1297	1	
H3	Needle bearing	0563003	1	
H4	Driving gear	MT1296	1	
H5	Spacer	MT1295	1	
H6	O ring	0430771	1	
H7	Washer	MT1301	1	
H8	Tab washer	MT1302	1	
H9	Screw	0041008	1	
H10	Spring washer	0191107	3	
H11	Bolt	0041216	1	
H12	Ball bearing	40M433	1	
H13	Adaptor flange	MT1299	1	
H14	Gasket	MT1307	1	4 bolt
H14	Gasket	MT5012	1	2 bolt
H15	Circlip	0250620	1	
H16	Cover plate	MT1293	1	Transit only
H17	Screw	0041208	2	
H18	Gasket	MT1303	1	
H19	Cap screw	0081520	1	
H20	Cap screw	0081685	2	Not illustrated
H21	Circlip	CM2067	1	
H22	Adaptor	CP1255	1	
H23	Oil pipe	MT766	1	
H24	Tee piece	CP1367	1	
H25	Washer	0201715	1	
H26	Metering union	MT4583	1	

09

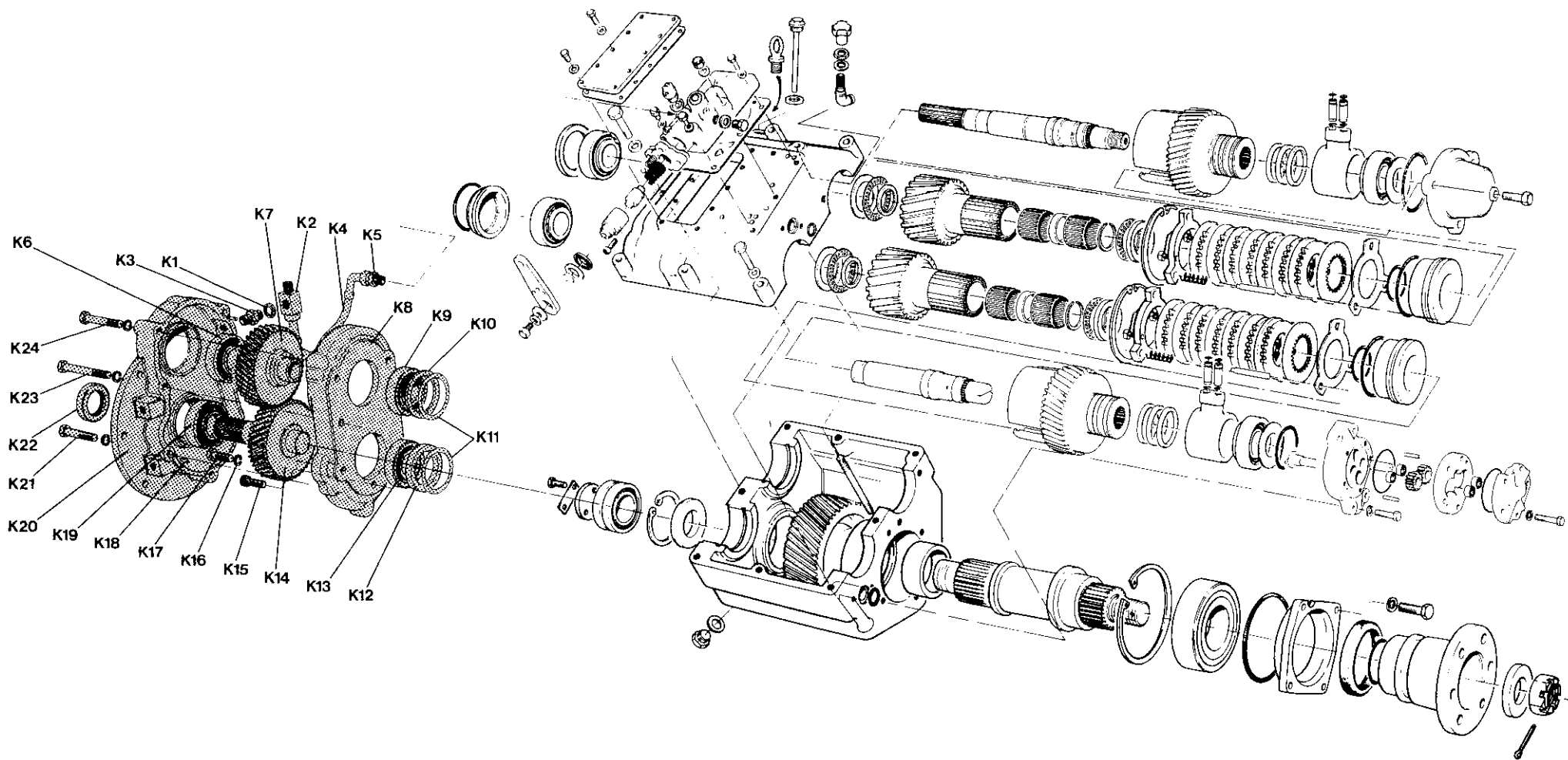

PRM302

Plate Ref.	Description	Part No.	Qty.	Remarks
K	IN-LINE UNIT	MT0279	1	
K1	Dowty Washer	0201715	1	
K2	Tee piece	CP1367	1	
K3	Metering union	MT4583	1	
K4	Oil pipe	MT766	1	
K5	Adaptor	CP1255	1	
K6	Bearing	0540352	1	
K7	Gear	MT1435	1	45T LH
K8	Gearcase	MT1433	1	
K9	Bearing	0450351	1	
K10	Spacer	MT1465	1	
K11	Shim 0.002	MT1077/02		As required
K11	Shim 0.010	MT1077/10		As required
K11	Shim 0.031	MT1077/31		As required
K12	Spacer	MT1440	1	
K13	Bearing	0540301	1	
K14	Gear and shaft	MT1434	1	45T RH
K15	S.H. screw	0081620	1	
K16	Spring washer	0191107	11	
K17	Bolt	0041208	4	
K18	Dowel	0210614	2	
K19	Bearing	0540402	1	
K20	Gear case	MT1432	1	
K21	Bolt	0041217	3	
K22	Oil seal	0400351	1	
K23	Bolt	0041222	2	
K24	Bolt	0041215	2	

