

SERVICE MANUAL

VELVET DRIVE[®]

HYDRAULIC TRANSMISSION

REDUCTION GEAR ASSEMBLY
2.100 : 1 RATIO

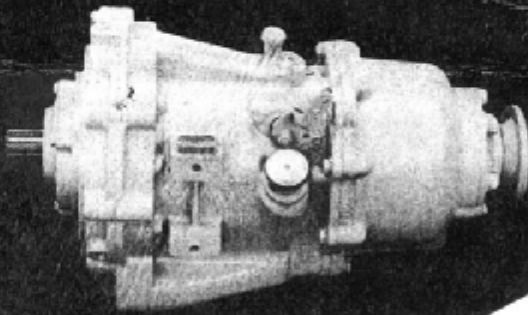

Warner Gear/Warner Motive

DIVISIONS OF BORG-WARNER CORPORATION



GENERAL OFFICES, 1106 EAST SEYMOUR STREET, MUNCIE, INDIANA 47302

PRICE \$1.50

SERVICE MANUAL

"VELVET DRIVE"[®]
HYDRAULIC TRANSMISSION

REDUCTION GEAR ASSEMBLY
2.100 : 1 RATIO

This Service Manual for the 2.10 to 1 Reduction Units is prepared and illustrated for use in conjunction with the present 70C, 71C and 72C Direct Drive Service Manuals, but it also contains supplementary information and illustrations which allow it to be used for servicing of the earlier model transmissions.

Warner Gear/Warner Motive



TABLE OF CONTENTS

| | |
|---|----|
| TRANSMISSION DESCRIPTION | 3 |
| OUTLINE DRAWING OF CURRENT 2.10:1 REDUCTION UNIT | 3 |
| CROSS SECTIONAL VIEW OF AN AS3-71C TRANSMISSION | 4 |
| PARTS LIST FOR FORWARD AND REVERSE SECTION OF TRANSMISSION | 5 |
| 2.10:1 REDUCTION PARTS LIST | 6 |
| OIL CIRCUIT VARIATIONS IN 2.10:1 REDUCTION UNITS. | 7 |
| OUTLINE DRAWINGS SHOWING COOLER RETURN LOCATIONS | 8 |
| PARTS INTERCHANGEABILITY. | 9 |
| DISASSEMBLY OF TRANSMISSION | 10 |
| INSPECTION AND GENERAL INSTRUCTIONS. | 10 |
| ASSEMBLY OF TRANSMISSION. | 11 |
| ASSEMBLY OF THE 2.10:1 REDUCTION UNIT | 12 |
| TRANSMISSION INSTALLATION DIMENSIONS | 13 |
| TRANSMISSION INSTALLATION | 14 |
| LIST OF CURRENT PRODUCTION 2.10:1 REDUCTION UNITS | 14 |
| HYDRAULIC FLUID RECOMMENDATIONS. | 14 |
| DRAWINGS OF PLANETARY ASSEMBLIES. | 15 |
| 2.10:1 REDUCTION PLANETARY SERVICE KITS. | 16 |
| TORQUE SPECIFICATIONS. | 16 |

TRANSMISSION DESCRIPTION

The 2.10:1 reduction gear box operates in conjunction with any one of the following Velvet Drive® models: 70, 70R, 70C, 70CR, 71, 71R, 71C, 71CR, 72, 72R, 72C and 72CR. Reduction is accomplished by a planetary gear set, which reduces the input revolutions by a fixed 2.10:1 speed ratio in both forward or reverse. The 72, 72R, 72C and 72CR forward and reverse transmissions have a 1.1:1 ratio of reduction when operated in reverse and therefore the overall reduction of these models when reverse is selected is 2.31:1.

The direction of rotation of the splined output shaft and coupling of the reduction gear box, when operated in forward is the same as engine rotation and is coaxial with the input shaft of the forward and reverse transmission.

The 2.10 reduction unit is identical for all 70C, 71C or 72C units; however, all 70CR, 71CR and 72CR units use a different reduction planetary gear and cage assembly. These two planetary gear and cage assemblies must not be used in units which have opposite rotation. The oil pump on 2.10 reduction units can not be indexed for opposite input rotation unless the reduction planetary gears and cage assembly is also changed.

Model numbers will end in either C or CR. The C designates transmissions which have been assembled for clockwise rotation. The CR designates transmissions which have been assembled for counter-clockwise rotation. The R will be hand stamped on CR units.

The hand of rotation as used to describe all Velvet Drive transmissions, refers to the direction of rotation of transmission input shaft as viewed when standing behind the coupling end of the transmission and facing towards front of transmission.

The pump hand of rotation is described when standing at the input end of the transmission and facing the pump. The pump designation is opposite to the designation given for transmission rotation because the pump is viewed from the opposite end of the transmission.

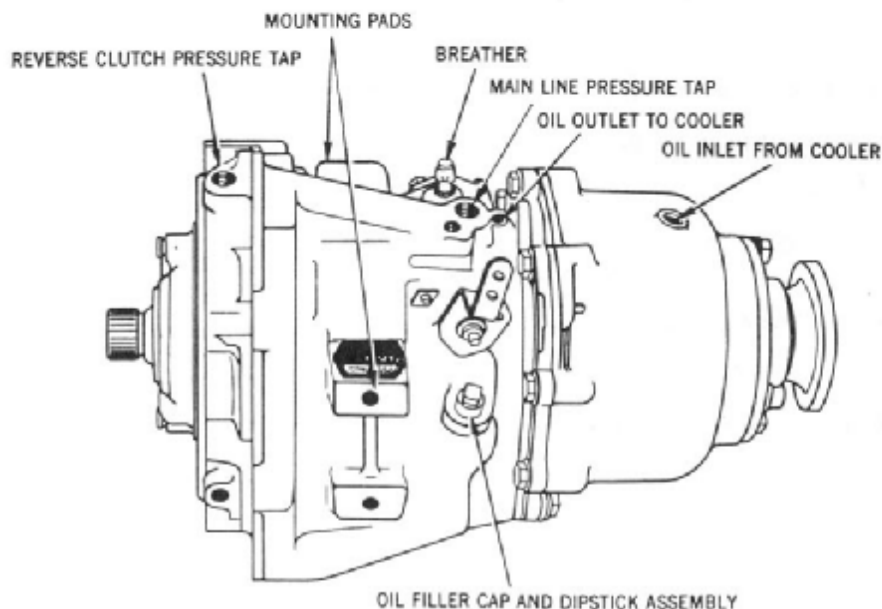

FIG. 1 OUTLINE DRAWING OF A CURRENT 2.10:1 REDUCTION UNIT.

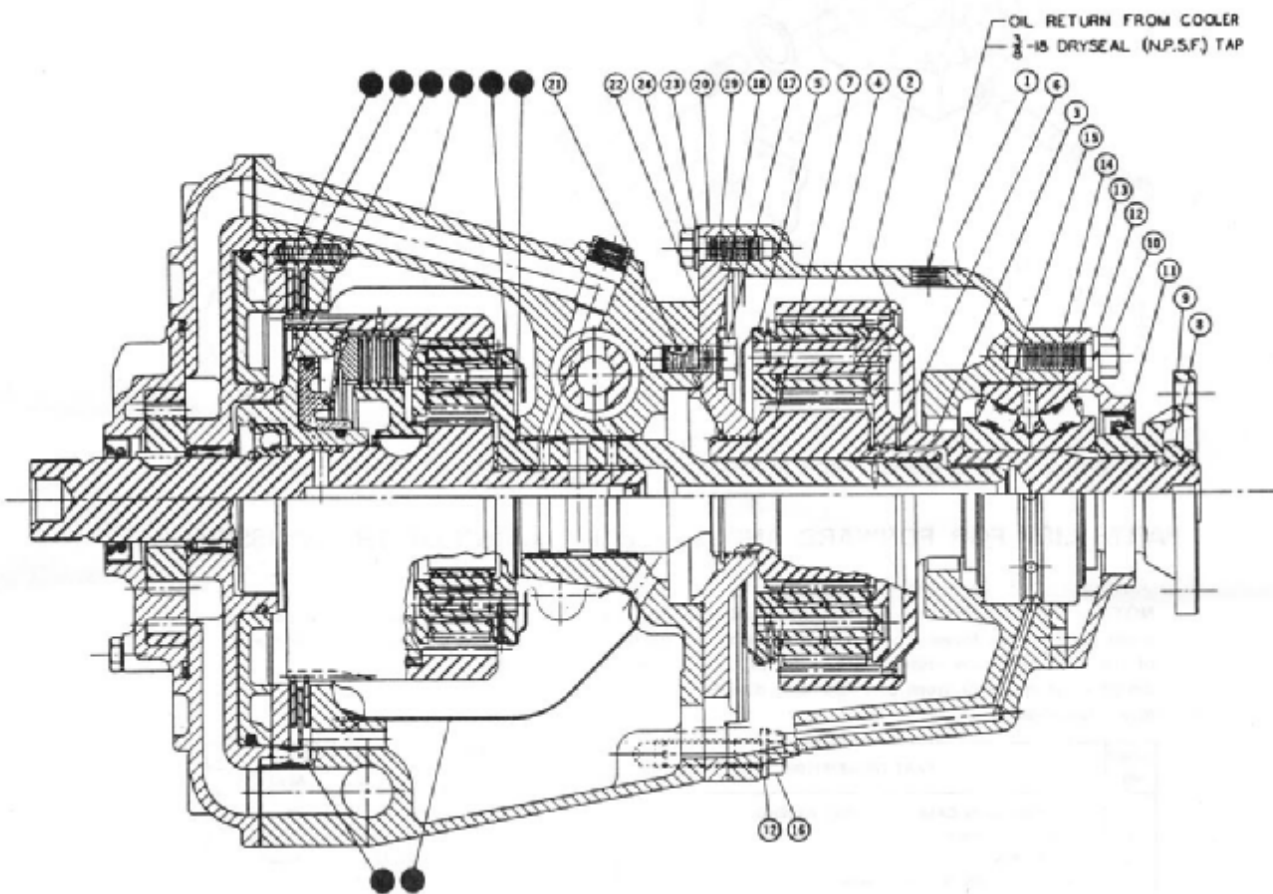

FIG. 2 CROSS SECTIONAL VIEW OF AN AS3-71C TRANSMISSION

This cross sectional view has the reduction unit parts numbered to correspond to index numbers used in the reduction unit parts list. Parts of the forward and reverse transmission which are pointed out and are not numbered are different or differ in the number required in reduction units from similar direct drive units. The AS3-70C and AS13-72C transmissions are similar to the AS3-71C transmission except for minor differences, which can be noted from parts lists.

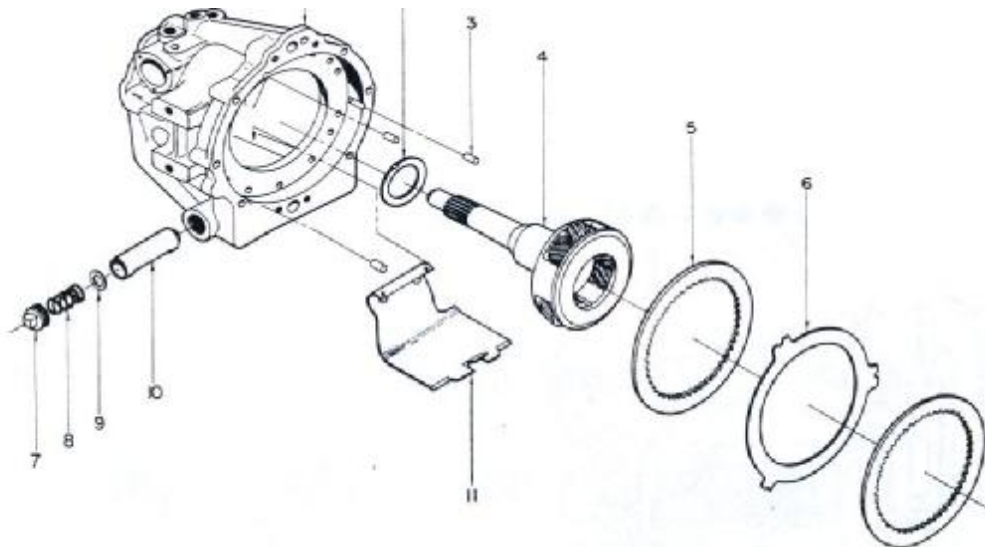

FIG. 3 PARTS DISPLAY FOR FORWARD & REVERSE SECTION OF TRANSMISSION

PARTS LIST FOR FORWARD AND REVERSE SECTION OF TRANSMISSION

NOTE: The following parts list identifies only those parts of the forward and reverse section of the 2.10 reduction units, which differ in design or in quantity from corresponding direct drive transmission.

Use the appropriate direct drive manual parts list to identify parts not listed below. Index numbers refer to Fig. 3.

| INDEX NO. | PART DESCRIPTION | NO. REQ'D | PART NUMBER VS MODEL | | |
|-----------|---|-----------|----------------------|------------|------------|
| | | | AS3-70C | AS3-71C | AS13-72C |
| 1 | TRANSMISSION CASE & BUSHING ASSEMBLY | 1 | 71-A1L | 71-A1K | 72-A1K |
| 2 | THRUST WASHER | 1 | 71-159 | 71-159 | 71-159 |
| 3 | DOWEL PIN | 3 | | R6-177 | 4122E |
| | DOWEL PIN (25/32" Deep Cavity) | 3 | 71-87 (1) | 71-87 (1) | |
| | DOWEL PIN (41/64" Deep Cavity) | 3 | 71-87A | | |
| 4 | PINION CAGE & OUTPUT SHAFT ASSEMBLY | 1 | 71-1A2B | 71-1A2B | 72-1A2B |
| 5 | REVERSE CLUTCH PLATE (25/32" Deep Cavity) | 1 | 71-86 (1) | 71-86 (1) | |
| | REVERSE CLUTCH PLATE (29/32" Deep Cavity) | 3 | | | 72-A66 (1) |
| | REVERSE CLUTCH PLATE (55/64" Deep Cavity) | 2 | | 72-A66B | |
| | REVERSE CLUTCH PLATE (1-5/64" Deep Cavity) | 3 | | | 72-A66B |
| | REVERSE CLUTCH PLATE (41/64" Deep Cavity) | 1 | 72-A66B | | |
| 6 | OUTER REVERSE CLUTCH PLATE | 1 | | 72-176 | |
| | OUTER REVERSE CLUTCH PLATE | 2 | | | 72-176 |
| 7 | 3/4" PIPE PLUG | 1 | 0000444592 | 0000444592 | 0000444592 |
| 8 | SPRING | 1 | 5L-222 | 5L-222 | 5L-222 |
| 9 | WASHER | 1 | 35-143 | 35-143 | 35-143 |
| 10 | OIL INLET SHIELD | 1 | 72C-98 | 72C-98 | 72C-98 |
| 11 | OIL BAFFLE | 1 | 71-140 | 71-140 | 71-140 |
| | OIL STRAINER (2) - Use for all replacements | 1 | 71C-A98A | 71C-A98A | 71C-A98A |
| | DRAIN PLUG (3) - Used with Annular Gasket | 1 | 453006 | 453006 | 453006 |
| | ANNULAR GASKET (2) | 1 | 120428 | 120428 | 120428 |
| | SELECTIVE THRUST WASHER | 1 | 71-158 | 71-158 | 71-158 |
| | SELECTIVE THRUST WASHER | | 71-15C | 71-15C | 71-15C |

(1) NOT CURRENT PRODUCTION - available for repairing earlier units.
 (2) SEE FIG. 7.

(3) SEE FIG. 8 - ALSO NOTE (1).

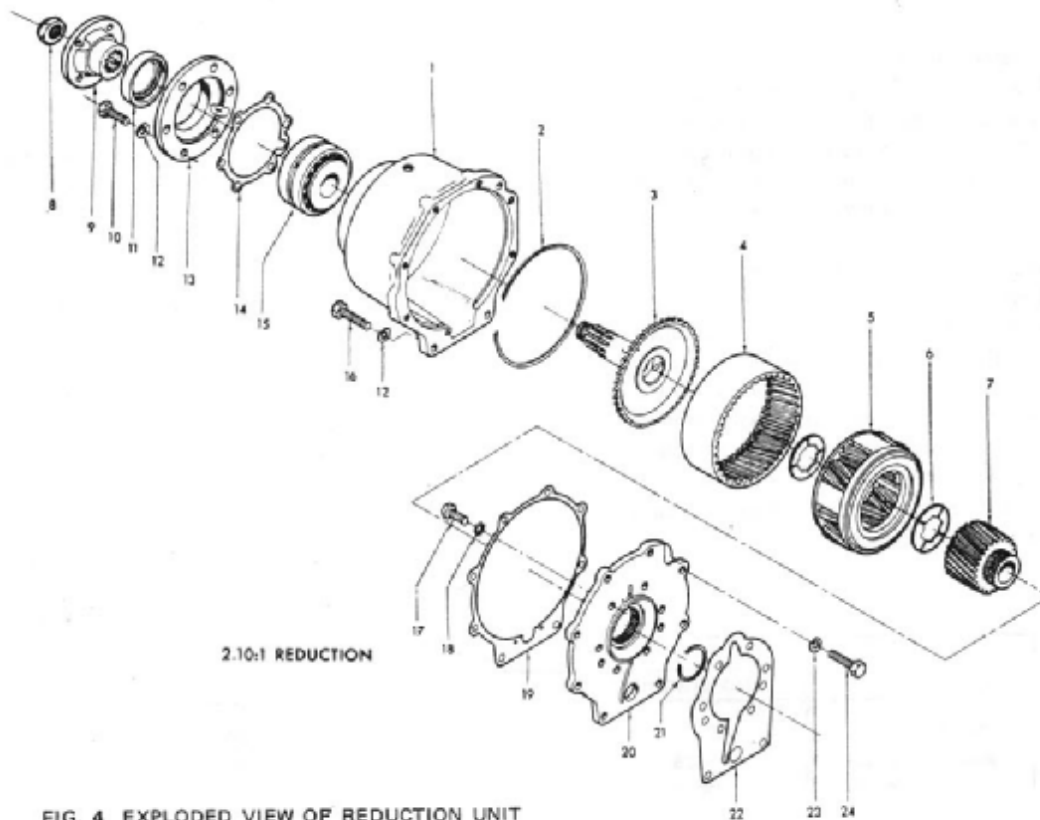

FIG. 4 EXPLODED VIEW OF REDUCTION UNIT

2.10:1 REDUCTION PARTS LIST

| INDEX NO. | PART NO. | PART DESCRIPTION | NO. REQ'D. |
|-----------|------------|--|------------|
| 1 | L5-1B | REDUCTION HOUSING - CURRENT | 1 |
| | L5-1 | REDUCTION HOUSING - EARLIEST | |
| 2 | 4756D | SNAP RING - (Ring Gear) | 1 |
| 3 | L5-A2 | REDUCTION UNIT MAINSHAFT & BUSHING ASSEMBLY | 1 |
| 4 | L3-6 | RING GEAR | 1 |
| 5 | L5-1A150 | PLANETARY GEARS & CAGE ASSEMBLY (for CR units) | 1 |
| | L5A-1A150 | PLANETARY GEARS & CAGE ASSEMBLY (for C units) | |
| 6 | L3-24 | THRUST WASHER | 2 |
| 7 | L5-4 | SUN GEAR | 1 |
| 8 | 4775L | MAINSHAFT NUT | 1 |
| 9 | 4547BA | COUPLING (for Models 70C & 71C) | 1 |
| | 4547AY | COUPLING (for Model 72C) | |
| 10 | 0000179850 | 7/16"-14x1-1/4" HEX HEAD BOLT | 6 |
| 11 | 71C-110 | OIL SEAL | 1 |
| 12 | 0000103322 | 7/16" LOCK WASHER | 8 |
| 13 | L4-7 | BEARING RETAINER | 1 |
| 14 | L4-147 | BEARING RETAINER GASKET | 1 |
| 15 | 4820A | BEARING (was X3372) | 1 |
| 16 | 0000179864 | 7/16"-14x1-3/4" HEX HEAD BOLT | 2 |
| 17 | 4853D | 7/16"-14x1" LOCK BOLT | 6 |
| 18 | 0000114607 | 7/16" LOCK WASHER | 6 |
| 19 | L4-145 | ADAPTER GASKET - REAR | 1 |
| 20 | L5-8A | REDUCTION UNIT ADAPTER - CURRENT | 1 |
| | L5-8 | REDUCTION UNIT ADAPTER - EARLIEST | |
| 21 | 4786A | SNAP RING (Sun Gear) | 1 |
| 22 | L4-145 | ADAPTER GASKET - FRONT | 1 |
| 23 | 0000103321 | 3/8" LOCK WASHER | 8 |
| 24 | 0000179840 | 3/8"-16x1-1/8" HEX HEAD BOLT | 8 |

OIL CIRCUIT VARIATIONS IN 2.10:1 REDUCTION UNITS

Four circulation systems have been used for cooler and lubrication oil flow to the reduction gear set and rear bearing of 2.10 reduction transmissions. Units which have the earliest circulation system have the cooler oil returned to a tapped hole which is located on the lower right side of the reduction housing, (Fig. 6).

Transmissions which have cooler oil returned through a bushing in the drain plug opening of the forward and reverse transmission (as illustrated in Fig. 7) will either have the second or third circulation system. Units which have the second system have a crooked track on the reduction adapter front face. Units which have the third system have two short straight tracks on the reduction adapter front face, (Fig. 5, Item C). A visual inspection of the adapter front face will be required to determine which of these two systems is being used.

Any 2.10 reduction transmission with a serial number prior to those listed for the third system, which has been rebuilt to the third circulation system at our factory, has the letter Z hand-stamped in the lower right-hand corner of the name plate opposite the name Warner Gear Division.

Transmissions which have the fourth system have cooler oil returned to the top of the reduction housing (as shown by Fig. 6). Oil screen (71-A98A), tube (71C-84), bushing (4885B), and dipstick (71-A195) were removed and pump inlet shield (72C-98), washer (35-143), spring (5L-222), a 3/8" pipe plug (000444592) were added to transmissions which have the fourth system, (Fig. 6).

| MODEL | EFFECTIVE SERIAL NUMBER | | |
|--------------|-------------------------|-------------|-------------|
| | 2ND CIRCUIT | 3RD CIRCUIT | 4TH CIRCUIT |
| AS3-70C & CR | 1564 | 2326 | 2920 |
| AS3-71C & CR | 4328 | 6423 | 8483 |
| AS3-72C & CR | 3530 | 5459 | 6444 |

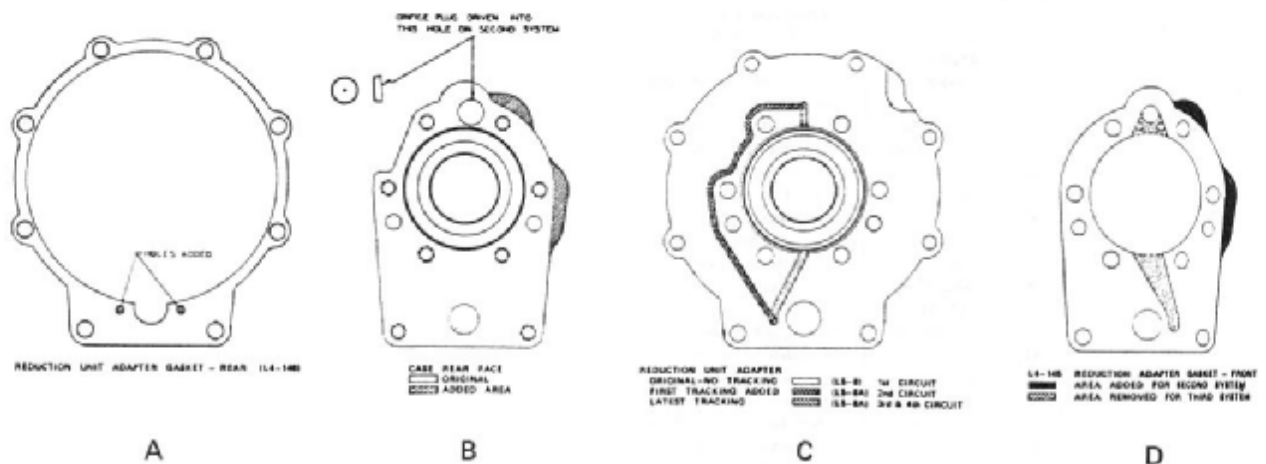

FIG. 5 PARTS REQUIRED FOR THE VARIOUS CIRCULATION SYSTEMS

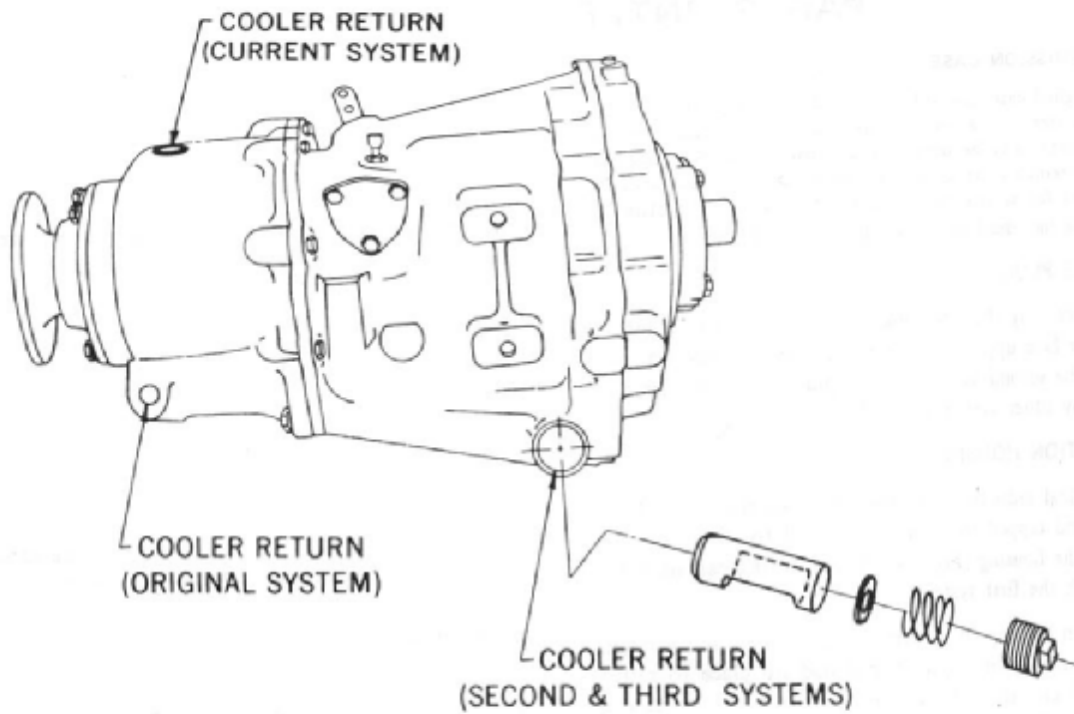

FIG. 6 VARIOUS COOLER RETURN LOCATIONS WITH PARTS USED WITH FOURTH SYSTEM SHOWN.

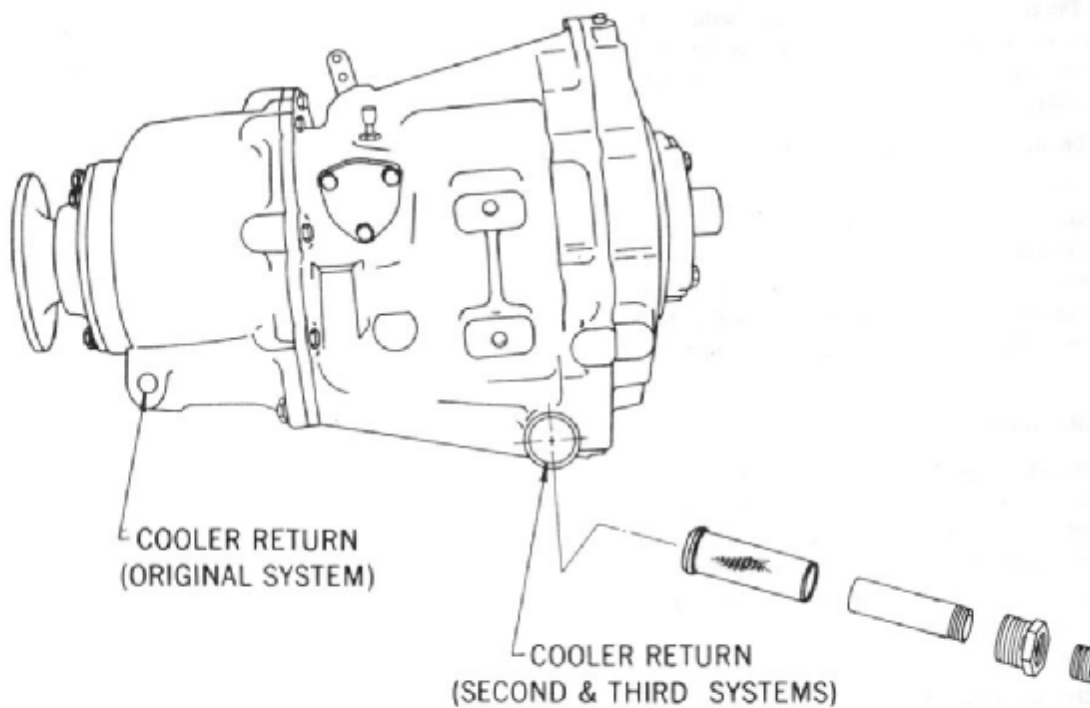

FIG. 7 VARIOUS COOLER RETURN LOCATIONS WITH PARTS USED WITH SECOND & THIRD SYSTEMS SHOWN.

PARTS INTERCHANGEABILITY

TRANSMISSION CASE

The original case can only be used with the first oil circulation system. The revised case, first used with the second system, may be used for all four systems. The part number remains the same and only revised cases will be furnished for service parts. The revised case has the rear face area increased as shown in Fig. 5, Item B.

ORIFICE PLUG

An orifice plug (Part Number 4572X) was driven into the case rear face upper hole (Fig. 5, Item B) only on units having the second system. This plug should be omitted when any other system is used.

REDUCTION HOUSING

The original reduction housing (Part Number L5-1) was drilled and tapped to return cooler oil to the lower right side of the housing (Fig. 6). This housing can only be used with the first system.

Reduction housing (Part Number L5-1A) was used with the second and third system and had no place to return cooler oil into the reduction housing. This housing can only be used with units having either the second or third system.

Reduction housing (Part Number L5-1B) is drilled and tapped to return cooler oil to the top of the housing (Fig. 6). The correct housing must be used with each system; however, all three earlier systems may be updated to the latest system by including the proper parts in the assembly.

REDUCTION ADAPTER GASKET - REAR

Two small holes (Fig. 5, Item A) were added to reduction adapter gasket - rear (L4-146) for use with the second circulation system. This gasket with the two small holes may be used for all replacements. The gaskets without the two small holes should no longer be available, but should never be used except with the first circulation system.

REDUCTION ADAPTER GASKET - FRONT

The reduction adapter gasket - front (L4-145) was changed twice by first adding material to cover the crooked track in adapter front face and later the gasket was cut out to match the straight track used with the third system (Fig. 5, Item D). The latest gasket may be used for all four systems and will be the only gasket supplied for service.

REDUCTION UNIT ADAPTER

The original adapter (L5-8) was used with the first sys-

tem and did not have a track on its front face. This adapter cannot be used with other systems.

The second adapter (L5-8A) was used with the second system and has a curved track on its front face. This adapter should be replaced with the (L5-8B) adapter.

The adapter used with the third and fourth system (L5-8B) has two short straight tracks connected by an undercut on the case face.

Only the latest adapter (L5-8B) will be furnished for service parts; however, it may be possible to obtain the earliest adapter until the current supply is depleted.

The oil strainer, annular gasket, and drain plug, illustrated in (Fig. 8), can only be used with cases having the case face machined to seal on the annular gasket.

Parts illustrated in (Fig. 7) are used with the second and third circulation systems. The oil strainer with an open end is also used as a service replacement part to replace the strainer illustrated in (Fig. 8) for use with the first circulation system.

The pipe plug illustrated in (Fig. 7) replaced the annular gasket and drain plug. Case threads are different for each plug, therefore these plugs are not interchangeable.

Parts used with the third circulation system which are omitted when changing to the fourth system are shown in (Fig. 7). Parts used in the fourth system are shown in (Fig. 6). Individual parts are not interchangeable. These parts may be changed if all parts of each group are used together.

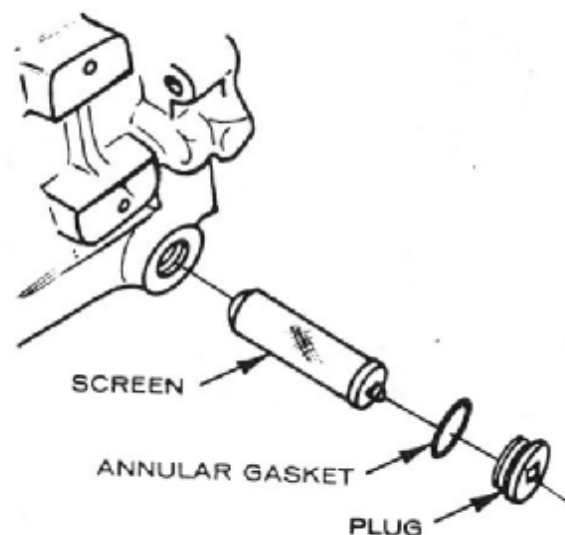

FIG. 8 EARLY SCREEN & DRAIN PLUG

DISASSEMBLY OF TRANSMISSION

REMOVAL OF REDUCTION HOUSING, RING GEAR AND MAIN SHAFT ASSEMBLY

1. Place transmission right side up on a clean bench and loosen the main shaft nut.
2. Place an inch thick block under the rear of forward and reverse transmission just forward of reduction unit adapter so that reduction unit will clear bench.
3. Remove the two 7/16 bolts and lockwashers which fasten the reduction housing and the reduction adapter to the forward and reverse transmission case, and the 3/8 bolts which fasten the reduction adapter to the reduction housing. Slide the reduction housing, ring gear and main shaft assembly rearward off the transmission.

REMOVAL OF PINION CAGE ASSEMBLY

4. Remove thrust washer from rear of planet cage.
5. Slide planet cage assembly rearward from unit.
6. Remove thrust washer from rear of sun gear.

REMOVAL OF REDUCTION UNIT ADAPTER AND SUN GEAR ASSEMBLY

7. Remove six lock bolts and lockwashers that retain reduction unit adapter, then remove adapter and sun gear assembly from forward and reverse transmission.

8. Remove snap ring from sun gear, then remove sun gear from reduction unit adapter.

DISASSEMBLY OF RING GEAR, MAIN SHAFT, COUPLING AND BEARING FROM REDUCTION HOUSING

9. Remove main shaft nut and coupling, then slide ring gear and main shaft from reduction housing.
10. Remove snap ring and main shaft from ring gear.
11. Remove bearing retainer after removing six hex head bolts and lockwashers that retain it.
12. Lift rear bearing cone from its cup.
13. The outer race and front cone can be pressed from reduction housing on an arbor press. Press on rear face of front bearing cone while reduction housing is supported on its rear face on a clean flat surface.

DISASSEMBLY OF FORWARD & REVERSE TRANSMISSION

14. Follow disassembly procedures given in Service Manual, Velvet Drive® Hydraulic Transmission either Model 70C & 71C, or 72C as required for disassembly of forward and reverse transmission.

INSPECTION AND GENERAL INSTRUCTIONS

1. Cleanliness is absolutely necessary during assembly to insure proper functioning of transmission. Transmission case passages should always have plugs removed to allow for thorough cleaning. Use compressed air, when available, to dry parts before they are assembled. Do not wipe parts with rags to clean or dry them as lint from the cloth may cause erratic valve action.
2. Inspect all parts for damage or wear. Replace defective parts.
3. Gaskets, oil seals and rubber parts should be replaced, except in new units. Exercise judgement as to the need for replacing these parts.
4. Oil seals and bearings are best installed by using an arbor press, suitable fixtures, and tools to properly align parts being assembled. Hammering seals and bearings into position can severely damage parts.
5. Automatic transmission fluid should be used to lubricate parts as they are assembled. Petroleum jelly may be used on gaskets or other parts that must be held in position during assembly. Lubricated parts will assemble more freely than dry parts.
6. Tighten all bolts and screws evenly to the recommended torque.

ASSEMBLY OF TRANSMISSION

ASSEMBLE FORWARD & REVERSE SECTION

1. Place the reduction housing on its forward face, and then set the transmission case so that its rear face is supported on the rear face of the reduction housing. This will provide proper support for the transmission case during the assembly of the forward and reverse unit when the pinion cage and output shaft assembly protrudes from the rear of the case.
2. Coat steel back of thrust washer with petroleum jelly. Install thrust washer on inside thrust surface of case with washer tang positioned in case groove as shown in (Fig. 9).
3. Install pinion cage and output shaft flush against thrust washer. Avoid rotation of pinion cage and output shaft during assembly as it tends to unseat washer tang from its groove.

NOTE: Pinion cage and output shaft assemblies (71-1A2B) and (72-1A2B) have been supplied

with three oil grooves and without oil grooves as shown in (Fig. 10). The grooved shafts may be used in transmission cases having bronze bushings and in transmission cases without bronze bushings. The ungrooved shafts may be used only in transmission cases which have bushings installed.

4. Complete forward and reverse transmission assembly by following instructions given in either the Service Manual for 70C & 71C, or 72C Velvet Drive® Hydraulic Transmission as required.

NOTE: The oil inlet shield should not be removed from the forward and reverse transmission case; however, if removed or when a new case is used, the shield should be pressed into position with the opening located down in the transmission as shown in (Fig. 6).

5. Check end play, which should be from .004 - .043. The (71-15B) or (71-15C) thrust washers may be changed to correct end play.

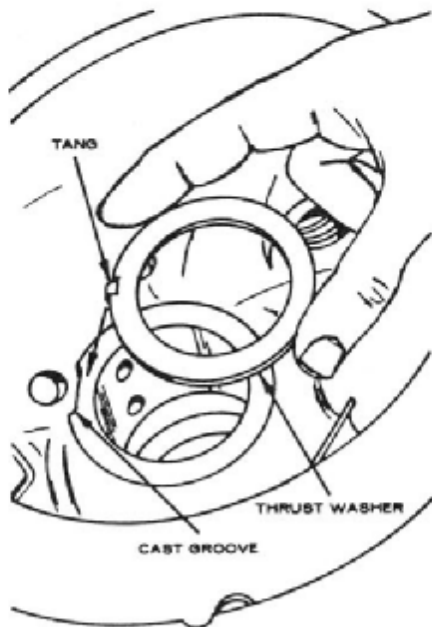

FIG. 9 THRUST WASHER USED FOR 2.10 REDUCTION UNIT

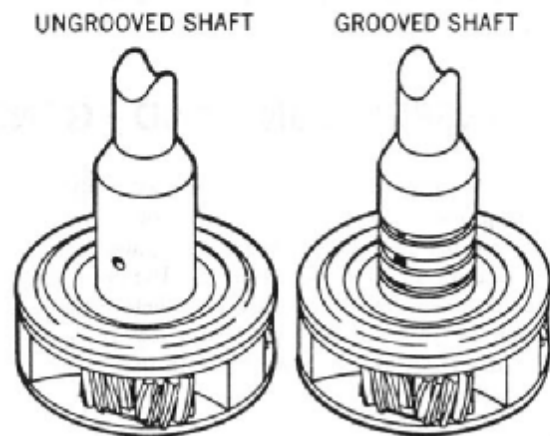

FIG. 10 OUTPUT SHAFT VARIATIONS

ASSEMBLY OF THE 2.10:1 REDUCTION UNIT

NOTE: The number following each part name is the index number of the part in the exploded view, (Fig. 4).

1. Slide the sun gear (7) splines into the reduction unit adapter (20) splines until the gear bottoms on the adapter shoulder.
 2. Support the adapter and sun gear on the sun gear rear face and install a snap ring (21) in the sun gear groove.
 3. Assemble the adapter front gasket (22) and the adapter with sun gear to the forward and reverse transmission rear face.
 4. The two 7/16-14 x 1-3/4 hex head bolts (16) should be started in the case threads to insure adapter alignment.
 5. Assemble six NEW 7/16-14 x 1 nylock bolts (17) and external tooth lockwashers (18) to retain the adapter. Remove the two 7/16 bolts, which were installed in step four after the nylock bolts have been properly torqued.
 6. Install a thrust washer (6) on the sun gear rear face.
- CAUTION:** Two different planetary cage assemblies are used in 2.10:1 reduction units. Two 1/4 inch dimples on the rear face of the L5A-1A150 identifies this assembly, which must only be used in C units. The L5-1A150 used in CR units has no identification marks. See instruction sheets Fig. 12 and 13 on page 15
7. Rotate the proper planetary cage and gear assembly (5) to engage pinion gear teeth with sun gear teeth as the planetary assembly is assembled against the thrust washer on sun gear rear face.
 8. Assemble a thrust washer on pinion cage against rear thrust face.
 9. Assemble the mainshaft (3) and a snap ring (2) into the ring gear (4).
 10. Rotate the ring gear to align gear teeth as the ring gear and mainshaft are assembled over the planetary gears.
 11. Place the reduction housing (1) front face on a

clean flat surface under an arbor press. Place one of the tapered roller bearings (15) on the shoulder in reduction housing bore.

NOTE: Bearings are received in matched sets and match marks must check. The outer race and one tapered roller bearing will have the same number with an "A" suffix. The other tapered roller bearing will have the same number without the "A" suffix. The parts having the "A" suffix should be placed together and the tapered roller bearing without the suffix should be placed in the end of the outer race which is not numbered.

12. The outer race should be lubricated and pressed into the reduction housing and should bottom in housing bore.
13. Place the rear set of tapered rollers in the outer race.
14. Place the bearing retainer gasket (14) on the reduction housing rear face, aligning the gasket slot with the housing oil hole.
15. Apply a suitable sealant to the oil seal outside diameter and press a new seal (11) into the bearing retainer (13). Caution should be observed to insure that too much sealant is not used. The oil seal rear face should be flush with retainer rear face when assembled.
16. Assemble the bearing retainer to the reduction housing, aligning oil holes and bolt holes of these parts with those of the gasket. Six 7/16-14 x 1-1/4 hex head bolts (10) and lock washers (12) retain these parts.
17. Use petrolatum to hold reduction adapter rear gasket (19) in position and assemble the reduction housing and bearing assembly over the output shaft and into position against the adapter rear face. Six 3/8-16 x 1-1/8 hex head bolts (24) and lockwashers (23), two 7/16-14 x 1 3/4 hex head bolts (16) and lockwashers (12) retain these parts.
18. Inspect the coupling for burrs and sharp edges, which might damage the seal or prevent proper sealing. Assemble the coupling over the mainshaft splines and replace the mainshaft nut. A sealant such as permatex should be used under the mainshaft nut and on shaft splines to prevent oil from leaking past the splines.

TRANSMISSION INSTALLATION

An oil cooler must be properly connected into the cooler circuit of all Velvet Drive® Transmissions; otherwise high pressure will cause transmission damage. Three different cooler return locations have been used on the various 2.10 reduction units. Connect the cooler return line to the lower right side of the reduction housing if a drilled and tapped hole is found at this location, connect to top of reduction housing if a drilled and tapped hole is found at this location, or on units which do not

have the reduction housing tapped in either of these locations, return cooler oil to the forward and reverse transmission sump bushing.

It is wise to check the pump setting, which should agree with engine rotation. The chart below gives pump setting for the various 2.10 reduction units.

CAUTION: DO NOT CHANGE PUMP SETTING.

CURRENT PRODUCTION 2.10:1 REDUCTION UNITS

| ASSEMBLY NUMBER | ROTATION | | | PUMP SETTING | APPROX. WEIGHT | SPEED RATIO | |
|-----------------|----------|-------|-----|--------------|----------------|-------------|------|
| | IN | OUT | | | | FOR'D | REV |
| | | FOR'D | REV | | | | |
| AS3-70C | C | C | CC | L. H. | 143 | 2.10 | 2.10 |
| AS3-70CR | CC | CC | C | R. H. | 143 | 2.10 | 2.10 |
| AS3-71C | C | C | CC | L. H. | 145 | 2.10 | 2.10 |
| AS3-71CR | CC | CC | C | R. H. | 145 | 2.10 | 2.10 |
| AS13-72C | C | C | CC | L. H. | 153 | 2.10 | 2.31 |
| AS13-72CR | CC | CC | C | R. H. | 153 | 2.10 | 2.31 |

It is recommended that all installations using a reduction gear have a suitable locking device or brake to prevent rotation of the propeller shaft when the boat is not under direct propulsion. If the marine gear is not in operation and the forward motion of the boat causes the propeller shaft to rotate, lubricating oil will not be circulated through the gear because the oil pump is not in oper-

ation. Overheating and damage to the marine gear may result unless rotation of the propeller shaft is prevented.

For other important information refer to sections, "Installation Precautions", and "Transmission Operation", of the appropriate 70C & 71C, or 72C direct drive manuals.

HYDRAULIC FLUID RECOMMENDATIONS

Either Type "A", Suffix "A", or Dexron automatic transmission fluids are recommended for use in Velvet Drive® Transmissions. Good quality engine oil may be used in applications where the maximum input speed does not exceed 3000 RPM.

The transmission, cooler and cooler lines must be filled and the complete hydraulic system must be purged of air prior to making the final oil level check. A properly installed cooler will be self-purging. The transmission should be filled before the engine is started. An assistant should be on hand to add oil as soon as the engine has started so that oil which is pumped into the cooler and cooler lines will be replaced before the oil suction inlet becomes exposed to air. Air which is pumped into the hydraulic system will cause foaming and a false oil level reading.

A transmission which has not been completely filled with oil will operate; however, there will be no cooler flow and the unit will overheat.

For other important information pertaining to filling of the transmission with oil, checking oil level, or changing transmission oil, refer to section "Lubrication Recommendations", of the appropriate 70C & 71C, or 72C direct drive manuals.

TRANSMISSION OIL CAPACITY (QUARTS)

This chart gives the oil capacity for the transmission only and does not include capacity of cooler and cooler lines.

| MODEL | 15° INCLINED | LEVEL |
|---------------|--------------|-------|
| AS3-70C & CR | 2.7 | 2.5 |
| AS3-71C & CR | 2.7 | 2.5 |
| AS13-72C & CR | 2.8 | 2.7 |

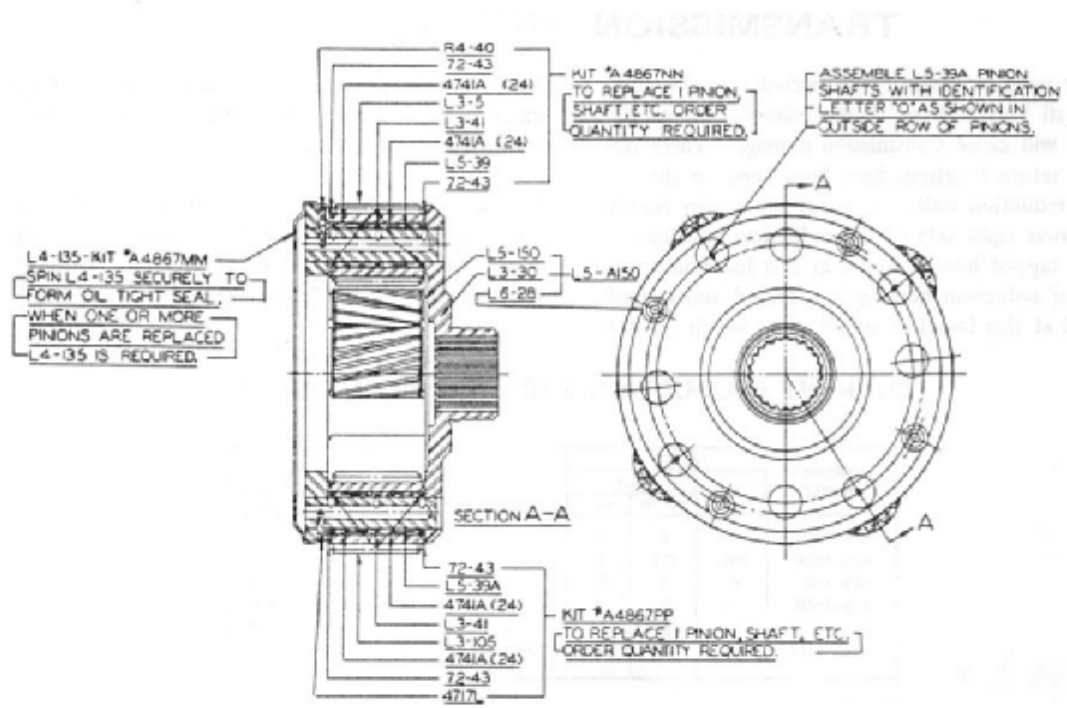

FIG. 12 L5-1A150 PLANETARY ASSEMBLY USED IN CR UNITS.

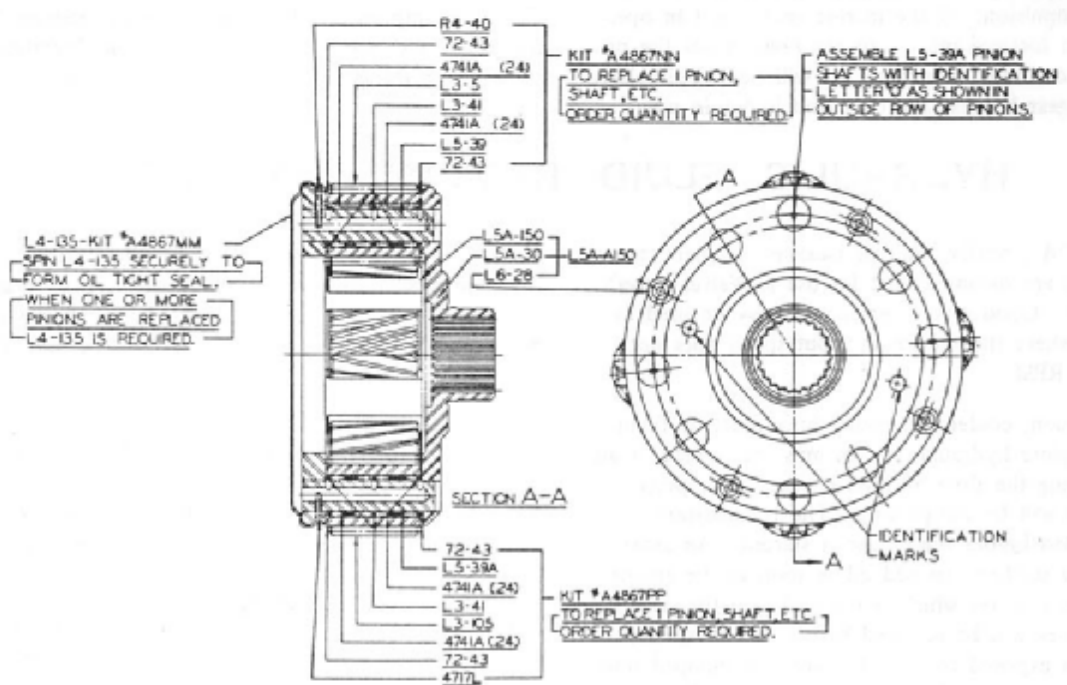

FIG. 13 L5A-1A150 PLANETARY ASSEMBLY USED IN C UNITS.

2.10:1 REDUCTION PLANETARY SERVICE KITS

Kit Number A4867NN contains all parts required to replace one inner pinion in either of the two cage assemblies.

Kit Number A4867PP contains all parts required to replace one outer pinion in either of the two gear and cage assemblies.

Early pinion kits A4867NN and A4867PP contained one pinion bearing spacer (L3-41) and two thrust washers (L3-43). Current kits should contain three pinion bearing spacers (L3-41) with the additional spacers being placed one at each end of the rows of needles. Current kits will have the two thrust plates (72-43). The thrust plates supplied with each pinion will be used for two adjoining pinions and when two adjoining pinions are both replaced, there will be two extra thrust plates, which will not be needed.

Kit Number A4867MM contains the oil collector ring and

instruction sheets for the various gear and cage assemblies, which this ring is used on. This kit must be ordered any time one or more pinions are to be repaired.

These repair kits make possible the replacement of individual pinions and related parts of the reduction planetary gear sets and eliminates replacing the entire planetary assembly. Only qualified personnel should attempt servicing of planetary gear sets.

NOTE: When disassembling the individual gear sets, the pinion shaft pin, which retains the pinion shaft, should be removed intact after the removal of the oil collector ring. The pinion shaft should not be removed by pounding on the end of the shaft to break the retaining pin, as this distorts the immediate area of the pinion carrier and will produce a damaged thrust surface and improper pinion end clearance when the planetary is reassembled.

TORQUE SPECIFICATIONS

| PART NUMBER | DESCRIPTION | APPLICATION | TORQUE LBS. FT. |
|-------------|---------------------------------------|---|-----------------|
| 179840 | 3/8-16 x 1-1/8 HEX HEAD BOLT | REDUCTION ADAPTER TO REDUCTION HOUSING | 27-32 |
| 179860 | 7/16-14 x 1-1/4 HEX HEAD BOLT | BEARING RETAINER TO REDUCTION HOUSING | 42-50 |
| 179864 | 7/16-14 x 1-3/4 HEX HEAD BOLT | REDUCTION HOUSING AND ADAPTER TO CASE | 42-50 |
| 4853D | 7/16-14 x 1 HEX HEAD BOLT, LOCKING | REDUCTION ADAPTER TO CASE | 42-50 |
| 4775L | 1-20 NUT | OUTPUT SHAFT NUT | 100-200 |

Warner Gear/Warner-Motive

GENERAL OFFICES, 1106 EAST SEYMOUR STREET, MUNCIE, INDIANA 47302, TELEPHONE: 317/284-8411



MARINE TRANSMISSION STANDARD WARRANTY TO ENGINE MANUFACTURERS

Seller guarantees its products against defective material or workmanship for a period of 12 months or 400 hours whichever occurs first from date of delivery to the first owner-operator. Seller's obligation under this guarantee is limited to replacement or repair of any defective material when returned f.o.b. Seller's factory at Muncie, Indiana and shall be subject to Seller's inspection and verification of claim.

Purchasers of engines or boats using our products should follow the procedure designated in the warranty policy supplied by the company from whom the product was purchased.

WARNER GEAR/WARNER-MOTIVE
Divisions of Borg-Warner Corporation
Muncie, Indiana

FORM 108A